

To: Manufacturer's Representatives and Distributors, Contract Service Centers, Sales Team, Internal Support Departments, Operations Team

From: Mark W. Hughes, U.S. National Service Manager

Laars Heating Systems Company is changing the published Service Clearances for Rheos and Rheos+ products. The Service Clearances will now be as follows:

APPLIANCE SURFACE	SERVICE ACCESS CLEARANCE
Piping Side	24" 61cm
Opposite Side	24" 61cm
Top	24" 61cm
Back	36" 91cm
Front	36" 91cm
Vent	Per UL1738

The Rheos and Rheos+ Clearances to Combustibles will remain the same:

APPLIANCE SURFACE	CLEARANCE FROM COMBUSTIBLE MATERIAL
Piping Side	1" 2.5 cm
Opposite Side	1" 2.5 cm
Top	1" 2.5 cm
Back	1" 2.5 cm
Front	1" 2.5 cm
Vent	Per UL1738

All Rheos and Rheos+ literature will be revised to reflect these changes.

If you have any questions regarding this bulletin please call Technical Service at 800.900.9276 x686.

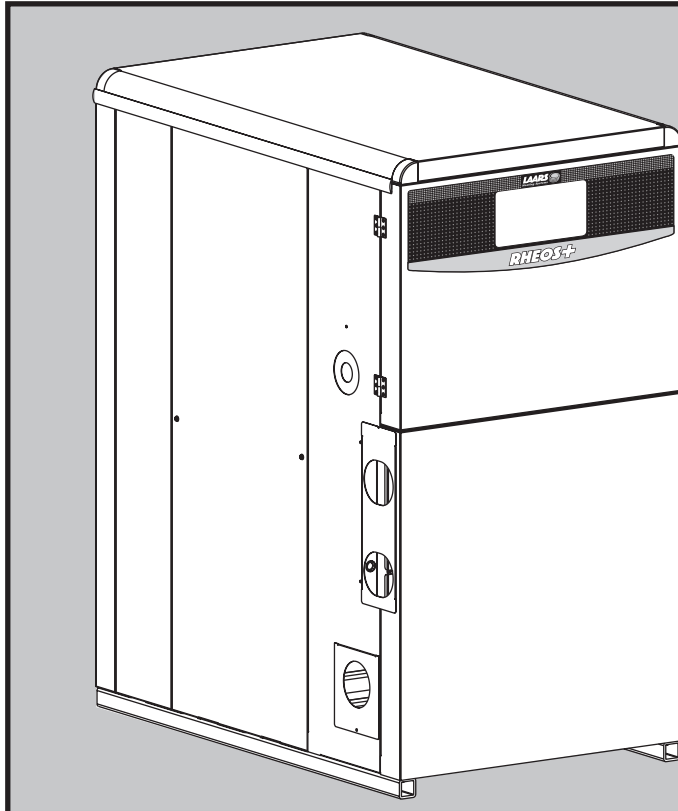

Installation and Operation Instructions for

Rheos+™

Modulating Boiler

Model RHHH

Modulating Water Heater

Model RHHV

U.S. Patent No. 6,644,393

Canada Patent Pending

FOR YOUR SAFETY: This product must be installed and serviced by a professional service technician, qualified in hot water boiler and heater installation and maintenance. Improper installation and/or operation could create carbon monoxide gas in flue gases which could cause serious injury, property damage, or death. Improper installation and/or operation will void the warranty.

⚠ WARNING

If the information in this manual is not followed exactly, a fire or explosion may result causing property damage, personal injury or loss of life.

Do not store or use gasoline or other flammable vapors and liquids in the vicinity of this or any other appliance.

WHAT TO DO IF YOU SMELL GAS

- Do not try to light any appliance.
- Do not touch any electrical switch; do not use any phone in your building.
- Immediately call your gas supplier from a nearby phone. Follow the gas supplier's instructions.
- If you cannot reach your gas supplier, call the fire department.

Installation and service must be performed by a qualified installer, service agency, or gas supplier.

⚠ AVERTISSEMENT

Assurez-vous de bien suivre les instructions données dans cette notice pour réduire au minimum le risque d'incendie ou d'explosion ou pour éviter tout dommage matériel, toute blessure ou la mort.

Ne pas entreposer ni utiliser d'essence ni d'autres vapeurs ou liquides inflammables dans le voisinage de cet appareil ou de tout autre appareil.

QUE FAIRE SI VOUS SENTEZ UNE ODEUR DE GAZ:

- Ne pas tenter d'allumer d'appareils.
- Ne touchez à aucun interrupteur. Ne pas vous servir des téléphones dans le bâtiment où vous vous trouvez.
- Appelez immédiatement votre fournisseur de gaz depuis un voisin. Suivez les instructions du fournisseur.
- Si vous ne pouvez rejoindre le fournisseur de gaz, appelez le service des incendies.

L'installation et l'entretien doivent être assurés par un installateur ou un service d'entretien qualifié ou par le fournisseur de gaz.

Table of Contents

Section 1

General Information

1.1	Introduction	5
1.2	Model Identification	5
1.3	Warranty	6
1.4	Dimensions	6
1.5	Locating the Appliance.....	6
1.6	Locating Pump-Mounted Water Heater with Respect to Storage Tank(s).....	6
1.7	Locating Pump-Mounted Boiler with Respect to Return/Supply Header.....	6
1.8	Locating Appliance for Correct Vent Distance From Outside Wall or Roof Termination.....	7

Section 2

Venting and Combustion Air

2.1	Combustion Air	8
2.1.1	Combustion Air From Room	8
2.1.2	Intake Combustion Air.....	8
2.2	Venting.....	9
2.3	Locating Vent & Combustion Air Terminals.....	9
2.3.1	Horizontal Vent Terminal.....	9
2.3.2	Side Wall Combustion Air Terminal.....	12
2.3.3	Vertical Vent Terminal	12
2.3.4	Vertical Combustion Air Terminal	12
2.4	Common Vent Test – Boilers	12

Section 3

Gas Supply and Piping

3.1	Gas Supply and Piping	13
-----	-----------------------------	----

Section 4A

Water Connections – Rheos+ Boiler

4A.1	Heating System Piping: Hot Supply Connections – Boiler.....	14
4A.2	Cold Water Make-Up – Boiler	14
4A.3	Freeze Protection – Boiler	15

Section 4B

Water Connections – Rheos+ Water Heater

4B.1	Water System Piping – Water Heater	15
4B.2	Hot Water Supply Piping – Water Heater	15
4B.3	Water Flow Requirements – Water Heater....	16
4B.4	Combined Water (potable) Heating and Space Heating.....	18
4B.5	Freeze Protection — Water Heater	19

Section 5

Electrical Connections

5.1	Main Power.....	24
5.2	Pump Connections	24
5.3	Temperature Control – Boiler.....	24
5.4	Temperature Control – Water Heater.....	24
5.4.1	Remote Water Heater Temperature Control..	24
5.4.2	Internal Water Heater Temperature Control...	25
5.5	Temperature Control Features.....	25
5.5.1	Temperature Setpoint	25
5.5.2	Differential Setting	25
5.5.3	Offset	26

5.5.4	Throttling Range	26
5.5.5	Minimum Output Setting	27
5.5.6	Integration Constant	27
5.6	Mixing System and Control.....	28
5.7	External Control Connections	29
5.8	Wiring Diagrams	29

Section 6

Operating Instructions

6.1	Filling the Boiler System	36
6.2	Operating the Burner and Set Up	36
6.3	Shutting Down the Rheos+	38
6.4	To Restart the Rheos+	38

Section 7

Maintenance

7.1	System Maintenance	38
7.2	Appliance Maintenance and Component Description	38
7.2.1	Burner.....	40
7.2.2	Filter.....	40
7.2.3	Modulating Gas Valve.....	40
7.2.4	Safety Gas Valve	41
7.2.5	Manual Reset High Limit Control	41
7.2.6	Temperature Control	41
7.2.7	Auto Reset Temperature Limit	41
7.2.8	Mixing Control.....	41
7.2.9	Mixing Valves.....	41
7.2.10	Mixing Actuator	42
7.2.11	Ignition Control.....	42
7.2.12	Ignitor / Flame Sensor Assembly	42
7.2.13	Transformers	42
7.2.14	Blower.....	42
7.2.15	Flow Switch.....	42
7.2.16	Heat Exchanger Coils.....	42
7.2.17	Normally Open Vent Valve.....	43
7.2.18	Motorized Safety Valve.....	43
7.2.19	Gas Pressure Switches	43

Section 8

Troubleshooting

8.1	Sequence of Operation.....	43
8.2	Resolving Lockouts.....	44
8.3	Delayed Ignition – Possible Causes	44
8.3.1	High Lockup Pressure (LP Appliances) - Occurs on Start-up	44
8.3.2	Gas Valve Regulation	44
8.3.3	Defective Burner - Occurs on Startup or at Burner Shutdown	44
8.4	Short Cycling – Boiler	44
8.5	Short Cycling – Water Heater	45
8.6	High Gas Consumption.....	45

Section 9

Replacement Parts

9.1	General Information	45
9.2	Parts List.....	45

List of Tables

Table 1	Clearances	6	Table 4	Required Combustion Air Piping Material.....	9
Table 2	Vent / Air Pipe Sizes	7	Table 5	Required Venting Material.....	9
Table 3	Horizontal Vent and Air Terminals for Indoor Installations	8	Table 6	Gas Piping Sizes	13
			Table 7	Air & Gas Orifice Differentials at Full Fire.....	38

List of Figures

Figure 1	Dimensional Drawing	7	Figure 19	Wiring Diagram Model 1200, Code B.....	32
Figure 2	Combustion Air and Vent Through Roof.....	8	Figure 20	Wiring Diagram, Models 1600, 2000 and 2400, Code B	33
Figure 3	Combustion Air and Vent Through Side-Wall ..	10	Figure 21	Wiring Schematic, Model 1200, Standard and Codes A and F	34
Figure 4	Hydronic Piping – Multiple Boilers.....	16	Figure 22	Wiring Schematic, Models 1600, 2000 and 2400, Standard and Codes A and F	34
Figure 5	Hydronic Piping – Multiple Boilers (Alternate) .	17	Figure 23	Wiring Schematic, Model 1200, Code B.....	35
Figure 6	Hydronic Piping – One Boiler, Multi-Temperature System	18	Figure 24	Wiring Schematic, Models 1600, 2000 and 2400, Code B	35
Figure 7	Internal Piping Schematic.....	19	Figure 25	Gas/Air Test Panel.....	37
Figure 8	Water Heater Piping – One Heater, One Tank	20	Figure 26	Test Panel Valves	37
Figure 9	Water Heater Piping – Multiple Heaters, One Tank.....	21	Figure 27	Gas Trains	39
Figure 10	Water Heater Piping – One Heater, Multiple Tanks.....	22	Figure 28	Gas Trains	40
Figure 11	Water Heater Piping – Multiple Heaters, Multiple Tanks.....	23	Figure 29	Control Panel.....	41
Figure 12	Temperature Control.....	24	Figure 30	Combustion Components.....	49
Figure 13	Proportional Control	25	Figure 31	Gas Train/Combustion Air Components.....	50
Figure 14	Control Parameter Graph	26	Figure 32	Gas Train Components	51
Figure 15	Control Parameter Graph	27	Figure 33	Electrical Components	52
Figure 16	Control Parameter Possible Interference	28	Figure 34	Heat Exchanger / Water Path Components	53
Figure 17	Wiring Diagram, Model 1200, Standard and Codes A and F	30	Figure 35	Heat Exchanger / Water Path Components	54
Figure 18	Wiring Diagram, Models 1600, 2000 and 2400, Standard and Codes A and F	31	Figure 36	Jacket Components.....	55

Section 1 GENERAL INFORMATION

USING THIS MANUAL – Because the Rheos+ Boilers and Rheos+ Water Heaters are identical appliances, with the exception of materials of manufacture, labels and ultimate use application, this manual provides information for the proper installation, operation and maintenance of both products. Where differences exist between the application of the appliances and their operation, the sections pertinent to only one appliance or the other will be so identified.

⚠ WARNING

The Rheos+ hydronic, boiler or water heater **must** be installed in accordance with the procedures detailed in this manual, or the LAARS Heating Systems warranty will be voided. The installation must conform to the requirements of the local jurisdiction having authority, and, in the United States, to the latest edition of the National Fuel Gas Code, ANSI Z223.1/NFPA54. In Canada, the installation must conform to the latest edition of CSA B149.1 Natural Gas and Propane Gas Installation Code, and/or local codes. Where required by the authority having jurisdiction, the installation of Rheos+ boilers must conform to the Standard for Controls and Safety Devices for Automatically Fired Boilers, ANSI/ASME CSD-1. Any modifications to the boiler, its gas controls, or wiring may void the warranty. If field conditions require modifications, consult the factory representative before initiating such modifications.

1.1 Introduction

This manual provides information necessary for the installation, operation, and maintenance of LAARS Heating Systems Rheos+ (copper tube or cupronickel tubes) appliances. Read it carefully before installation.

All application and installation procedures should be reviewed completely before proceeding with the installation. Consult the LAARS Heating Systems factory, or local factory representative, with any problems or questions regarding this equipment. Experience has shown that most operating problems are caused by improper installation.

The Rheos+ appliance is protected against over pressurization. A pressure relief valve is fitted to all appliances. It is installed inside the jacket, at the water outlet of the unit. (See Sections 4A and 4B for instructions on how to install a relief valve outlet.)

IMPORTANT: The inlet gas pressure to the appliance must not exceed 13" W.C. (3.2kPa).

All installations must be made in accordance with 1) American National Standard Z223.1/NFPA54-Latest Edition “National Fuel Gas Code” or 2) CSA B149.1 “Natural Gas and Propane Installation Code” and with the requirement of the local utility or other authorities having jurisdiction. Such applicable requirements take precedence over the general instructions contained herein.

All electrical wiring is to be done in accordance with the local codes, or in the absence of local codes, with: 1) The National Electrical Code ANSI/NFPA No. 70-latest Edition, or 2) CSA STD. C22.1 “Canadian Electrical Code - Part 1”. This appliance must be electrically grounded in accordance with these codes.

1.2 Model Identification

Consult the rating plate on the unit. The following information describes the model number structure.

- (1-2) Model Series Designation
R H = Rheos+ mid-sized commercial
- (3) Model Efficiency
H = High Efficiency (condensing)
- (4) Usage
H = Hydronic
V = Volume Water
- (5-8) Size
1 2 0 0 = 1,200,000 BTU/hr input
1 6 0 0 = 1,600,000 BTU/hr input
2 0 0 0 = 2,000,000 BTU/hr input
2 4 0 0 = 2,400,000 BTU/hr input
- (9) Fuel
N = Natural Gas
P = Liquid Propane
- (10) Altitude
A = Universal Altitude (0' to 10,000') (0m to 3050m)
- (11) Location
I = Indoor

Model Designation

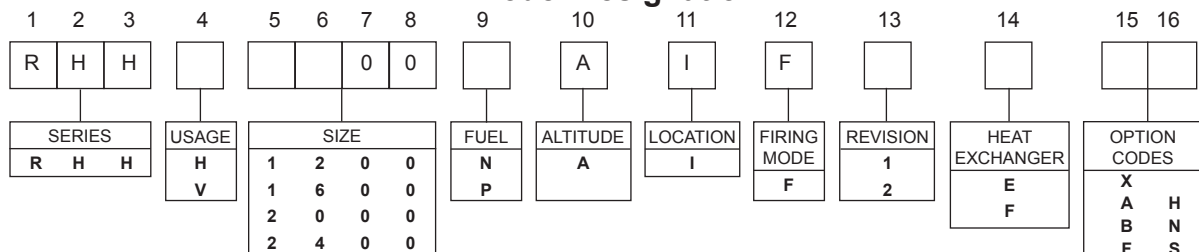

- (12) Firing Mode
F = Modulating
- (13) Revision
2 = Second version
- (14) Heat Exchanger
E = Glass-lined steel with copper tubes
F = Glass-lined steel with cupronickel tubes
- (15) Control Option Code
X = Standard, meets CSD-1 boiler standard
A = Control Pack A: CSD-1, CA, FM, IL, IRI, Alarm Bell
B = Control Pack B: CSD-1, CA, FM, IL, LDS, MN
F = Non CSD-1
- (16) Pump Options
H = Pump mounted, hard water pump
N = Pump mounted, normal pump
S = Pump mounted, soft water pump
(volume water, high efficiency [condensing] model only)

1.3 Warranty

LAARS Heating Systems' Rheos+ appliances are covered by a limited warranty. The owner should fill out the warranty registration card and return it to LAARS Heating Systems.

All warranty claims must be made to an authorized LAARS Heating Systems representative or directly to the factory. Claims must include the serial number and model (this information can be found on the rating plate), installation date, and name of the installer. Shipping costs are not included in the warranty coverage.

Some accessory items are shipped in separate packages. Verify receipt of all packages listed on the packing slip. Inspect everything for damage immediately upon delivery, and advise the carrier of any shortages or damage. Any such claims should be filed with the carrier. The carrier, not the shipper, is responsible for shortages and damage to the shipment whether visible or concealed.

1.4 Dimensions

The overall dimensions are 34.5" (88cm) wide, 65.75" (167cm) tall, 55" (140cm) deep. Other dimensions can be found in Figure 1.

1.5 Locating the Appliance

The Rheos+ is for indoor installations only.

The appliance should be located to provide clearances on all sides for maintenance and inspection. It should not be located in an area where leakage of any connections will result in damage to the area adjacent to the appliance or to lower floors of the structure.

When such a location is not available, it is recommended that a suitable drain pan, adequately drained, be installed under the appliance.

The appliance is design certified by CSA-International for installation on combustible flooring; in basements; in closets, utility rooms or alcoves.

Rheos+ Boilers or Water Heaters must never be

installed on carpeting. The location for the appliance should be chosen with regard to the vent pipe lengths and external plumbing. The unit shall be installed such that the gas ignition system components are protected from water (dripping, spraying, rain, etc.) during operation and service (circulator replacement, control replacement, etc.). When vented vertically, the Rheos+ must be located as close as practical to a chimney or gas vent. If the vent terminal and/or combustion air terminal terminate through a wall, and there is potential for snow accumulation in the local area, both terminals should be installed at an appropriate level above grade.

The dimensions and requirements that are shown in Table 1 should be met when choosing the locations for the appliance:

Appliance Surface	Clearance From Combustible Material		Suggested Service Clearance	
	inches	cm	inches	cm
Piping Side	1	2.5	18	46
Opposite Side	1	2.5	1	2.5
Top	1	2.5	24	61
Back	1	2.5	36	91
Front	1	2.5	36	91
Vent	per UL1738 venting system supplier's instructions			

Table 1 - Clearances

1.6 Locating Pump-Mounted Water Heater with Respect to Storage Tank(s)

For best results the Rheos+ water heater should be located within 15 feet (4.6m) of the storage tank(s). The pump is sized for 30 feet (9.1m) of piping.

Water heater pumps are sized for water hardness; 7.6 to 17 grains per gallon for normal water, greater than 17 grains per gallon for hard water, and 1 to 7.5 grains per gallon for soft water. If the appliance must be installed with longer piping runs, then larger diameter pipe or tubing may be able to be used, in some instances. Consult the factory for assistance.

1.7 Locating Pump-Mounted Boiler with Respect to Return/Supply Header

Rheos+ units must be piped in primary-secondary fashion because of the internal pump and mixing system.

For the best results the Rheos+ Boiler should be located within 15 feet (4.6m) of the supply and return headers. The pump is sized for 30 feet (9.1m) of piping, in most cases, enough for primary-secondary piping systems.

If the appliance must be installed with longer piping runs, then larger diameter tubing may be able to be used, in some instances. Consult the factory for assistance.

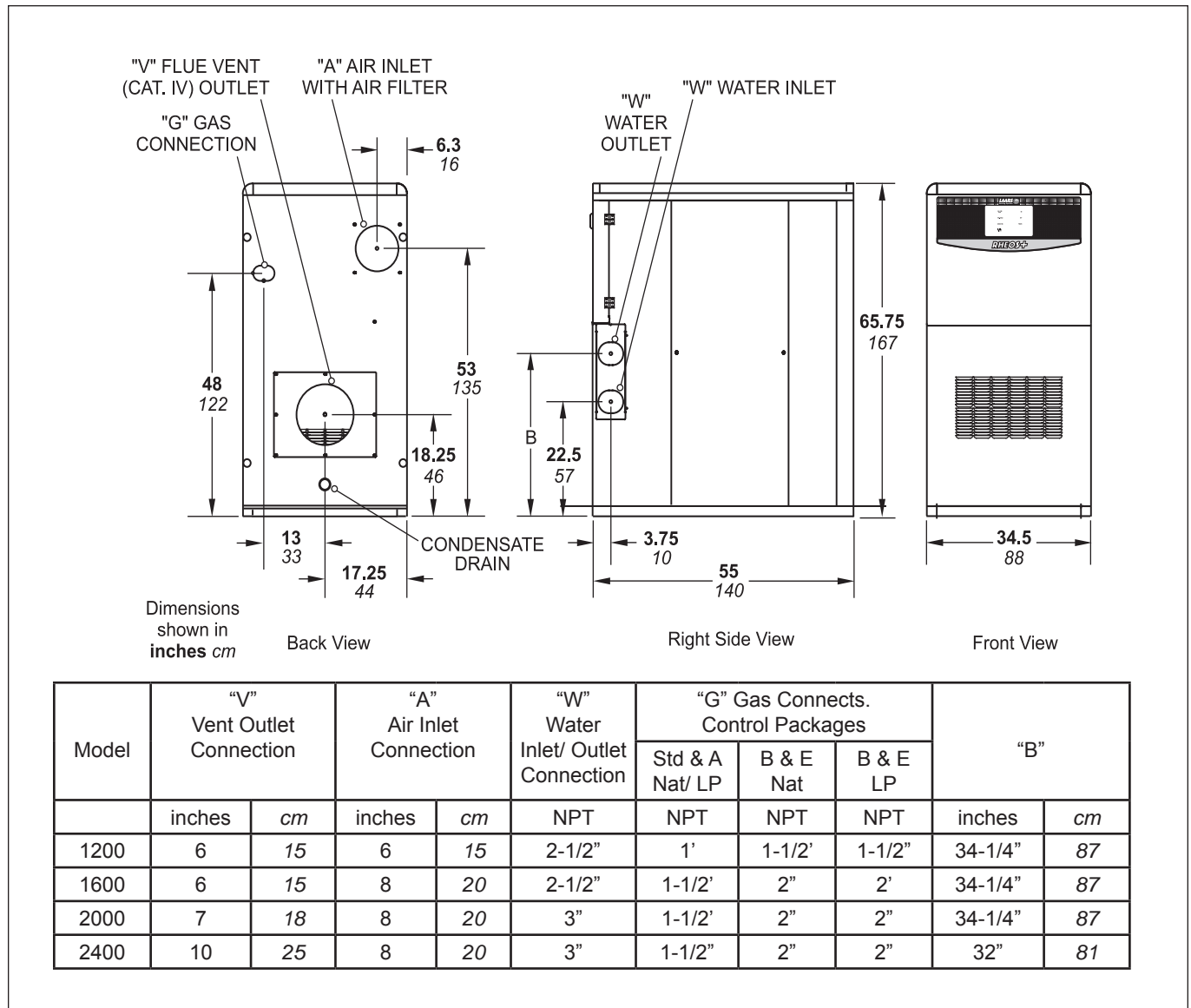

Figure 1 - Dimensional Drawing

Model	Intake Size	Exhaust Size	Intake Maximum Run	Exhaust Maximum Run
1200	6" (15 cm) dia.	6" (15 cm) dia.	50 linear feet with 5 elbows	50 linear feet with 5 elbows
1600	8" (20 cm) dia.	6" (15 cm) dia.	50 linear feet with 5 elbows	50 linear feet with 5 elbows
2000	8" (20 cm) dia.	7" (18 cm) dia.	50 linear feet with 5 elbows	50 linear feet with 5 elbows
2400	8" (20 cm) dia.	10" (25 cm) dia.	50 linear feet with 5 elbows	50 linear feet with 5 elbows

Table 2 - Vent / Air Pipe Sizes

1.8 Locating Appliance for Correct Vent Distance From Outside Wall or Roof Termination

The forced draft combustion air blower in the appliance has sufficient power to vent properly when the guidelines in Table 2 are followed.

NOTE: When located on the same wall, the Rheos+ combustion air intake terminal must be installed a minimum of 12" (30cm) below the exhaust vent terminal and separated by a minimum of 36 inches (91cm) horizontally.

Section 2 VENTING AND COMBUSTION AIR

2.1 Combustion Air

Rheos+ boilers and water heaters must have provisions for combustion and ventilation air in accordance with the applicable requirements for Combustion Air Supply and Ventilation in the National Fuel Gas Code, ANSI Z223.1; or in Canada, the Natural Gas and Propane Installation Code, CSA B149.1. All applicable provisions of local building codes must also be adhered to.

A Rheos+ unit can take combustion air from the space in which it is installed, or the combustion air can be ducted directly to the unit. Ventilation air must be provided in either case.

2.1.1 Combustion Air From Room

In the United States, the most common requirements specify that the space shall communicate with the outdoors in accordance with method 1 or 2, which follow. Where ducts are used, they shall be of the same cross-sectional area as the free area of the openings to which they connect.

Method 1: Two permanent openings, one commencing within 12" (300mm) of the top and one commencing within 12" (300mm) of the bottom, of the enclosure shall be provided. The openings shall communicate directly, or by ducts, with the outdoors or spaces that freely communicate with the outdoors. When directly communicating with the outdoors, or when communicating to the outdoors through vertical ducts, each opening shall have a minimum free area of 1 square inch per 4000 Btu/hr (550 square mm/kW) of total input rating of all equipment in the enclosure. When communicating to the outdoors through horizontal ducts, each opening shall have a minimum free area of not less than 1 square inch per 2000 Btu/hr (1100 square mm/kW) of total input rating of all equipment in the enclosure.

Method 2: One permanent opening, commencing within 12" (300mm) of the top of the enclosure, shall be permitted. The opening shall directly communicate with the outdoors or shall communicate through a vertical or horizontal duct to the outdoors or spaces that directly communicate with the outdoors and shall have a minimum free area of 1 square inch per 3000 Btu/hr (734 square mm/kW) of the total input rating of all equipment located in the enclosure. This opening must not be less than the sum of the areas of all vent connectors in the confined space.

Other methods of introducing combustion and ventilation air are acceptable, providing they conform to the requirements in the applicable codes listed above.

In Canada, consult local building and safety codes or, in absence of such requirements, follow CAN/CGA B149.

2.1.2 Intake Combustion Air

The combustion air can be taken through the wall, or through the roof. When taken from the wall, it must be taken from out-of-doors by means of the LAARS horizontal wall terminal, shown in Table 3. See Table 2 to select the appropriate diameter air pipe. When taken from the roof, a field-supplied rain cap or an elbow arrangement must be used to prevent entry of rain water (see Figure 2).

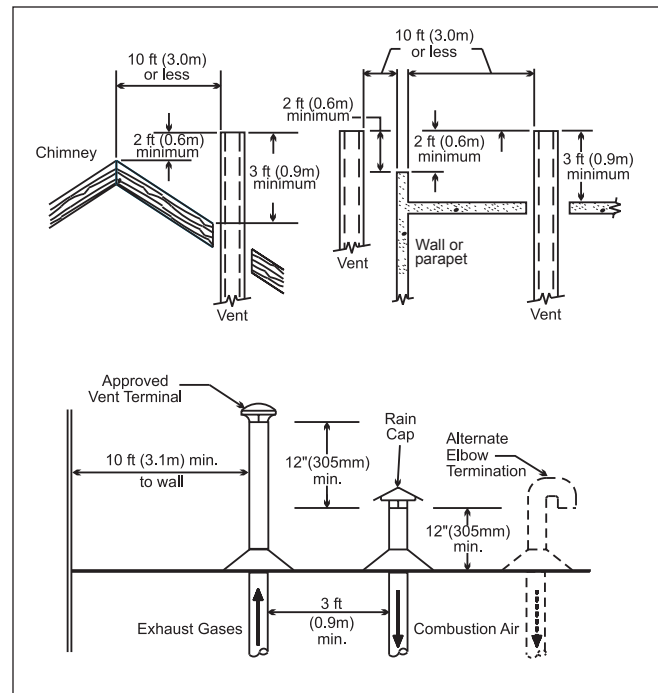

Figure 2 - Combustion Air and Vent Through Roof

Use single-wall galvanized pipe for the combustion air intake (see Table 4), sized per Section 1.8. Route the intake to the heater as directly as possible. Seal all joints with tape. Provide adequate hangers. The unit must not support the weight of the combustion air intake pipe. Maximum linear pipe length allowed is 50 feet (15.2m). Up to five elbows can be used with the 50 feet of pipe. Subtract 10 allowable linear feet for every additional elbow used.

Model	Horizontal Combustion Air Terminal	Horizontal Vent Terminal
1200	20260701	D2004500
1600	20260703	D2004500
2000	20260703	D2004600
2400	20260703	D2006200

Table 3 - Horizontal Vent and Air Terminals for Indoor Installations

Term	Description
Pipe	Single-wall galvanized steel pipe, 24 gauge minimum (sized per section 1.9)
Joint Sealing	Permanent duct tape or aluminum tape
Insulation	Not required, but recommended R5 insulation for cold installations (consult American Society of Heating, Refrigerating, and Air Conditioning Engineers (ASHRAE) handbook)

Table 4 - Required Combustion Air Piping Material.

The connection for the intake air pipe is in the back of the unit. Take the plate off the back to reveal the collar on the filter box. Run a bead of silicone around the collar and slide the pipe over the collar. Secure with sheet metal screws.

In addition to air needed for combustion, air shall also be supplied for ventilation, including all air required for comfort and proper working conditions for personnel. The Rheos+ loses less than 1 percent of its input rating to the room, but other heat sources may be present.

2.2 Venting

The Rheos+ is a Category IV appliance and must be installed with a stainless steel venting system that complies with the UL 1738 Standard (see Table 5). It must be installed per this installation manual and the venting system manufacturer’s Installation Instructions. The unit’s vent can terminate through the roof, or through an outside wall. It can be installed through walls that are from 3" (7.6cm) to 12" (30cm) in thickness.

See Table 2 to select the appropriate vent pipe diameter. The vent pipe must be pitch upward, toward the vent terminal, so that condensate will run back to the Rheos+, to drain. Route the vent pipe to the heater as directly as possible. Seal all joints and provide adequate hangers as required in the venting system manufacturer’s Installation Instructions. Horizontal portions of the venting system must be supported to prevent sagging and may not have any low sections that could trap condensate. The unit must not support the weight of the vent pipe. Horizontal runs must slope upwards not less than ¼ inch per foot (21mm/m) from the unit to the vent terminal. Up to five elbows can be used with the 50 feet (15.2m) of pipe. Subtract 10 allowable linear feet for every additional elbow used.

IMPORTANT NOTE ABOUT COMMON VENTING: A single vent that is shared by multiple Rheos+ units **MUST** be engineered by a competent venting specialist, and involves the selection of draft inducing equipment, hardware and controls to properly balance flue gas pressures. **Do not common vent Rheos+ units unless the vent system meets this requirement. Rheos+ units are never permitted to share a vent with Category I appliances.**

A condensate drain is built into the Rheos+. A pressure switch monitors the condensate drain pan, and will trip if the condensate level gets too high. This will prevent the Rheos+ from firing if there is a blockage or overflow.

Connect a clear plastic tube, minimum 3/8" diameter, between the drain connection and a floor drain (or condensate pump if a floor drain is not accessible).

Caution

Condensate is mildly acidic, and may harm some floor drains and/or pipes, particularly those that are metal. Ensure that the drain, drainpipe, and anything that will come in contact with the condensate can withstand the acidity, or neutralize the condensate before disposal. **Damage caused by failure to install a neutralizer kit or to adequately treat condensate will not be the manufacturer’s responsibility.**

A neutralizer kit is available from LAARS. The kit includes a condensate pump.

The condensate tray must be primed before starting the unit. Fill the tray with water through the exhaust vent connection on the back of the unit. Continue filling until water flows out of the condensate drain port. This prevents the flue gases from escaping through the condensate drain. The condensate drain must be installed so as to prevent accumulation of condensate. When a condensate pump is not used, the tubing must continuously slope downward (except for the trap loop) toward the drain with no spiraling.

Consult local codes for disposal method.

Term	Description
Venting	Sealed stainless steel system certified to UL1738.
Insulation	Not required, but recommended R5 insulation with protective cover for cold installations (consult American Society of Heating, Refrigerating, and Air Conditioning Engineers (ASHRAE) handbook)

Table 5 - Required Venting Material

2.3 Locating Vent & Combustion Air Terminals

2.3.1 Horizontal Vent Terminal

The appropriate Laars side wall vent hood must be used, and is listed in the installation and operation manual. The terminal provides a means of installing the vent piping through the building wall, and must be located in accordance with ANSI Z223.1/NFPA 54 and applicable local codes. In Canada, the installation must be in accordance with CSA B149.1 or .2 and local applicable codes. Consider the following when installing the terminal:

	U.S. Installations (see note 1)	Canadian Installations (see note 2)
A= Clearance above grade, veranda, porch, deck, or balcony	12 inches (30 cm)	12 inches (30 cm)
B= Clearance to window or door that may be opened	4 feet (1.2 m) below or to side of opening; 1 foot (30 cm) above opening	36 inches (91 cm)
C= Clearance to permanently closed window	See note 4	See note 5
D= Vertical clearance to ventilated soffit located above the terminal within a horizontal distance of 2 feet (61cm) from the center line of the terminal	See note 4	See note 5
E= Clearance to unventilated soffit	See note 4	See note 5
F= Clearance to outside corner	See note 4	See note 5
G= Clearance to inside corner	See note 4	See note 5
H= Clearance to each side of center line extended above meter/regulator assembly	See note 4	3 feet (91 cm) within a height 15 feet above the meter/regulator assembly
I= Clearance to service regulator vent outlet	See note 4	3 feet (91 cm)
J= Clearance to nonmechanical air supply inlet to building or the combustion air inlet to any other appliance	4 feet (1.2 m) below or to side of opening; 1 foot (30 cm) above opening	36 inches (91 cm)
K= Clearance to a mechanical air supply inlet	3 feet (91 cm) above if within 10 feet (3 m) horizontally	6 feet (1.83 m)
L= Clearance above paved sidewalk or paved driveway located on public property	Vent termination not allowed in this location for category IV appliances. For Category III appliances, vent must terminate at least 7 feet (2.13m) above the sidewalk or driveway.	Vent termination not allowed in this location for category IV appliances. A vent shall not terminate directly above a sidewalk or paved driveway that is located between two single family dwellings and serves both dwellings. For Category III appliances that do not violate the previous condition, vent must terminate at least 7 feet (2.13m) above the sidewalk or driveway.
M= Clearance under veranda, porch, deck, or balcony	See note 4	12 inches (30 cm) (see note 3)

Notes:

1. In accordance with the current ANSI Z223.1 / NFPA 54 National Fuel Gas Code.
2. In accordance with the current CAN/CGA-B149 Installation Codes.
3. Permitted only if veranda, porch, deck, or balcony is fully open on a minimum of two sides beneath the floor.
4. For clearances not specified in ANSI Z223.1 / NFPA 54, clearance is in accordance with local installation codes and the requirements of the gas supplier.
5. For c□ supplier.

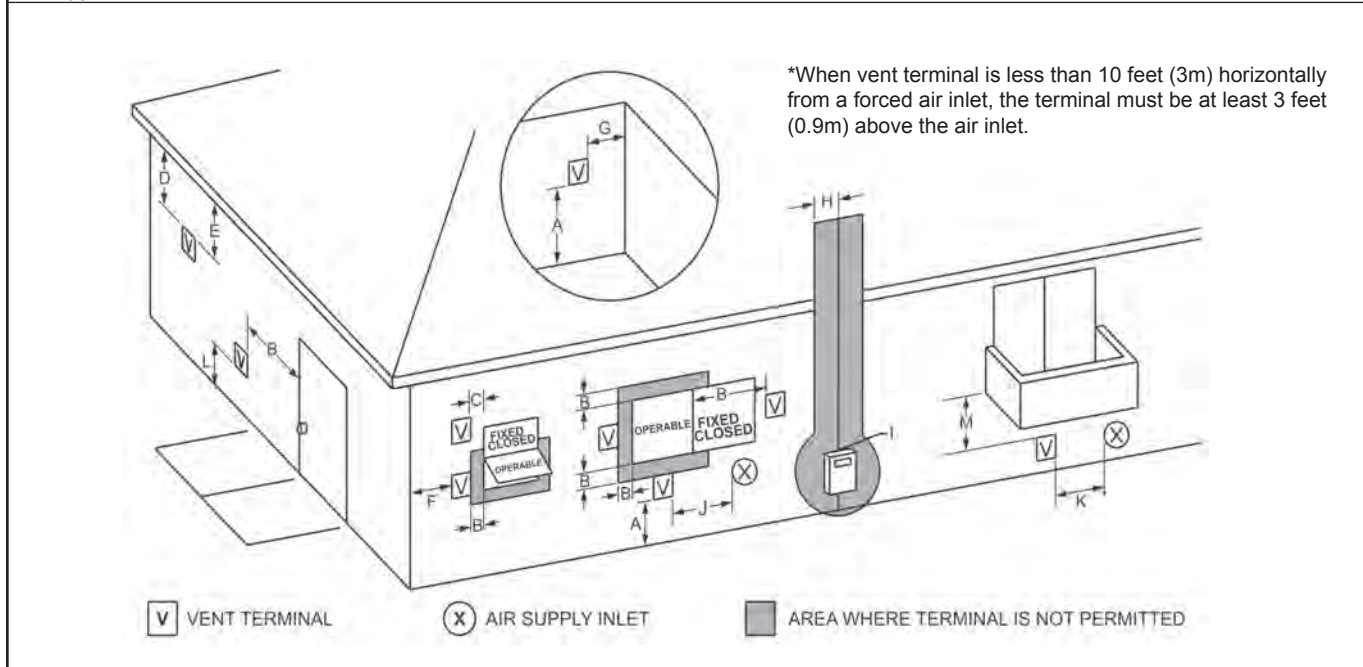

Figure 3 - Combustion Air and Vent Through Side Wall

1. The figure in this addendum shows the requirements for mechanical vent terminal clearances for the U.S. and Canada.
2. Vent terminals for condensing appliances or appliances with condensing vents are **not** permitted to terminate above a public walkway, or over an area where condensate or vapor could create a nuisance or hazard.
3. Locate the vent terminal so that vent gases cannot be drawn into air conditioning system inlets.
4. Locate the vent terminal so that vent gases cannot enter the building through doors, windows, gravity inlets or other openings. Whenever possible, locations under windows or near doors should be avoided.
5. Locate the vent terminal so that it cannot be blocked by snow. The installer may determine that a vent terminal must be higher than the minimum shown in codes, depending upon local conditions.
6. Locate the terminal so the vent exhaust does not settle on building surfaces or other nearby objects. Vent products may damage such surfaces or objects.
7. If the boiler or water heater uses ducted combustion air from an intake terminal located on the same wall, locate the vent terminal at least 3 feet (0.9m) horizontally from the combustion air terminal, and locate the vent terminal at least 1 foot (0.3m) above the combustion air terminal.

**From Massachusetts Rules and Regulations
248 CMR 5.08:**

- (a) **For all side wall horizontally vented gas fueled equipment installed in every dwelling, building or structure used in whole or in part for residential purposes, including those owned or operated by the Commonwealth and where the side wall exhaust vent termination is less than seven (7) feet above finished grade in the area of the venting, including but not limited to decks and porches, the following requirements shall be satisfied:**

1. **INSTALLATION OF CARBON MONOXIDE DETECTORS**
At the time of installation of the side wall horizontal vented gas fueled equipment, the installing plumber or gasfitter shall observe that a hard-wired carbon monoxide detector with an alarm and battery back-up is installed on the floor level where the gas equipment is to be installed. In addition, the installing plumber or gasfitter shall observe that a battery operated or hard-wired carbon monoxide detector with an alarm is installed on each additional level of the dwelling, building or structure served by the side

wall horizontal vented gas fueled equipment. It shall be the responsibility of the property owner to secure the services of qualified licensed professionals for the installation of hard-wired carbon monoxide detectors.

- a. In the event that the side wall horizontally vented gas fueled equipment is installed in a crawl space or an attic, the hard-wired carbon monoxide detector with alarm and battery back-up may be installed on the next adjacent floor level.
- b. In the event that the requirements of this subdivision cannot be met at the time of completion of installation, the owner shall have a period of thirty (30) days to comply with the above requirements; provided, however, that during said thirty (30) day period, a battery operated carbon monoxide detector with an alarm shall be installed.

2. APPROVED CARBON MONOXIDE DETECTORS

Each carbon monoxide detector as required in accordance with the above provisions shall comply with NFPA 720 and be ANSI/UL 2034 listed and IAS certified.

3. SIGNAGE

A metal or plastic identification plate shall be permanently mounted to the exterior of the building at a minimum height of eight (8) feet above grade directly in line with the exhaust vent terminal for the horizontally vented gas fueled heating appliance or equipment. The sign shall read, in print size no less than one-half (½) inch in size, "GAS VENT DIRECTLY BELOW. KEEP CLEAR OF ALL OBSTRUCTIONS."

4. INSPECTION.

The state or local gas inspector of the side wall horizontally vented gas fueled equipment shall not approve the installation unless, upon inspection, the inspector observes carbon monoxide detectors and signage installed in accordance with the provisions of 248 CMR 5.08(2)(a) 1 through 4.

(b) EXEMPTIONS: The following equipment is exempt from 248 CMR 5.08(2)(a) 1 through 4:

1. The equipment listed in Chapter 10 entitled "Equipment Not Required To Be Vented" in the most current edition of NFPA 54 as adopted by the Board; and
2. Product Approved side wall horizontal vented gas fueled equipment installed in a room or structure separate from the dwelling, building or structure used in whole or in part for residential purposes.

(c) MANUFACTURER REQUIREMENTS – GAS EQUIPMENT VENTING SYSTEM PROVIDED. When the manufacturer of Product Approved side wall horizontally vented gas equipment provides a venting system design or venting system components with the equipment, the instructions provided by the manufacturer for installation of the equipment and the venting system shall include:

1. Detailed instructions for the installation of the venting system design or the venting system components; and
2. A complete parts list for the venting system design or venting system.

(d) MANUFACTURER REQUIREMENTS – GAS EQUIPMENT VENTING SYSTEM NOT PROVIDED. When the manufacturer of a Product Approved side wall horizontally vented gas fueled equipment does not provide the parts for venting the fuel gases, but identifies “special venting systems”, the following requirements shall be satisfied by the manufacturer:

1. The identification of each “special venting system” shall include either the listing of the website, phone number or manufacturer’s address where the venting system installation instructions can be obtained; and
2. The “special venting systems” shall be Product Approved by the Board, and the instructions provided with that system shall include a parts list and detailed installation instructions.

(e) A copy of all installation instructions for the Product Approved side wall horizontally vented gas fueled equipment, and all the venting instructions, parts lists, and/or design instructions for the venting system shall remain with the appliance or equipment at the completion of the installation.

Manufacturers' websites where venting system installation instructions may be obtained is located on the Laars website at: <http://www.laars.com>.

2.3.2 Side Wall Combustion Air Terminal

The Laars side wall combustion air terminal (see Table 4) must be used when the heater takes air from a side wall. Consider the following when installing the terminal:

1. Do not locate the air inlet terminal near a source of corrosive chemical fumes (e.g., cleaning fluid, chlorine compounds, etc.)
2. Locate the terminal so that it will not be subject to damage by accident or vandalism. It must be at least 7 feet (2.1m) above a public walkway.
3. Locate the combustion air terminal so that it cannot be blocked by snow. The National Fuel Gas Code requires that it be at least 12 inches (30cm) above grade, but the installer may determine it should be higher, depending upon local conditions.
4. If the Rheos is side-wall vented to the same wall, locate the vent terminal at least 3 feet (0.9m) horizontally from the combustion air terminal, and locate the vent terminal at least 1 foot (0.3m) above the combustion air terminal (see Figure 3).

2.3.3 Vertical Vent Terminal

When the unit is vented through the roof, the vent must extend at least 3 feet (0.9m) above the point at which it penetrates the roof. It must extend at least 2 feet (0.6m) higher than any portion of a building within a horizontal distance of 10 feet (3.0m), and high enough above the roof line to prevent blockage from snow. When the combustion air is taken from the roof, the combustion air must terminate at least 12" (30cm) below the vent terminal (see Figure 2).

2.3.4 Vertical Combustion Air Terminal

When combustion air is taken from the roof, a field-supplied rain cap or an elbow arrangement must be used to prevent entry of rain water (see Figure 2). The opening on the end of the terminal must be at least 12" (30cm) above the point at which it penetrates the roof, and high enough above the roof line to prevent blockage from snow. When the vent terminates on the roof, the combustion air must terminate at least 12" (30cm) below the vent terminal.

2.4 Common Vent Test — Boilers

NOTE: This section does not describe a method for common venting Rheos+ units. It describes what must be done when a unit is removed from a common vent system. Rheos+ units require special vent systems and fan for common vent. Contact the factory if you have questions about common venting Rheos+ units.

When an existing boiler is removed from a common venting system, the common venting system is likely to be too large for proper venting of the appliances remaining connected to it.

At the time of removal of an existing boiler, the following steps shall be followed with each appliance remaining connected to the common venting system placed in operation, while the other appliances remaining connected to the common venting system are not in operation.

1. Seal any unused openings in the common venting system.
2. Visually inspect the venting system for proper size and horizontal pitch and determine there is no blockage or restriction, leakage, corrosion and other deficiencies which could cause an unsafe condition.
3. Insofar as it is practical, close all building doors and windows and all doors between the space in which the appliances remaining connected to the common venting system are located and other spaces of the building. Turn on clothes dryers and any appliance not connected to the common venting system. Turn on any exhaust fans, such as range hoods and bathroom exhausts, so they will operate at maximum speed. Do not operate a summer exhaust fan. Close fireplace dampers.
4. Place in operation the appliance being inspected. Follow the lighting instructions. Adjust thermostat so appliance will operate continuously.
5. Test for spillage at the draft hood relief opening after 5 minutes of main burner operation. Use the flame of a match or candle, or smoke from a cigarette, cigar or pipe.
6. After it has been determined that each appliance remaining connected to the common venting system properly vents when tested as outlined above, return doors, windows, exhaust fans, fireplace dampers and any other gas burning appliance to their previous conditions of use.
7. Any improper operation of the common venting system should be corrected so that the installation conforms to the National Fuel Gas Code, ANSI Z223.1/NFPA 54 and/or CSA B149.1, Installation Codes. When resizing any portion of the common venting system, the common venting system should be resized to approach the minimum size

as determined using the appropriate tables and guidelines in the National Fuel Gas Code, ANSI Z223.1 NFPA 54 and/or CSA B149.1, Installation Codes.

Section 3 GAS SUPPLY AND PIPING

3.1 Gas Supply and Piping

Gas piping should be supported by suitable hangers or floor stands, not the appliance.

Review the following instructions before proceeding with the installation.

1. Verify that the appliance is fitted for the proper type of gas by checking the rating plate. LAARS Heating Systems appliances are normally equipped to operate at elevations up to 2000 feet (610m). However, the appliance will function properly without the use of high altitude modification at elevations up to 10,000 feet (3050 m).
2. The maximum inlet gas pressure must not exceed 13" W.C. (3.2kPa). The minimum inlet natural gas pressure is 4" W.C. (1.0kPa) and minimum inlet propane gas pressure is 6" (1.5kPa).
3. Refer to Table 6, size supply.
4. Run gas supply line in accordance with all applicable codes.
 Note: If you have a boiler/water heater with a normally open vent valve, install a vent line from the vent valve to an outside location as required by your installation code or IRI requirement. **Do not remove 3/4 inch pipe plug from the vent valve if venting from the normally open vent valve is not required by your installation code.**
5. Locate and install manual shutoff valves in accordance with state and local requirements.
6. A sediment trap must be provided upstream of the gas controls.

Model and Gas Type	Distance from Gas Meter or Last Stage Regulator							
	0-50 feet	0-15m	50-100 feet	15-31m	100-200 feet	31-61m	200-300 feet	61-91m
1200 natural	2"	5.1cm	2-1/2"	6.4cm	2-1/2"	6.4cm	3"	7.6cm
1200 propane	1-1/2"	3.8cm	2"	5.1cm	2"	5.1cm	2-1/2"	6.4cm
1600 natural	2-1/2"	6.4cm	2-1/2"	6.4cm	3"	7.6cm	3"	7.6cm
1600 propane	2"	5.1cm	2"	5.1cm	2-1/2"	6.4cm	2-1/2"	6.4cm
2000 natural	3"	7.6cm	3"	7.6cm	3"	7.6cm	3-1/2"	8.9cm
2000 propane	2-1/2"	6.4cm	2-1/2"	6.4cm	2-1/2"	6.4cm	3"	7.6cm
2400 natural	2-1/2"	6.4cm	3"	7.6cm	3"	7.6cm	3-1/2"	8.9cm
2400 propane	2"	5.1cm	2-1/2"	6.4cm	2-1/2"	6.4cm	3"	7.6cm

Notes: 1. These figures are based on 1/2" 0.12kPa water column pressure drop.
 2. Check supply pressure and local code requirements before proceeding with work.
 3. Pipe fittings must be considered when determining gas pipe sizing.

Table 6 - Gas Piping Sizes

7. All threaded joints should be coated with piping compound resistant to action of liquefied petroleum gas.
8. The appliance and its individual shutoff valve must be disconnected from the gas supply piping during any pressure testing of that system at test pressures in excess of 1/2 PSIG (3.45kpa).
9. The unit must be isolated from the gas supply system by closing its individual manual shutoff valve during any pressure testing of the gas supply piping system at test pressures equal to or less than 1/2 PSIG (3.45kpa).
10. The appliance and its gas connection must be leak tested before placing it in operation.
11. Purge all air from gas lines.

⚠ WARNING

Open flame can cause gas to ignite and result in property damage, severe injury, or loss of life.

NOTE: The Rheos+ appliance and all other gas appliances sharing the gas supply line must be firing at maximum capacity to properly measure the inlet supply pressure. The pressure can be measured at the supply pressure port on the gas valve. Low gas pressure could be an indication of an undersized gas meter, undersized gas supply lines and/or an obstructed gas supply line. A bleed line from the diaphragm-type automatic valve shall be vented per local code requirements. Rheos+ units are equipped with low and high gas pressure switches that are integrally vent limited. These types of devices do not require venting to atmosphere.

Section 4A WATER CONNECTIONS — RHEOS+ BOILER

4A.1 Heating System Piping: Hot Supply Connections — Boiler

NOTE: This appliance must be installed in a closed pressure system with a minimum of 12 psi (82.7kPa) static pressure at the boiler.

Hot water piping should be supported by suitable hangers or floor stands. Do not support piping with this appliance. Due to expansion and contraction of copper pipe, consideration should be given to the type of hangers used. Rigid hangers may transmit noise through the system resulting from the piping sliding in the hangers. It is recommended that padding be used when rigid hangers are installed. Maintain 1" (2.5cm) clearance to combustibles for hot water pipes.

Pipe the discharge of the relief valve (full size)

to a drain or in a manner to prevent injury in the event of pressure relief. Install an air purger, an air vent, a diaphragm-type expansion tank, and a hydronic flow check in the system supply loop. Minimum fill pressure must be 12psig (82.7kPa). Install shutoff valves where required by code.

Suggested piping diagrams are shown in Figures 4, 5, and 6. These diagrams are meant only as a guide. Components required by local codes must be properly installed. The Rheos+ boiler's efficiency is higher with lower return water temperatures. Therefore, to get the most of low return temperature with multiple boilers, pipe as shown in Figure 4.

The Rheos+ boiler has an internal mixing system that ensures that the condensation does not occur on the finned copper heat exchanger, with boiler return temperature down to 50°F (10°C). **This system, that consists of automatically actuated and linked valves, is set up at the factory, and is non-adjustable.** The return water goes through the stainless steel heat exchanger, then to the mixing system (see Figure 7).

If the water at the inlet of the copper heat exchanger is less than 140°F (60°C), water from the outlet of the copper heat exchanger will be directed back to the inlet of the copper heat exchanger, and will mix to bring the inlet water up to 140°F (60°C). Once through the copper heat exchanger, the water picks up another 20-25°F (11-14°C) (when at high fire), and it leaves the boiler at 160-165°F (71-74°C). This hot water is then sent to the system.

If the water at the inlet of the copper heat exchanger is 140°F (60°C), or higher, the water will be allowed to flow through the copper heat exchanger and directly to the outlet of the Rheos+, and there will be a 20-25°F (11-14°C) temperature rise between the inlet and outlet of the unit, when the unit is at high fire.

The pump in the boiler is sized for the boiler's heat exchangers, the internal mixing system, and 30 feet of full-sized piping, with a normal number of fittings taken into consideration. The piping must be primary/secondary, ensuring that the boiler's pump is only used for the boiler, and that the system pump(s) do not interfere with the Rheos+ pump or mixing system.

The minimum inlet water temperature for the Rheos+ is 50°F (10°C) to avoid condensing on the copper coils.

4A.2 Cold Water Make-Up — Boiler

1. Connect the cold water supply to the inlet connection of an automatic fill valve.
2. Install a suitable back flow preventer between the automatic fill valve and the cold water supply.
3. Install shut off valves where required.

NOTE: The boiler, when used in connection with a refrigeration system, must be installed so the chilled

medium is piped in parallel with the boiler with appropriate valves to prevent the chilled medium from entering the boiler.

The boiler piping system of a hot water heating boiler connected to heating coils located in air handling appliances where they may be exposed to refrigerated air circulation must be equipped with flow control valves or other automatic means to prevent gravity circulation of the boiler water during the cooling cycle.

A boiler installed above radiation level, or as required by the authority having jurisdiction, must be provided with a low water cutoff device either as a part of the boiler or at the time of boiler installation.

4A.3 Freeze Protection – Boiler

Rheos+ units are not designed to be placed outdoors, due to the potential for condensate to freeze in the unit.

Proper precautions for freeze protection are recommended for boiler installations in areas where the danger of freezing exists.

Power outage, interruption of gas supply, failure of system components, activation of safety devices, etc., may prevent a boiler from firing. **Any time a boiler is subjected to freezing conditions, and the boiler is not able to fire, and/or the water is not able to circulate, there is a risk of freezing in the boiler or in the pipes in the system.** When water freezes, it expands. This can result in bursting of pipes in the system, or damage to the boiler, which could result in leaking or flooding conditions.

Do not use automotive anti-freeze. Maintaining a mixture of minimum 50% water and maximum 50% properly inhibited HVAC glycol, which contains an antifoamant, is the preferred method of freeze protection for Rheos+ boilers. **The percentage of glycol used in the Rheos+ boiler must not exceed 50%.** Typically, this mixture will serve as burst protection for temperatures down to approximately -35°F (-30°C).

IMPORTANT NOTES: Different glycol products may provide varying degrees of protection. Glycol products must be maintained properly in a heating system, or they may become ineffective. Consult the glycol specifications, or the glycol manufacturer, for information about specific products, maintenance of solutions, and set up according to your particular conditions.

For installations where temperatures are expected to fall below 15°F inside the boiler cabinet, the actuating gas valve must be equipped with a gas valve heater, LAARS part number R2010100. Note that some gas trains such as the IRI option may have double actuators, and may require 2 gas valve heaters.

Section 4B WATER CONNECTIONS — RHEOS+ WATER HEATER

4B.1 Water System Piping — Water Heater

Hot water piping should be supported by suitable hangers or floor stands. Do not support piping with this appliance. Due to expansion and contraction of copper pipe, consideration should be given to the type of hangers used. Rigid hangers may transmit noise through the system resulting from the piping sliding in the hangers. It is recommended that padding be used when rigid hangers are installed.

The Rheos+ can be used with several different types of readily available storage tanks. A pump draws water from the storage tank and pumps the water through the heater and back into the tank. Pump-mounted units have a circulating pump built into the water heater.

Pipe the outlet from the heater's relief valve such that any discharge from the relief valve will be conducted to a suitable place for disposal when relief occurs. Do not reduce line size or install any valves in this line. The line must be installed to allow complete drainage of both the valve and the line.

Suggested piping diagrams are shown in Figures 8, 9, 10, and 11. These diagrams are meant only as a guide. Components required by local codes must be properly installed.

The minimum inlet water temperature for the Rheos+ is 50°F (10°C) to avoid condensing on the copper coils.

4B.2 Hot Water Supply Piping — Water Heater

Follow the tank manufacturer's guidelines for completion of the hot water system connections.

NOTE: A listed temperature and pressure relief valve listed as complying with the Standard for Relief Valves and Automatic Gas Shutoff Devices for Hot Water Supply Systems, 1). ANSI Z21.22 latest edition, or 2). CSA 4.4, of suitable discharge capacity must be installed in the separate storage tank system.

If the Rheos+ water heater is installed in a closed water supply system, such as one having a backflow preventer in the cold water supply line, the relief valve may discharge periodically, due to thermal expansion. Means (such as a properly-sized expansion tank) shall be provided to control thermal expansion. Contact the water supplier or local plumbing inspector on how to control this situation.

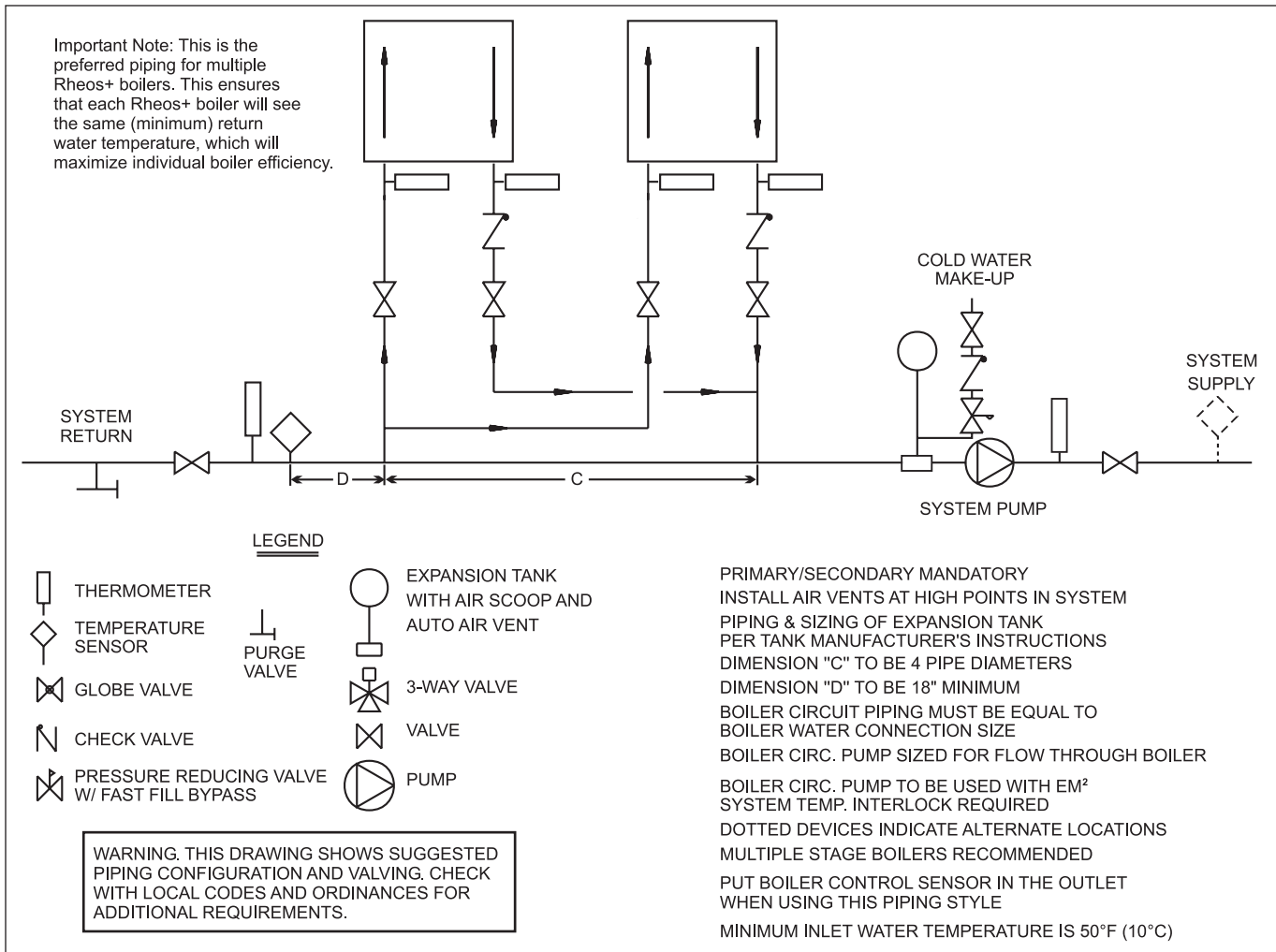

Figure 4 - Hydronic Piping - Multiple Boilers

4B.3 Water Flow Requirements — Water Heater

In a water heating application (an open system), new water is constantly being introduced. With the new water comes a fresh supply of minerals that can be deposited on the unit's heat exchanger. This is commonly known as scaling. The amount of minerals will depend upon the hardness of the water. Water can also be aggressive, and can erode metals, including copper, if the water is moved too quickly. Pump sizing for the Rheos+ water heater is based upon the hardness of the water. The water flow is kept high enough to prevent scaling, but low enough to prevent tube

erosion. For extremely soft or hard water, cupro-nickel tubes are available. Contact a LAARS Representative if you have questions or concerns about water quality.

The Rheos+ water heater has an internal mixing system that ensures that the condensation does not occur on the finned copper heat exchanger, with heater return temperature down to 50°F (10°C). **This system, that consists of automatically actuated and linked valves, is set up at the factory, and is non-adjustable.** The return water goes through the stainless steel heat exchanger, then to the mixing system. (see Figure 7).

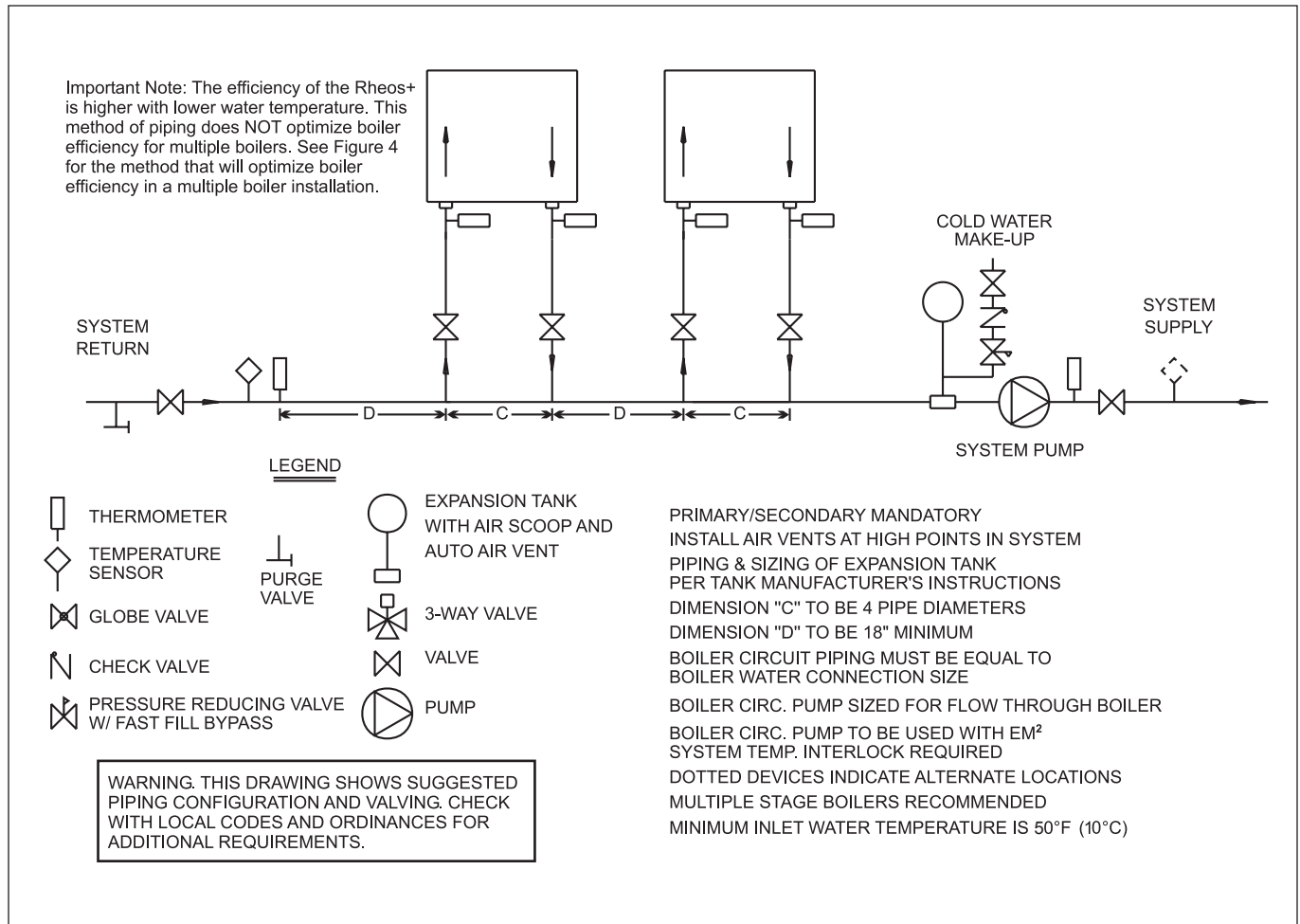

Figure 5 - Hydronic Piping — Multiple Boilers (Alternate)

If the water at the inlet of the copper heat exchanger is less than 140°F (60°C), water from the outlet of the copper heat exchanger will be directed back to the inlet of the copper heat exchanger, and will mix to bring the inlet water up to 140°F (60°C). Once through the copper heat exchanger, the water picks up another 20-25°F (11-14°C) (when at high fire), and it leaves the boiler at 160-165°F (71-74°C). This hot water is then sent to the system.

If the water at the inlet of the copper heat exchanger is 140°F (60°C), or higher, the water will be allowed to flow through the copper heat exchanger and

directly to the outlet of the Rheos+, and there will be a 20-25°F (11-14°C) temperature rise between the inlet and outlet of the unit, when the unit is at high fire.

The pump in the heater is sized for the heater's heat exchangers, the internal mixing system, and 30 feet of full-sized piping, with a normal number of fittings taken into consideration.

The minimum inlet water temperature for the Rheos+ is 50°F (10°C) to avoid condensing on the copper coils.

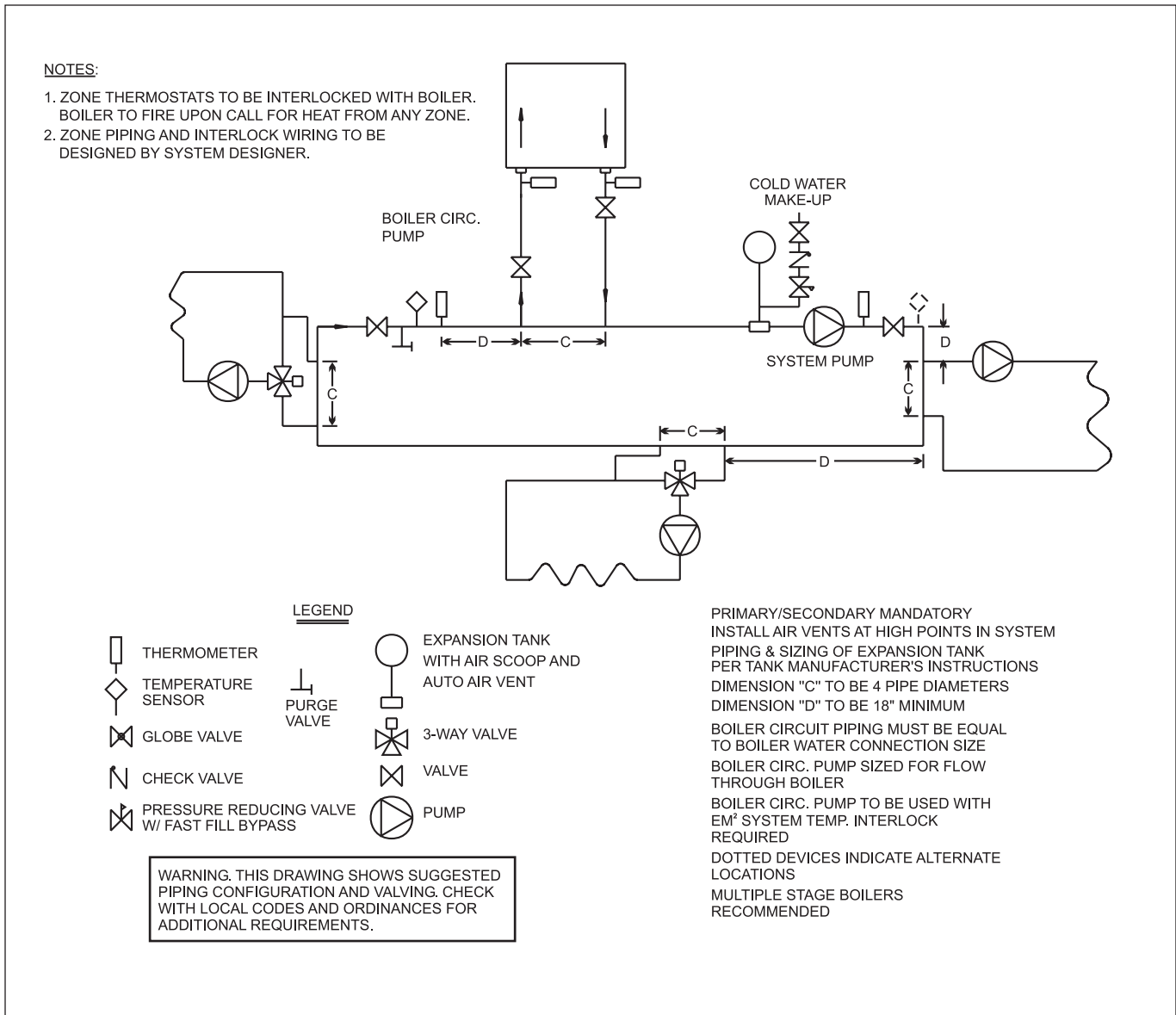

Figure 6 - Hydronic Piping — One Boiler, Multi-Temperature System

4B.4 Combined Water (potable) Heating and Space Heating

NOTE: These systems are not allowed in the Commonwealth of Massachusetts.

Piping and components connected to this water heater for the space heating application shall be suitable for use with potable water.

Toxic chemicals, such as used for boiler treatment, shall not be introduced into the potable

water used for space heating.

This water heater when used to supply potable water shall not be connected to any heating system or component(s) previously used with a non-potable water heating appliance.

When the system requires water for heating at temperatures higher than required for other uses, an anti-scald mixing or tempering valve shall be installed to temper the water for those uses in order to reduce scald hazard potential.

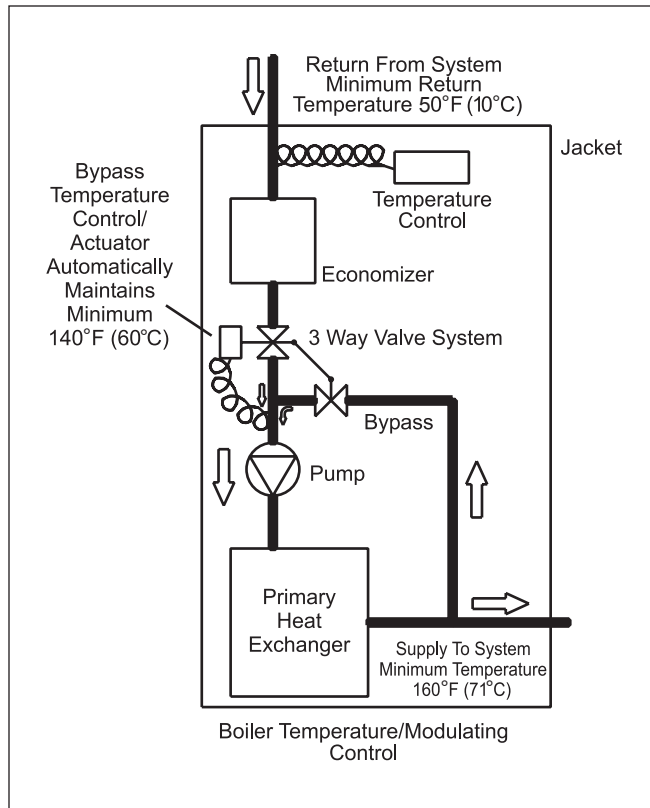

Figure 7 - Internal Piping Schematic

4B.5 Freeze Protection – Water Heater

Rheos+ heaters are not designed to be placed outdoors, due to the potential for condensate to freeze in the unit.

Power outage, interruption of gas supply, failure of system components, activation of safety devices, etc., may prevent a heater from firing. **Any time a heater is subjected to freezing conditions, and the heater is not able to fire, and/or the water is not able to circulate, there is a risk of freezing in the heater or in the pipes in the system.** When water freezes, it expands. This can result in bursting of pipes in the system, or damage to the heater, which could result in leaking or flooding conditions.

For installations where temperatures are expected to fall below 15°F inside the boiler cabinet, the actuating gas valve must be equipped with a gas valve heater, LAARS part number R2010100. Note that some gas trains such as the IRI option may have double actuators, and may require two gas valve heaters.

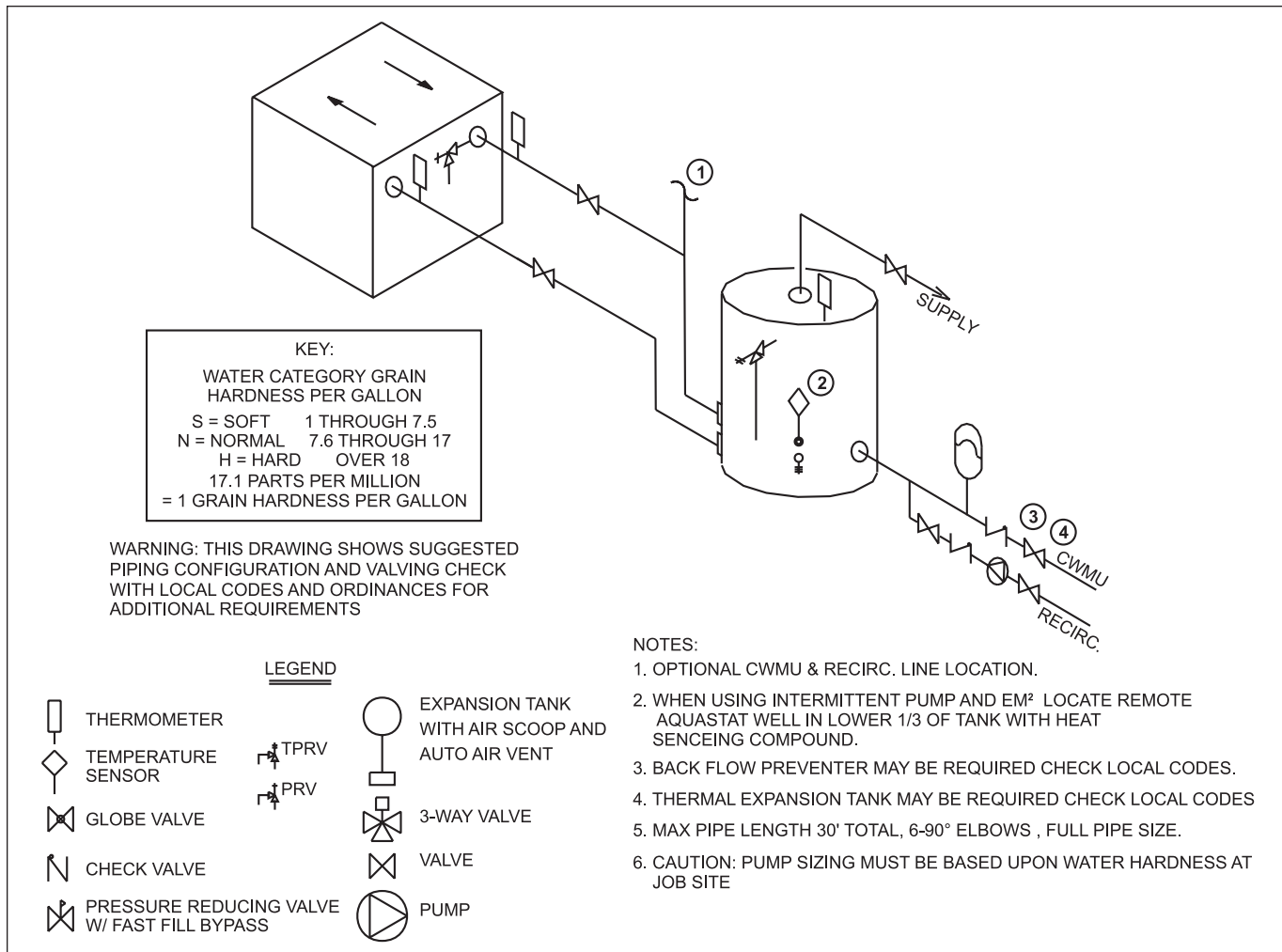

Figure 8 - Water Heater Piping — One Heater, One Tank

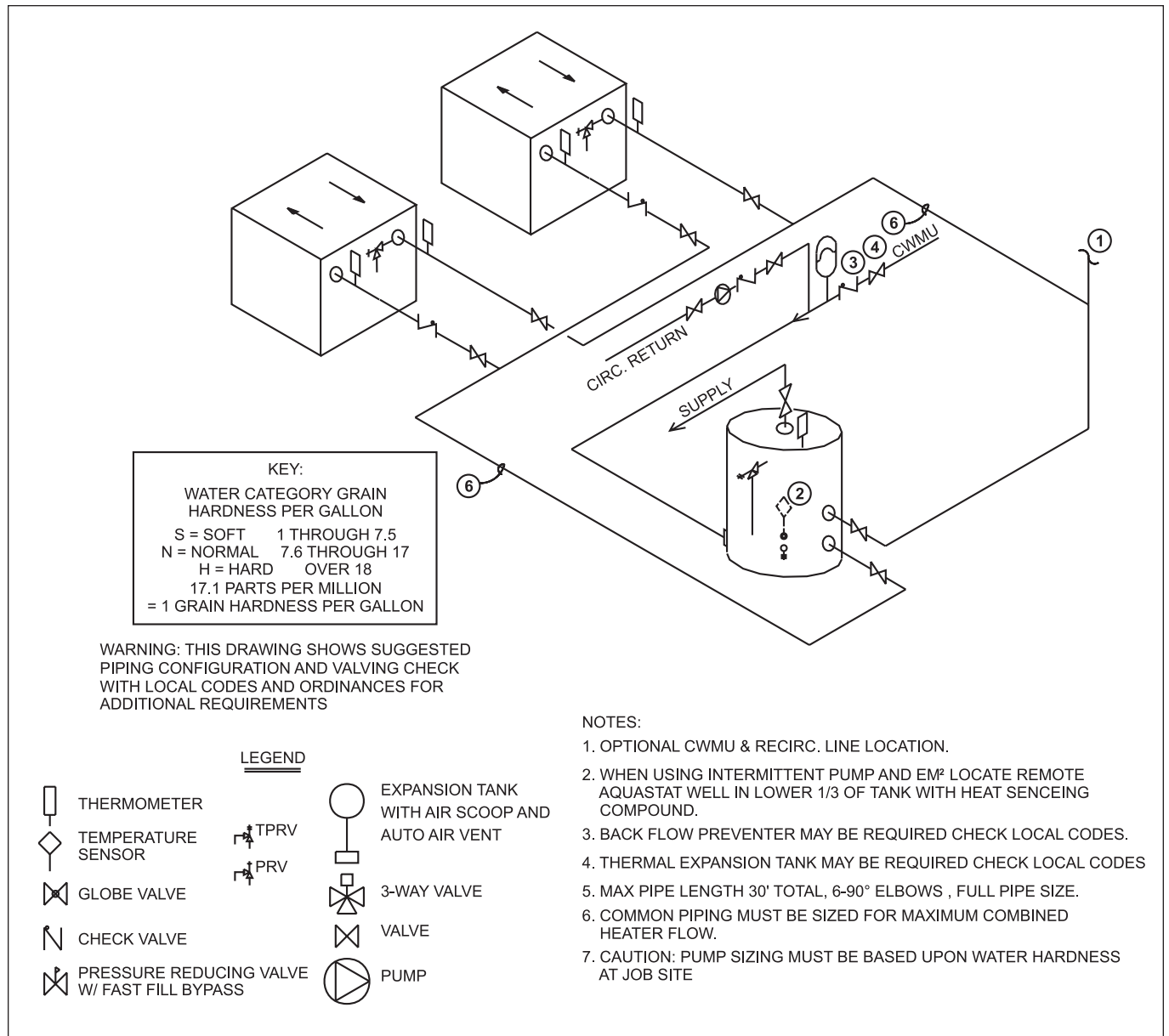

Figure 9 - Water Heater Piping — Multiple Heaters, One Tank

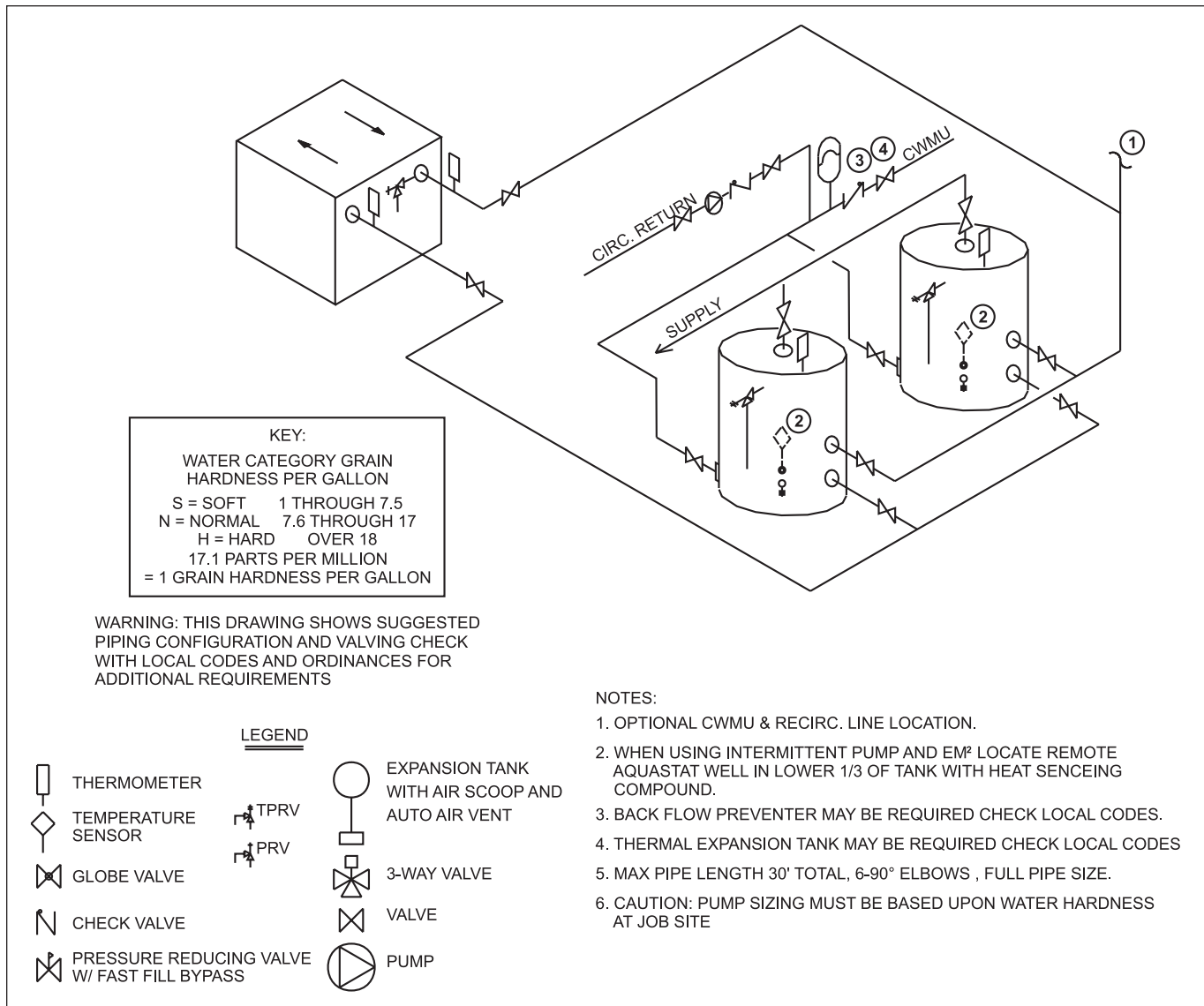

Figure 10 - Water Heater Piping — One Heater, Multiple Tanks

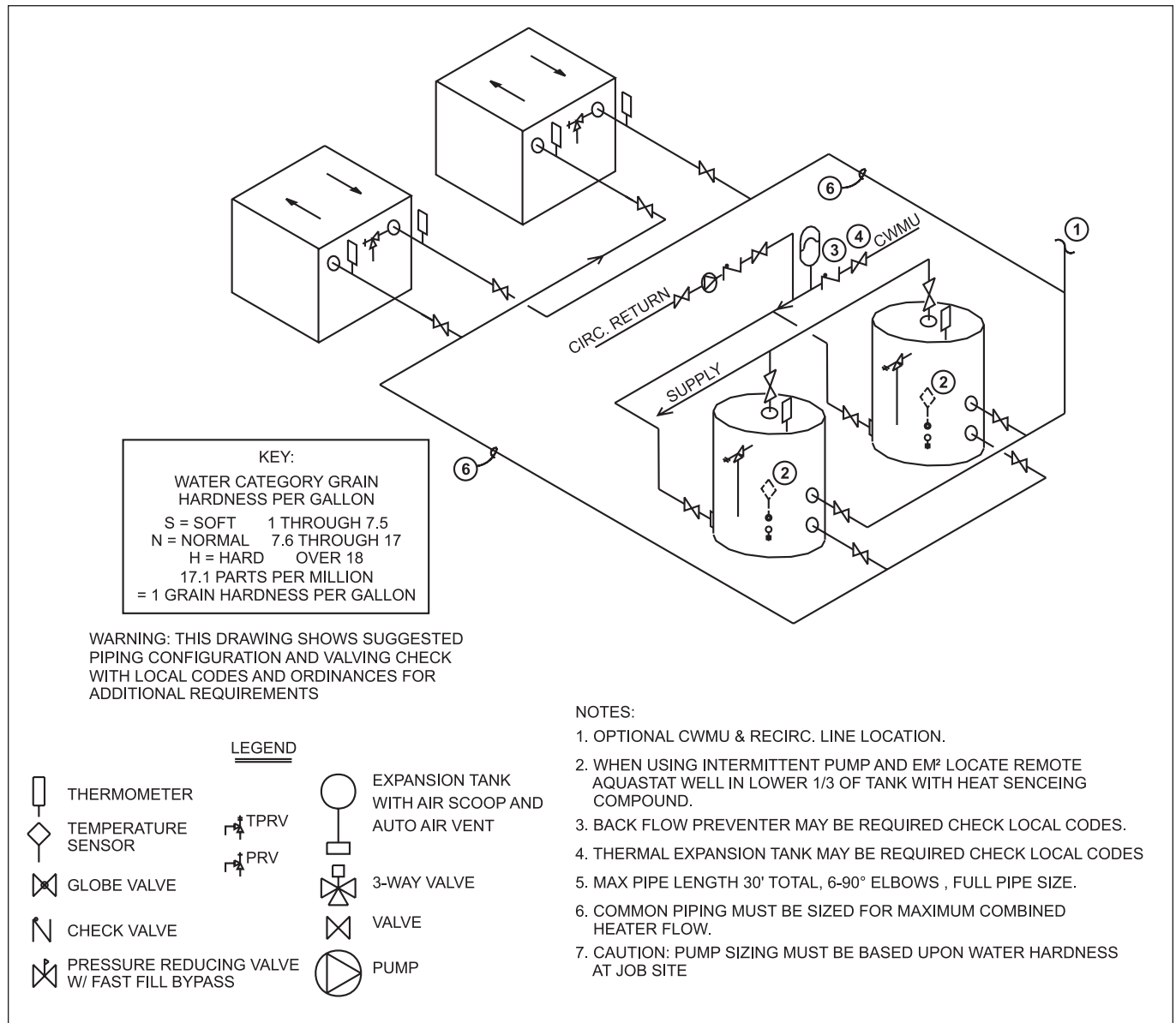

Figure 11 - Water Heater Piping — Multiple Heaters, Multiple Tanks

Section 5

ELECTRICAL CONNECTIONS

⚠ WARNING

The appliance must be electrically grounded in accordance with the requirements of the authority having jurisdiction or, in the absence of such requirements, with the latest edition of the National Electrical Code, ANSI/NFPA 70, in the U.S. and with latest edition of CSA C22.1 Canadian Electrical Code, Part 1, in Canada. Do not rely on the gas or water piping to ground the metal parts of the boiler. Plastic pipe or dielectric unions may isolate the boiler electrically. Service and maintenance personnel, who work on or around the boiler, may be standing on wet floors and could be electrocuted by an ungrounded boiler. Electrocution can result in severe injury or death.

Single pole switches, including those of safety controls and protective devices must not be wired in a grounded line.

All electrical connections are made in the field wiring box that is located inside the appliance.

NOTE: All internal electrical components have been prewired. No attempt should be made to connect electrical wires to any other location except the wiring box.

Wiring connections are shown in Figures 17 through 24.

5.1 Main Power

Connect a properly sized and fused, 120-volt supply to the main power switch (hot leg is connected directly to switch). Neutral leg is connected directly to the white wire. Ground wire can be connected to the grounding screw in the box or on the switch.

5.2 Pump Connections

The pump time delay relay will call the pump to be energized upon a call for heat, and will keep the pump energized for a delay period after the call for heat has ended. The delay period is adjustable from 0.1 to 10 minutes.

Rheos+ units have pumps that are wired at the factory to the pump time delay system. It is necessary to wire the pump to a separate 115V or 230V single phase circuit, per the wiring diagrams in Figures 17 through 20.

5.3 Temperature Control — Boiler

Connect boiler field interlock wires to isolated contacts on zone valves, circulator relays, sequencing controls (multiple boiler applications) or other temperature controlling devices.

The Rheos+ temperature control measures

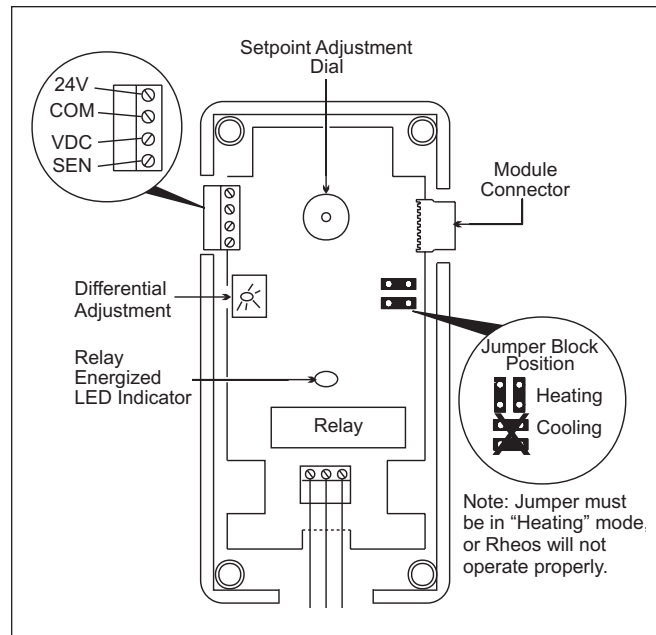

Figure 12 - Temperature Control

temperature on the boiler inlet, sensing return water temperature. Set the temperature control for the desired return temperature. If the return water temperature is less than 140°F (60°C), internal mixing will keep the outlet temperature at 160-165°F (71-74°C). If the return temperature is 140°F (60°C) or higher, the outlet temperature of the boiler will be the return temperature plus 20-25°F (11-14°C) when the Rheos+ is at high firing rate.

The manual reset high limit is on the outlet of the Rheos+. Set the manual reset high limit at about 20°F (11°C) higher than the highest expected outlet temperature, to avoid nuisance lockouts.

5.4 Temperature Control — Water Heater

5.4.1 Remote Water Heater Temperature Control

The Rheos+ water heater can be used with a field-supplied tank aquastat, sequencing control, or other temperature control device, which will call the unit for heat when the temperature goes below the controller's setpoint. For the most efficient setting, set the tank temperature at the lowest possible setting for adequate hot water in the application.

⚠ Caution

If the tank temperature control is set too high, a potential for hot water scalding may exist.

After a setting has been chosen for the tank temperature control, set the heater temperature control 10°F (6°C) higher. The Rheos+ temperature control measures temperature on the heater inlet, sensing return water temperature. If the return water

temperature is less than 140°F (60°C), internal mixing will keep the outlet temperature at 160-165°F (71-74°C), and this will mix with the tank temperature to maintain a lower temperature in the tank. If the return temperature is 140°F (60°C) or higher, the outlet temperature of the heater will be the return temperature plus 20-25°F (11-14°C) when the Rheos+ is at high firing rate.

The manual reset high limit is on the outlet of the Rheos+. Set the manual reset high limit at about 20°F (11°C) higher than the highest expected outlet temperature, to avoid nuisance lockouts

5.4.2 Internal Water Heater Temperature Control

When an external control is not used, the circulator between the heater and the storage tank must run continuously, so that the heater's temperature control can detect and control the water temperature in the storage tank. The Rheos+ water heater's temperature control is adjusted to its lowest temperature position when shipped from the factory. This is the preferred starting point for setting the temperature control.

The Rheos+ temperature control measures temperature on the heater inlet, sensing return water temperature. If the return water temperature is less than 140°F (60°C), internal mixing will keep the outlet temperature at 160-165°F (71-74°C), and this will mix with the tank temperature to maintain a lower temperature in the tank. If the return temperature is 140°F (60°C) or higher, the outlet temperature of the heater will be the return temperature plus 20-25°F (11-14°C) when the Rheos+ is at high firing rate.

The manual reset high limit is on the outlet of the Rheos+. Set the manual reset high limit at about 20°F (11°C) higher than the highest expected outlet temperature, to avoid nuisance lockouts.

⚠ Caution

Should overheating occur or the gas supply fail to shut off, turn off the manual gas control valve to the appliance.

5.5 Temperature Control Features

The Rheos+ temperature control is versatile and will allow the user to better match the modulating control to the application. Settings that can be changed are temperature setpoint, differential, offset, throttling range, and minimum output.

The temperature setpoint is the setting at which the unit will shut off, having satisfied the controller's call for heat.

The differential determines how far the temperature in the Rheos+ can fall before energizing again.

The offset determines where the throttling range begins.

The throttling range is the temperature range through which the unit will modulate from minimum to maximum firing rate.

Important Note: These control parameters work together. Therefore, setting one parameter may have an affect on another. Figures 14, 15 and 16 show the relationships between these settings. Figure 14 follows the examples that are shown in the following sections, and Figures 15 and 16 are examples of how the parameters can interfere with each other.

5.5.1 Temperature Setpoint

The temperature setpoint is the point at which the temperature control relay will be de-energized and the unit's call for heat will end. The temperature setpoint is adjusted with the setpoint dial on the A350 control (see Figure 13). The temperature control's sensor is in the inlet of the unit.

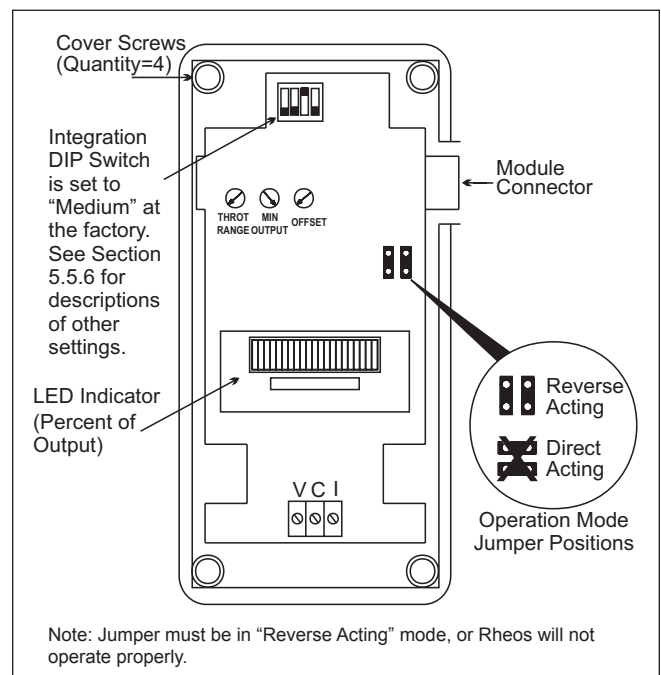

Figure 13 - Proportional Control

5.5.2 Differential Setting

The differential is the difference in temperature settings when the temperature control's relay is energized and de-energized. For instance, if the temperature setpoint is 120°F (49°C) and the differential is 20°F (11°C), the temperature control will call the unit to energize at 100°F (38°C). (The differential is the setpoint minus the differential setting) The call for heat will end when the unit reaches its setpoint of 120°F (49°C). The Rheos+ differential is adjustable from 1°F to 30°F (1°C to 17°C). In general, the differential setting for a water heater system will be low, so that when a storage tank

is drawing down, the heater will react to sustain a minimum tank temperature. Boilers generally have higher differentials than water heaters, to minimize short cycling (see throttling range). The differential is set by removing the cover of the A350 control and adjusting the potentiometer marked “DIFF” (see Figure 13).

5.5.3 Offset

The offset determines the temperature below the controller’s setpoint where the throttling range begins. It offsets the throttling range.

For instance, if the setpoint is 120°F (49°C) and the offset is 5°F (3°C), then the unit’s throttling range will begin at 115°F (46°C). Between 115°F (46°C) and 120°F (49°C), the Rheos+ will be in low fire.

The offset can be adjusted between 0°F and 30°F (0°C and 17°C) by removing the cover of the S350P control and adjusting the Offset dial (see Figure 14).

5.5.4 Throttling Range

The throttling range allows the Rheos+ to match the BTU demands of varying systems, by allowing the user to choose the temperature range through which

the unit will modulate. This will tell the controller how fast to respond to a change in temperature. A small throttling range keeps the unit in high fire more, and quickens the response of the system. A larger throttling range allows the Rheos+ to spread its modulating range over a larger temperature range.

Example, Imperial units: Using a temperature setpoint of 120°F, with a 20°F differential, a 5°F offset, and a throttling range of 10°F, the unit will come on at 100°F and shut off at 120°F. The offset will set the top of the throttling range 5°F under the setpoint, which is 115°F in this example. Therefore, the throttling range will cause the Rheos+ to modulate between 25% and 100% of full fire between 115°F and 105°F. Between 115°F and 120°F, the unit will remain at low fire. Between 100°F and 105°F, the unit will be at full fire.

Example, Metric units: Using a temperature setpoint of 49°C, with a 11°C differential, a 3°C offset, and a throttling range of 5°C, the unit will come on at 38°C and shut off at 49°C. The offset will set the top of the throttling range 3°C under the setpoint, which is 46°C in this example. Therefore, the throttling range will cause the Rheos+ to modulate between 25% and 100% of full fire between 46°C and 41°C. Between

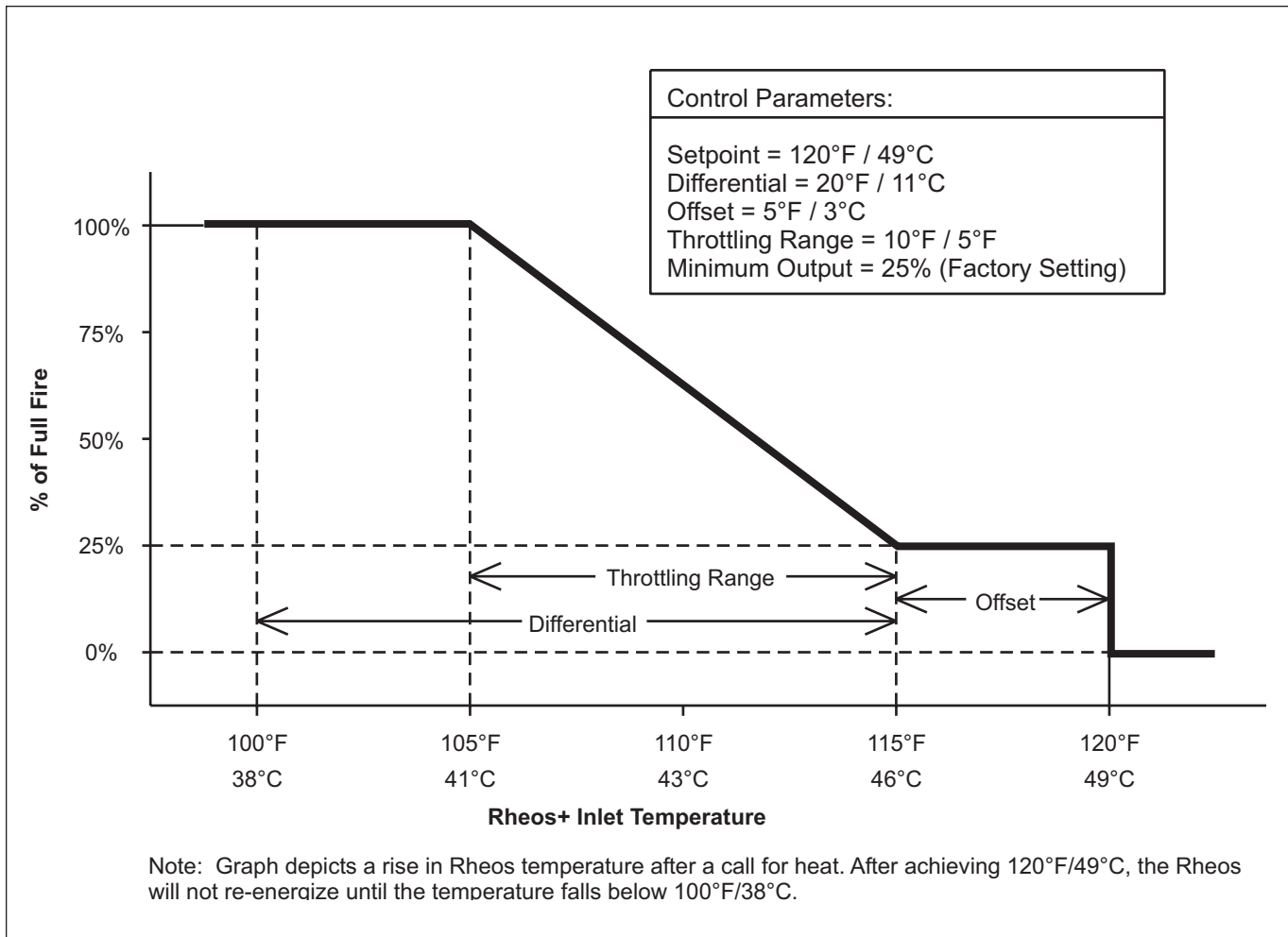

Figure 14 - Control Parameter Graph

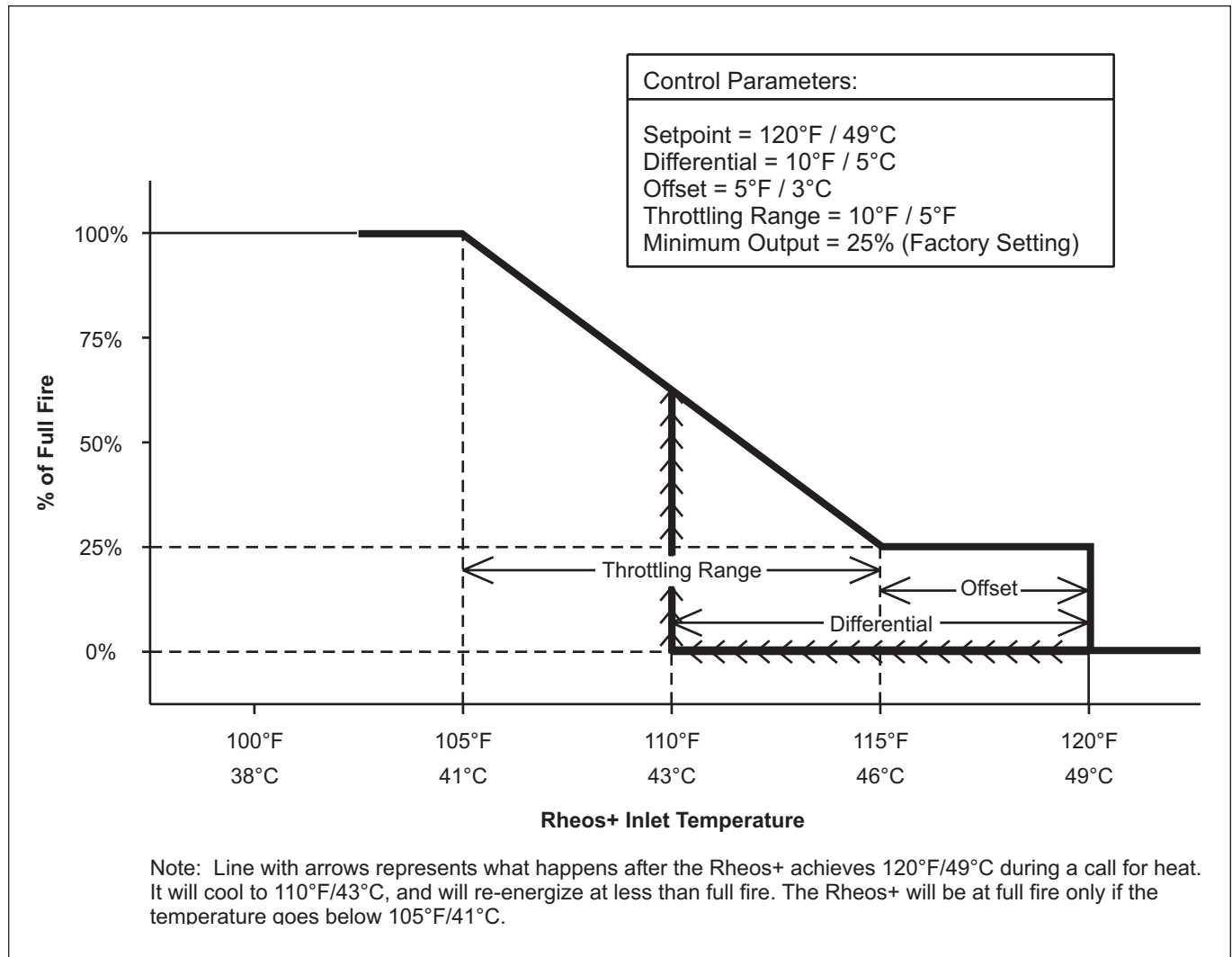

Figure 15 - Control Parameter Graph

46°C and 49°C, the unit will remain at low fire.

Between 38°C and 41°C, the unit will be at full fire.

The throttling range is adjustable between 2°F and 30°F (1°C to 17°C). The range can be set by removing the cover of the S350P control and adjusting the “THROT RANGE” dial (see Figure 14).

5.5.5 Minimum Output Setting

The minimum output setting of the controller is 0% of full fire. However, the minimum output of the Rheos+ is limited to 25% of full fire by the fan speed controller, to ensure proper operation of the Rheos+. If a minimum desired output is higher than 25%, the setting can be adjusted up by removing the cover of the S350P control and adjusting the Min Output dial (see Figure 14). Turning the dial clockwise increases the minimum output. In most cases, this setting should be left as shipped from the factory.

5.5.6 Integration Constant

The proportional control used on the Rheos+ has internal circuitry that helps to minimize overshoot that can sometimes be associated with proportional plus integral (PI) controls. There are three field-selectable integration constants (slow, medium and fast), and an off position on the proportional control, which are selected with the dipswitches on the control (see Figure 14). In most cases, this setting will not need to be changed

Off: Switch 1 to ON position and all others to OFF. Setting the control to the “Off” position puts the control into proportional only operation. This is not a recommended setting for the Rheos+.

Slow: Switch 2 to ON position and all others to OFF. This is the slowest integration constant. It allows the Rheos+ the most time to reach its setpoint. In most cases, this is too slow for Rheos+ installations.

Medium: Switch 3 to ON position and all others to OFF. The integration constant is set to “Medium” at the factory, and in most cases, will not need to be

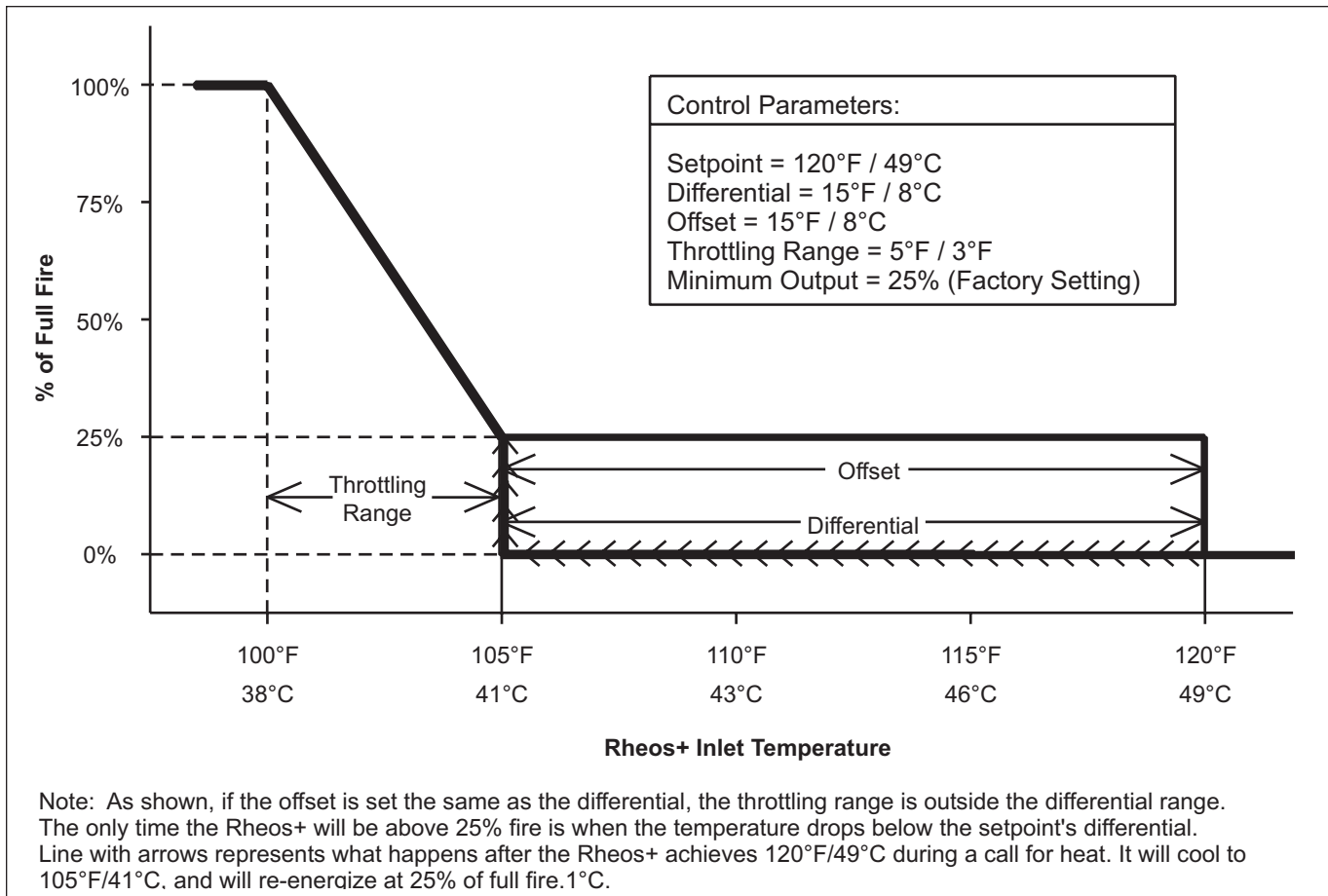

Figure 16 - Control Parameter Possible Interference

changed. This setting will be the best suited to most Rheos+ installations.

Fast: Switch 4 to ON position and all others to OFF. If the rate of system recovery to setpoint is sluggish with the control set to medium, the “Fast” setting may be an improvement. The “Fast” setting will only be used when the rate of change at the sensor is very rapid. In most cases, this setting is too fast for the Rheos+.

5.6 Mixing System and Control

The Rheos+ has an internal mixing system that ensures that the condensation does not occur on the finned copper heat exchanger, with boiler return temperature down to 70°F (21°C). **This system, that consists of automatically actuated and linked valves, is set up at the factory, and is non-adjustable.** The return water goes through the stainless steel heat exchanger, then to the mixing system (see Figure 7).

If the water at the inlet of the copper heat exchanger is less than 140°F (60°C), water from the outlet of the copper heat exchanger will be directed back to the inlet of the copper heat exchanger, and will mix to bring the inlet water up to 140°F (60°C). Once through the copper heat exchanger, the water picks up

another 20-25°F (11-14°C) (when at high fire), and it leaves the boiler at 160-165°F (71-74°C). This hot water is then sent to the system.

If the water at the inlet of the copper heat exchanger is 140°F (60°C), or higher, the water will be allowed to flow through the copper heat exchanger and directly to the outlet of the Rheos+, and there will be a 20-25°F (11-14°C) temperature rise between the inlet and outlet of the unit, when the unit is at high fire.

The by-pass mixing control displays the mixed water temperature, which is the temperature of the water that is sent to the copper heat exchanger. This temperature setting is locked and cannot be changed in the field.

By pressing and holding the two buttons on the left of the mixing control for at least 3 seconds, the user will access two available menus.

The first menu allows selection of the temperature units. Pressing the two left buttons for at least 3 seconds displays “Uni” on the screen (for units). Then “°F” is displayed. Press the up or down arrow on the control to change from °F to °C, or °C to °F. When the preferred selection is displayed, press the enter (bottom left) button. The control will then display “Add” for the second menu. If no more buttons are pushed, the control will automatically return to the temperature display mode.

The second menu “Add” has to do with the N2 address. Pressing enter when “Add” is displayed will display “255”, which stands for 255 unique addresses. The up and down arrows change this value, and enter saves the value if it is changed.

Changing the “Add” value will have no affect on the Rheos+, unless a communications card as been built onto the unit. If a Rheos+ unit has been ordered with an optional communications card, more menus will be active, and the unit will come with separate instructions.

5.7 External Control Connections

Rheos+ units are built with a selector switch and a terminal strip to allow the Rheos+ to receive a 0-10VDC signal from an external controller (such as a building automation system or multiple boiler control).

When the selector switch is in the “Rheos+ Control” position, the Rheos+ will be modulated by the unit’s factory-mounted modulating control.

When the switch is in the “External Control” position, the unit look for a 0-10VDC signal from an external (field-supplied) controller.

To interlock the external boiler control with the Rheos+, the call for heat signal **MUST** be connected to the field interlock terminal strip on the Rheos+ (shown in Figure 29). Be sure to remove the factory-installed jumper between the field interlock terminals. The 0-10VDC modulating signal **MUST** be connected to external control terminal strip, located to the right of, and behind the front panel. The terminal strip is

labeled “0-10VDC +” and 0-10VDC –” to indicate which terminal received the hot signal (+) and which terminal receives the common signal (-) from the controller.

The Rheos+ unit will modulate between 2.23V and 10V (for 25% and 100%, respectively). Anything less than 2.23 volts will result in 25% of full fire.

For the external control to modulate the Rheos+, the selector switch on the front panel must be in the “External Control” position.

Important Note: DO NOT MAKE/BREAK RHEOS+ LINE VOLTAGE TO SIGNAL CALL FOR HEAT. A “call for heat / end call for heat” **MUST** be connected to the field interlock terminals. The Rheos+ does not recognize 0 volts as a signal to shut off. If the call for heat is not connected between the field interlock terminals, the Rheos+ will remain in low fire when it sees 0 volts as a modulating signal.

Caution

Rheos+ supply voltage must not be disengaged, except for service or isolation, or unless otherwise instructed by procedures outlined in this manual. To signal a call for heat, use the 24V field-interlock, as shown in the wiring diagram(s).

Some Rheos+ components are designed to have constant voltage during normal operation. If Rheos+ supply voltage is toggled as a call for heat signal, premature failure of these components may result.

5.8 Wiring Diagrams

Caution

Label all wires prior to disconnection when servicing controls. Wiring errors can cause improper and dangerous operation. Verify proper operation after servicing.

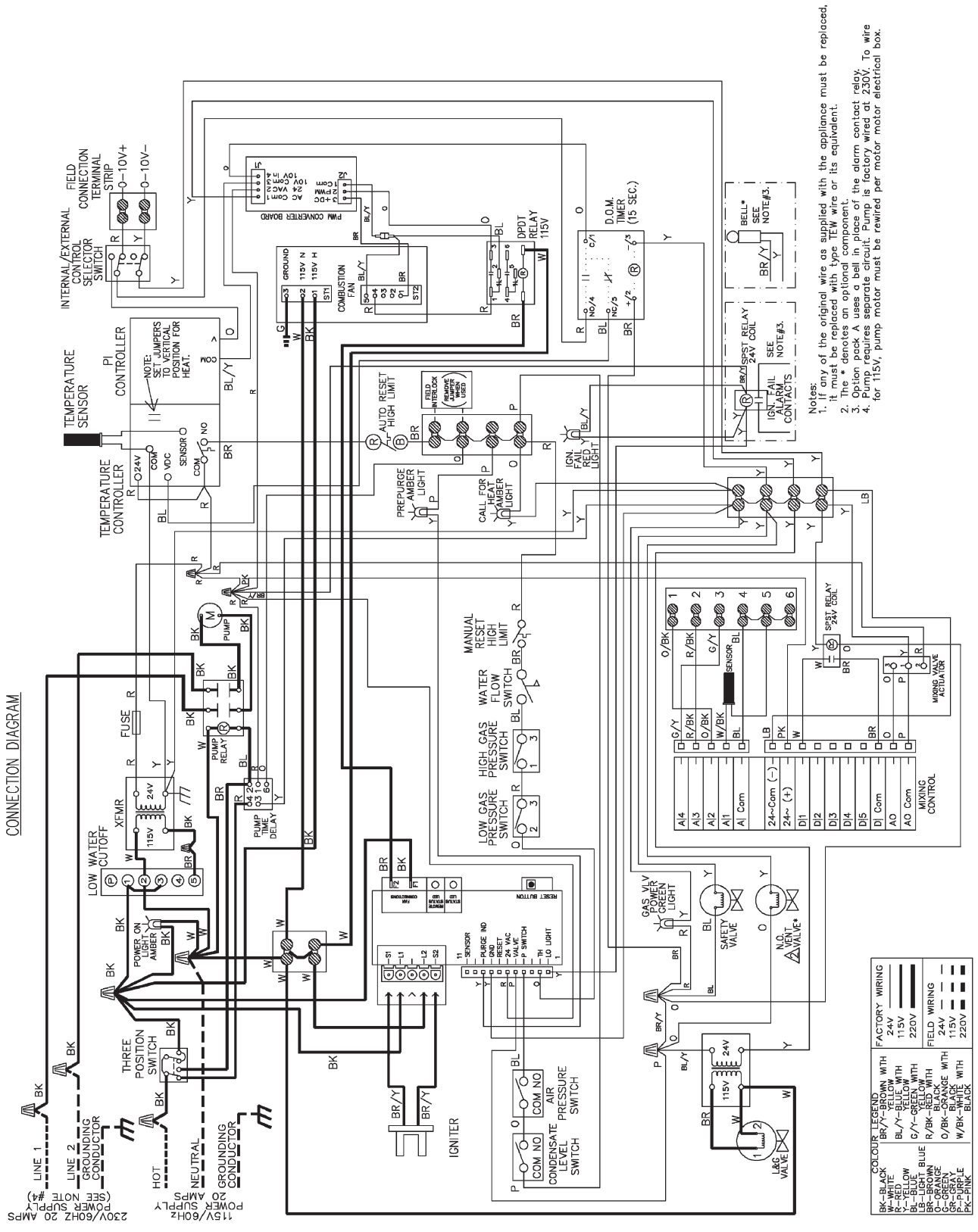
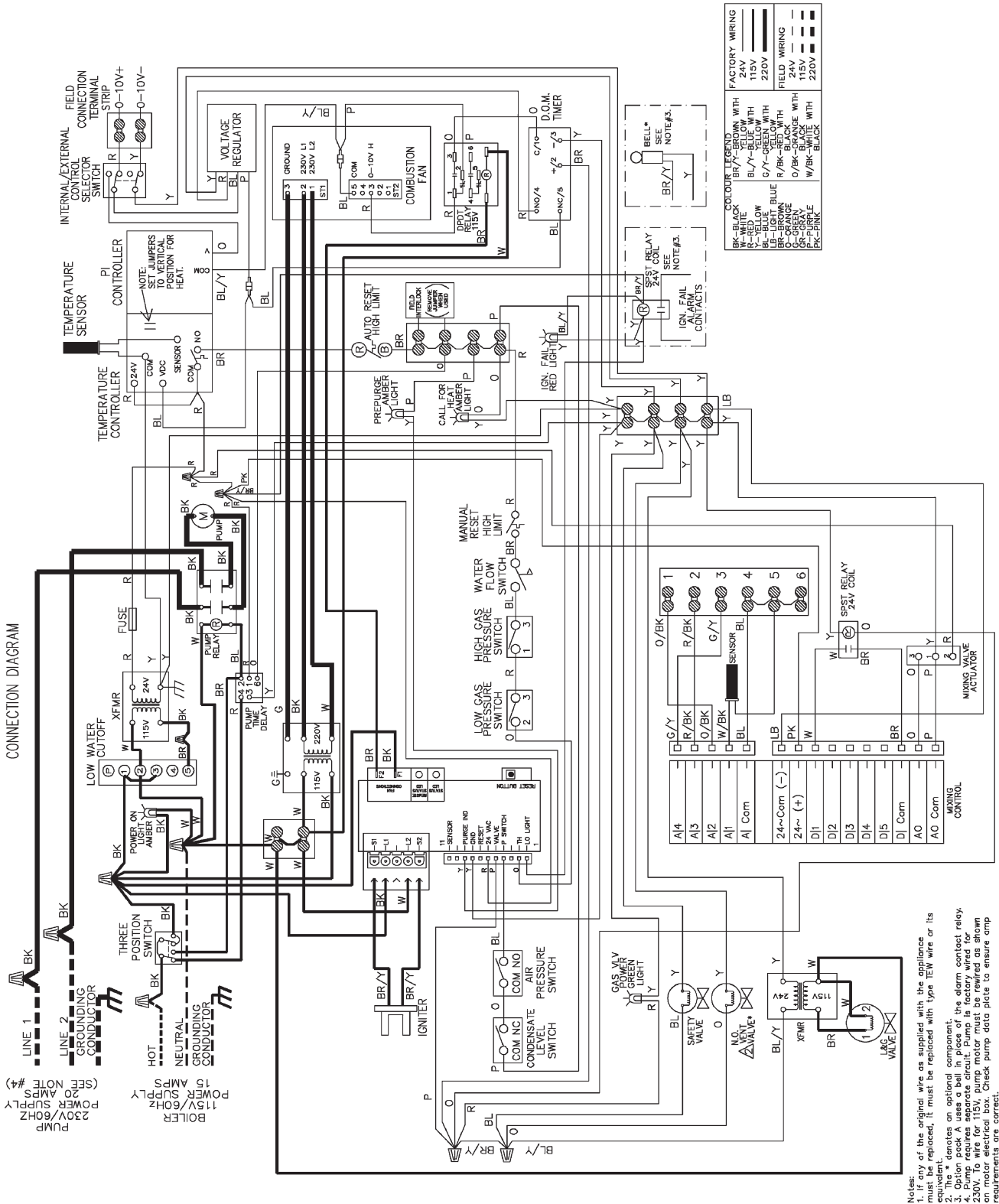

Figure 17 - Wiring Diagram, Model 1200, Standard and Codes A and F



Notes:
1. Necessary of the original wire as supplied with the appliance must be replaced, it must be replaced with type TEW wire or its equivalent.
2. The * denotes an optional component.
3. The alarm contact relay.
4. Pump requires separate circuit. Pump is factory wired for 230V. To wire for 115V, pump motor must be rewired as shown on motor electrical box. Check pump data plate to ensure amp requirements are correct.

Figure 18 - Wiring Diagram, Models 1600, 2000 and 2400, Standard and Codes A and F

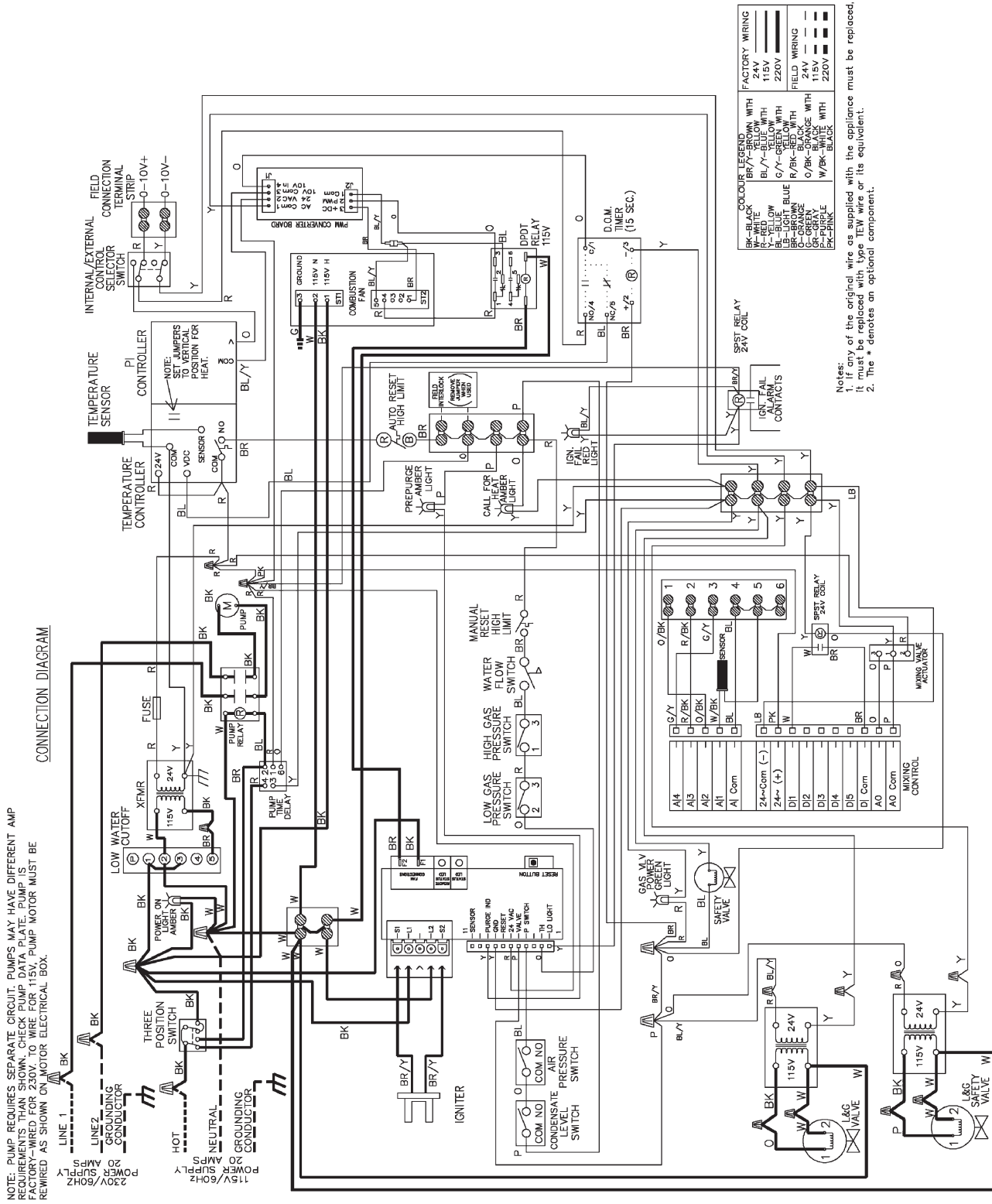

Figure 19 - Wiring Diagram, Model 1200, Code B

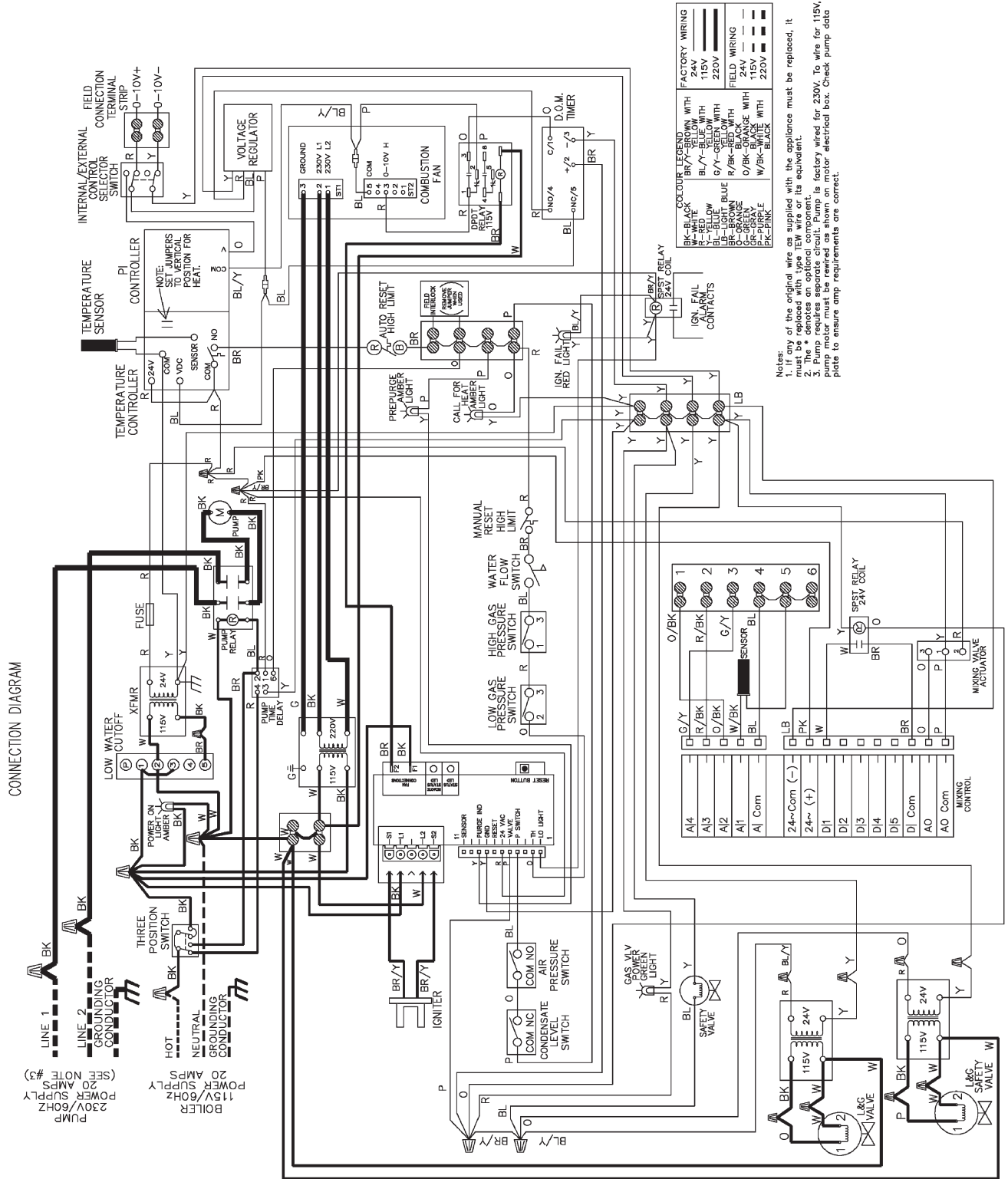

Figure 20 - Wiring Diagram, Models 1600, 2000 and 2400, Code B

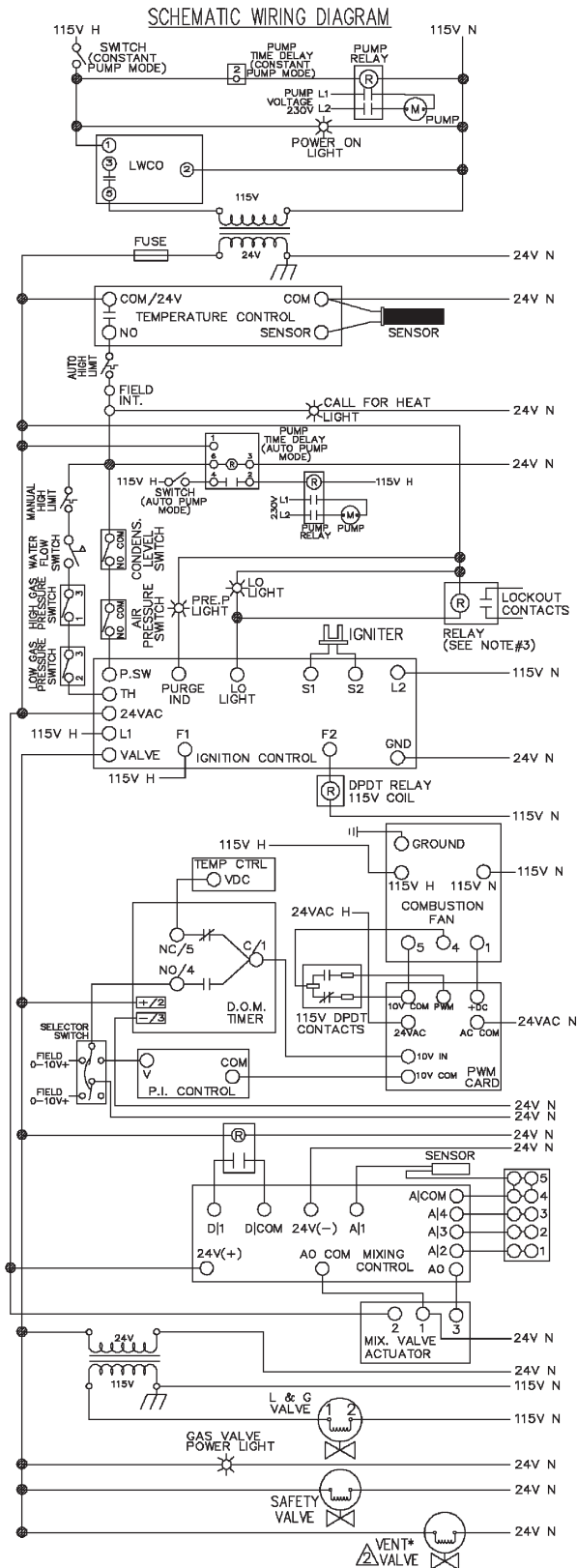

Figure 21 - Wiring Schematic, Model 1200, Standard and Codes A and F

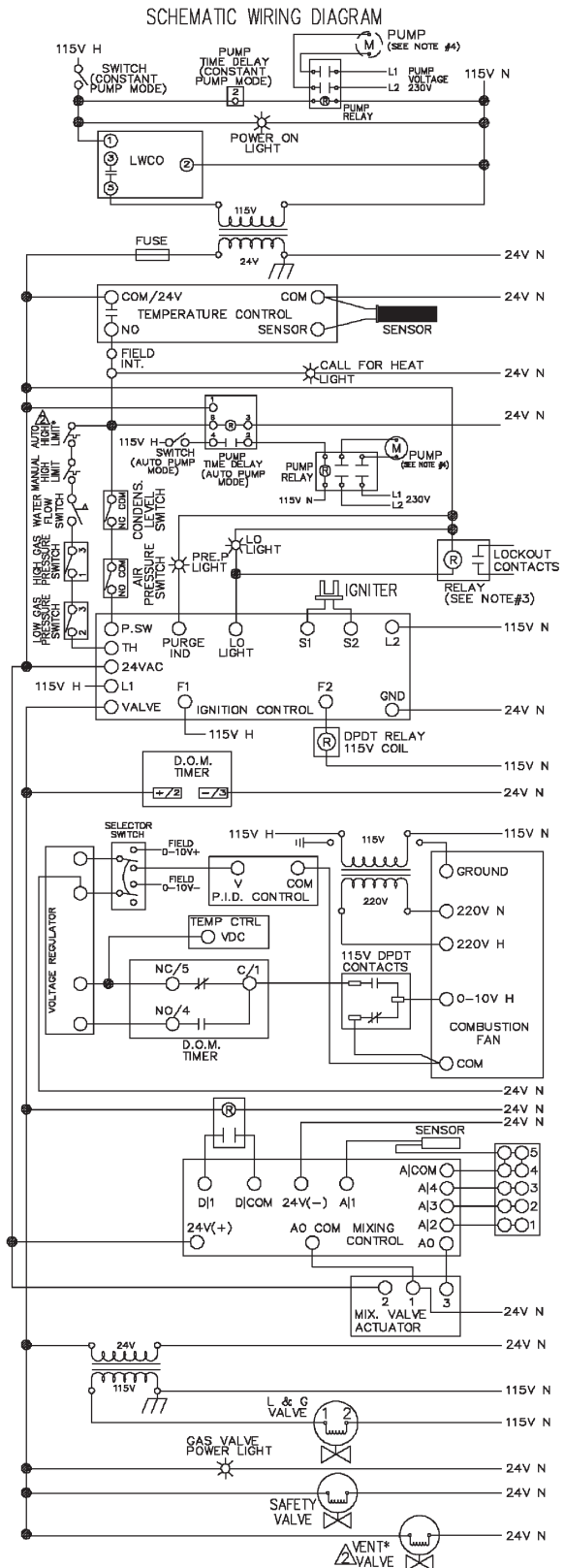

Figure 22 - Wiring Schematic, Models 1600, 2000 and 2400, Standard and Codes A and F

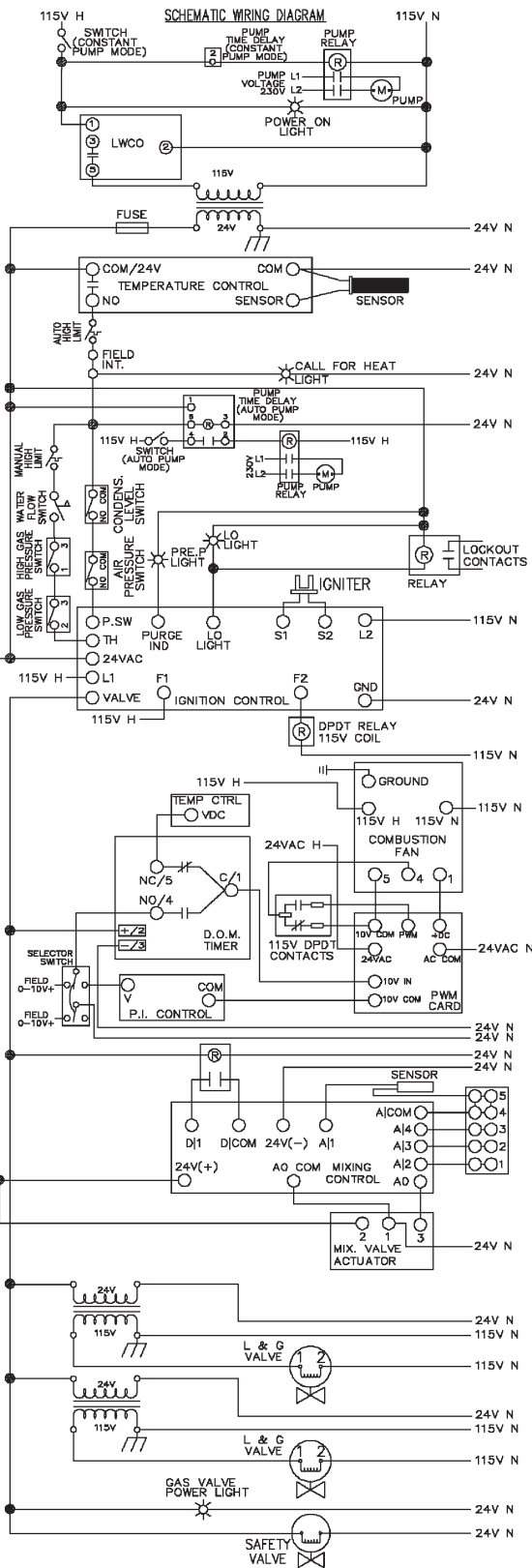

Figure 23 - Wiring Schematic, Model 1200, Code B

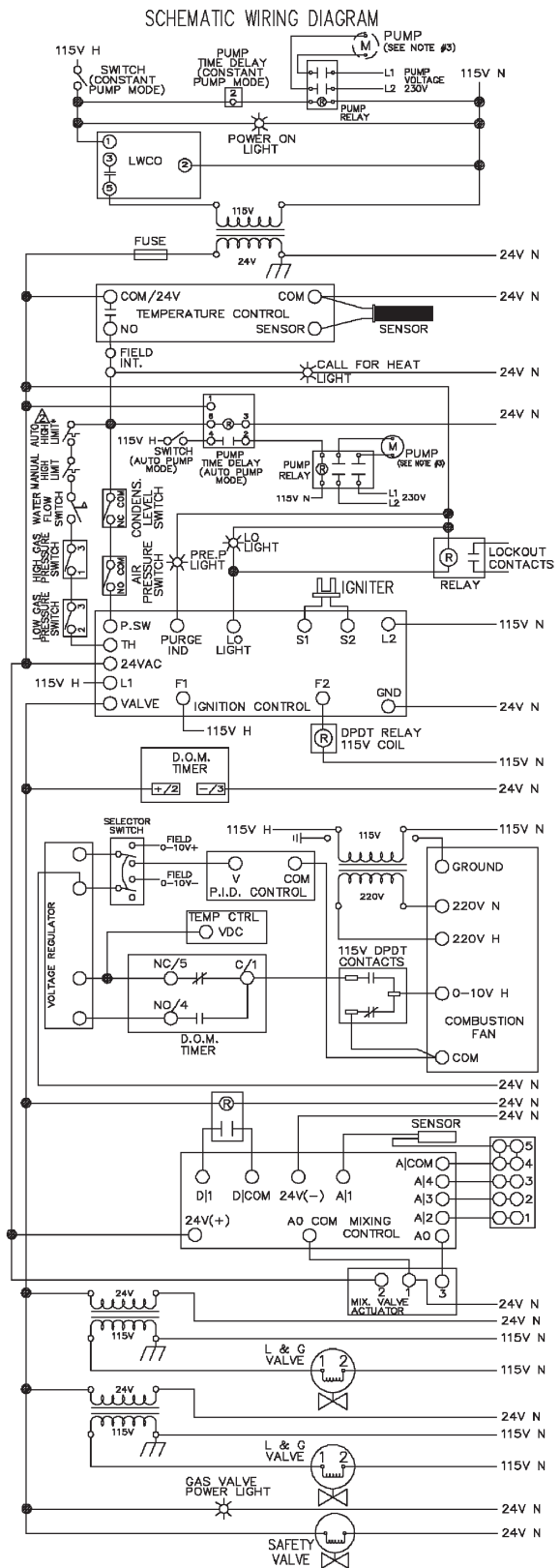

Figure 24 - Wiring Schematic, Models 1600, 2000 and 2400, Code B

Section 6

OPERATING INSTRUCTIONS

6.1 Filling the Boiler System

1. Ensure the system is fully connected. Close all bleeding devices and open make-up water valve. Allow system to fill slowly.
2. If make-up water pump is employed, adjust pressure switch on pumping system to provide a minimum of 12 psi (81.8 kPa) at the highest point in the heating loop.
3. If a water pressure regulator is provided on the make-up water line, adjust the pressure regulator to provide at least 12 psi (81.8 kPa) at the highest point in the heating loop.
4. Open bleeding devices on all radiation units at the high points in the piping throughout the system, unless automatic air bleeders are provided at such points.
Note that there is an air bleed (coin vent) located in the back of the unit, on top of the flue collector, to bleed air from the secondary (stainless steel) heat exchanger.
5. Run system circulating pump for a minimum of 30 minutes with the boiler shut off.
6. Open all strainers in the circulating system, check flow switch operation, and check for debris. If debris is present, clean out to ensure proper circulation.
7. Recheck all air bleeders as described in Step 4.
8. Check liquid level in expansion tank. With the system full of water and under normal operating pressure, the level of water in the expansion tank should not exceed $\frac{1}{4}$ of the total, with the balance filled with air.
9. Start up boiler according the procedure in this manual. Operate the entire system, including the pump, boiler, and radiation units for one (1) hour.
10. Recheck the water level in the expansion tank. If the water level exceeds $\frac{1}{4}$ of the volume of the expansion tank, open the tank drain, and drain to that level.
11. Shut down the entire system and vent all radiation units and high points in the system piping, as described in Step 4.
12. Close make-up water valve and check strainer in pressure reducing valve for sediment or debris from the make-up water line. Reopen make-up water valve.
13. Check gauge for correct water pressure and also check water level in the system. If the height indicated above the boiler insures that water is at the highest point in the circulating loop, then the system is ready for operation.

14. Refer to local codes and the make-up water valve manufacturer's instructions as to whether the make-up water valve should be left open or closed.
15. After placing the unit in operation, the ignition system safety shutoff device must be tested. First, shut off the manual gas valve, and call the unit for heat. Main gas terminals will be energized, attempting to light, for seven (7) seconds, and then will de-energize. The unit will go into lockout mode. Second, turn the power off, press the manual reset button on the ignition control, open the manual gas valve and allow the unit to light. While the unit is operating, close the manual gas valve and ensure that power to the main gas valve has been cut.
16. Within three (3) days of start-up, recheck all air bleeders and the expansion tank as described in Steps 4 and 8 above.

Important: The installer is responsible for identifying to the owner/operator the location of all emergency shutoff devices.

WARNING

Do not use this appliance if any part has been under water. Immediately call a qualified service technician to inspect the appliance and to replace any part of the control system and any gas control that may have been under water.

6.2 Operating the Burner and Set Up

The Rheos+ modulating appliance utilizes an advanced, state-of-the-art design. The setup must be checked before the unit is put in operation. Problems such as failure to start, rough ignition, strong exhaust odors, etc. can be due to improper setup. Damage to the boiler resulting from improper setup is not covered by the limited warranty.

REQUIRED TOOLS:

Differential pressure gauge capable of reading negative 0.01 inches W.C. (0.002kPa).

1. Using this manual, make sure the installation is complete and fully in compliance with the instructions.
2. Determine that the appliance and system are filled with water and all air has been bled from both. Open all valves.
3. Observe all warnings on the Operating Instructions label and turn on gas and electrical power to appliance.
4. There is a gas/air test panel to the left of the control panel, at the front of the unit (see Figures 25 and 32). Ensure that all four valves on the test panel are closed (see Figure 26).

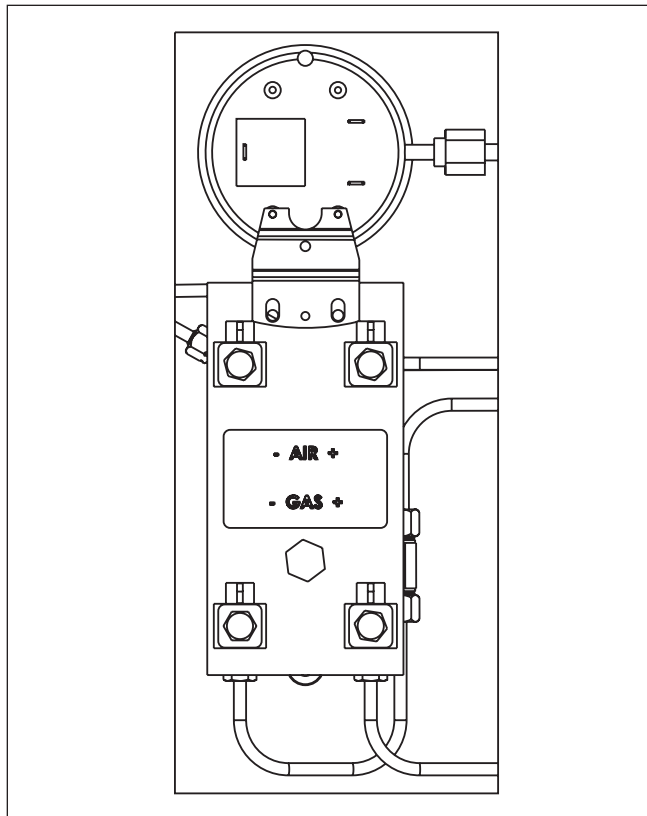

Figure 25 - Gas/Air Test Panel

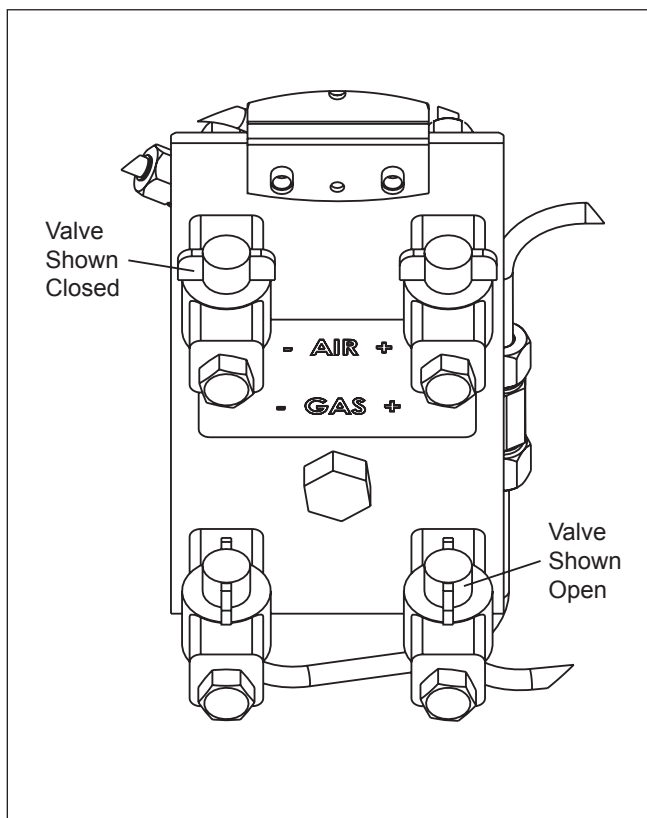

Figure 26 - Test Panel Valves

5. Remove the two plugs from the + and – ports of the air orifice taps, thread hose barbs into the 1/8" NPT connections, and attach the manometer pressure lines to the barbs. Be sure all connections are gas tight.
6. Switch on the appliance power switch located on the front of the unit.
7. The Rheos+ will enter the start sequence. The blower and pump come on for pre-purge, then the ignitor warm-up sequence starts and after all safety devices are verified, the gas valve opens. If ignition doesn't occur, check that there is proper gas supply. Wait 5 minutes and start the unit again.
8. Open air orifice test port valves. Check air orifice differential at full fire, and make note of the differential.
9. Switch the Rheos+ off.
10. Close air orifice valves, remove the barbs and replace the plugs. Make sure the connections are gas tight.
11. Remove the two plugs from the + and – ports of the gas orifice taps, thread hose barbs into the 1/8" NPT connections, and attach the manometer pressure lines to the barbs. Be sure all connections are gas tight.
12. Switch on the appliance power switch located on the front of the unit.
13. The Rheos+ will enter the start sequence. The blower and pump come on for pre-purge, then the ignitor warm-up sequence starts and after all safety devices are verified, the gas valve opens.
14. Open gas orifice test port valves. Check gas orifice differential at full fire, and make note of the differential.
15. Close gas orifice valves, remove the barbs and replace the plugs. Make sure the connections are gas tight.
16. If gas and air orifice differentials match what is shown in Table 7, and do not differ from each other by more than 0.1" w.c., the unit is properly set up. If not, consult the factory.
17. **After placing the appliance in operation, the Burner Safety Shutoff Device must be tested.** To test:
 - (a) Close gas shutoff valve with burner operating.
 - (b) The flame will go out and blower will continue to run for the post purge cycle. One additional attempt to light will follow including pre-purge, ignitor on, valve/flame on and post purge. Ignition will not occur as the gas is off. The ignition control will lockout, and will have to be reset before the unit will operate.

- (c) Open gas shutoff valve. Restart the appliance. The ignition sequence will start again and the burner will start. The appliance will return to its previous mode of operation.

⚠ Caution

Should any odor of gas be detected, or if the gas burner does not appear to be functioning in a normal manner, CLOSE MAIN SHUTOFF VALVE. Do not shut off switch. Contact your heating contractor, gas company, or factory representative.

Gas Type	Air Orifice Differential	Gas Orifice Differential
Natural	4.0 to 4.5" W.C. (1.0 to 1.1kPa)	4.0 to 4.5" W.C. (1.0 to 1.1kPa)
Propane	4.5 to 5.0" W.C. (1.1 to 1.2kPa)	4.5 to 5.0" W.C. (1.1 to 1.2kPa)

Note: Long runs of vent or combustion air piping may reduce the air and gas differential pressures. This is acceptable, as long as the air and gas pressure differentials are within 0.1" (0.025kPa) w.c. of each other.

Table 7 - Air and Gas Orifice Differentials at Full Fire

6.3 Shutting Down the Rheos+

1. Switch off the main electrical disconnect switch.
2. Close all manual gas valves.
3. If freezing is anticipated, drain the Rheos+ and be sure to also protect building piping from freezing.

This step to be performed by a qualified service person.

6.4 To Restart the Rheos+

If drained, follow Section 6.1 in this manual for proper filling and purging.

1. Switch off the main electrical disconnect switch.
2. Close all manual gas valves.
3. **WAIT FIVE (5) MINUTES.**
4. Set the aquastat or thermostat to its lowest setting.
5. Open all manual gas valves.
6. Reset all safety switches (pressure switch, manual reset high limit, etc).
7. Set the temperature controller to the desired temperature setting and switch on electrical power.
8. Burner will go through a prepurge period and ignitor warm-up period, followed by ignition.

Section 7 MAINTENANCE

⚠ WARNING

Disconnect all power to the appliance before attempting any service to the appliance. Contact with electricity can result in severe injury or death.

7.1 System Maintenance

1. Lubricate the system water-circulating pump, if required, per the instructions on the pump.
2. If a strainer is employed in a pressure reducing valve or the piping, clean it every six months.
3. Inspect the venting system for obstruction or leakage at least once a year. Periodically clean the screens in the vent terminal and combustion air terminal (when used).
4. Keep the appliance area clear and free from combustible materials, gasoline, and other flammable vapors and liquids.
5. If the appliance is not going to be used for extended periods in locations where freezing normally occurs, it should be isolated from the system and completely drained of all water.
6. Low water cutoffs, if installed, should be checked every 6 months. Float type low water cutoffs should be flushed periodically.
7. Inspect and clean the condensate collection and disposal system yearly.
8. When a means is provided to neutralize condensate, ensure that the condensate is being neutralized properly.
9. Inspect flue passages, and clean with brushes/ vacuums, if necessary. Sooting in flue passages indicates improper combustion. Determine the cause and correct.
10. Inspect the vent system and air intake system, and ensure that all joints are sealed properly. If joints need to be resealed, completely remove existing sealing material, and clean with alcohol. Apply new sealing material, and re-assemble.

7.2 Appliance Maintenance and Component Description

Only genuine LAARS replacement parts should be used.

⚠ Caution

Label all wires prior to disconnection when servicing controls. Wiring errors can cause improper and dangerous operation. Verify proper operation after servicing.

See Figures 27, 28 and 32 for location of gas train and control components.

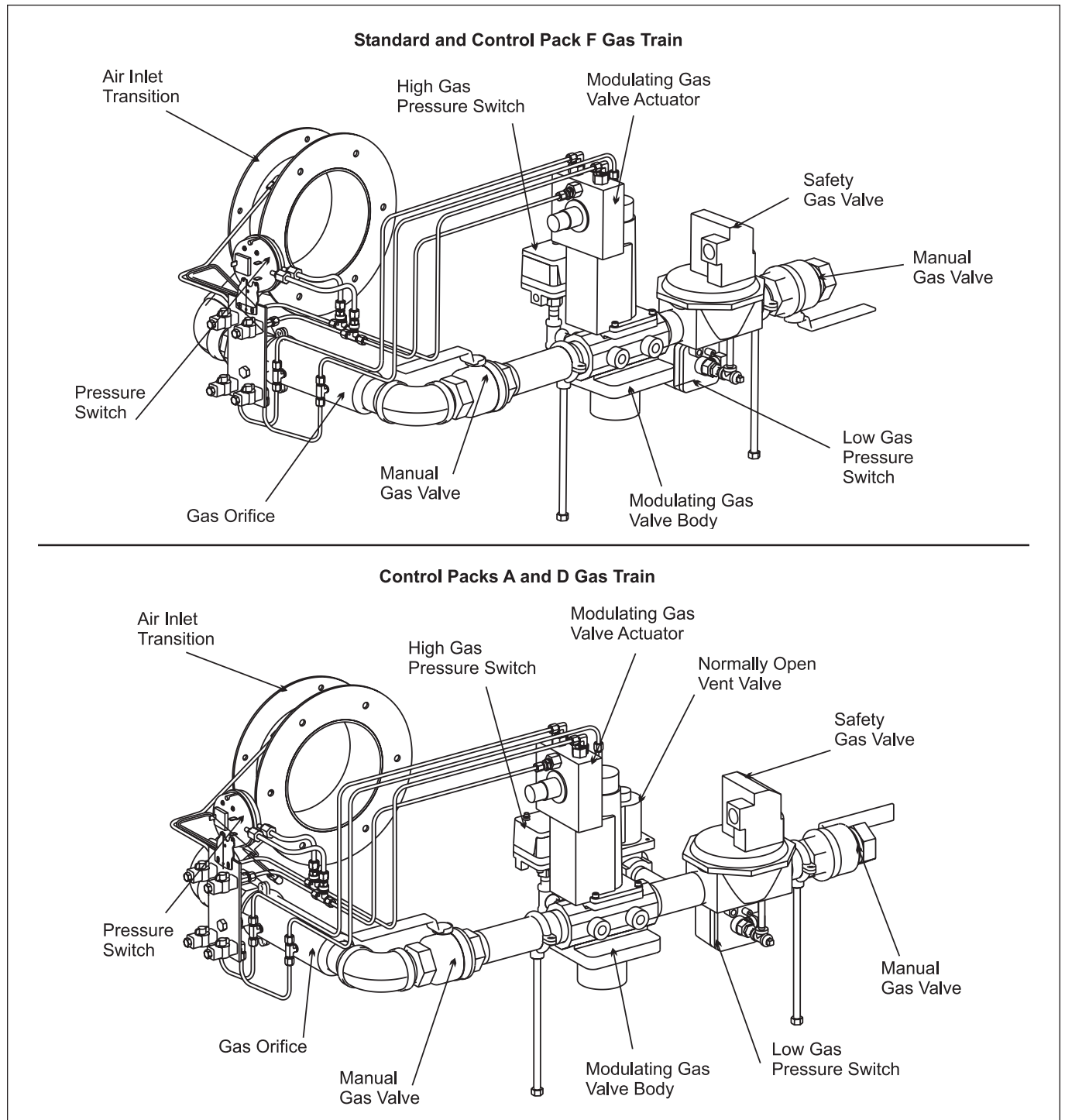

Figure 27 - Gas Trains

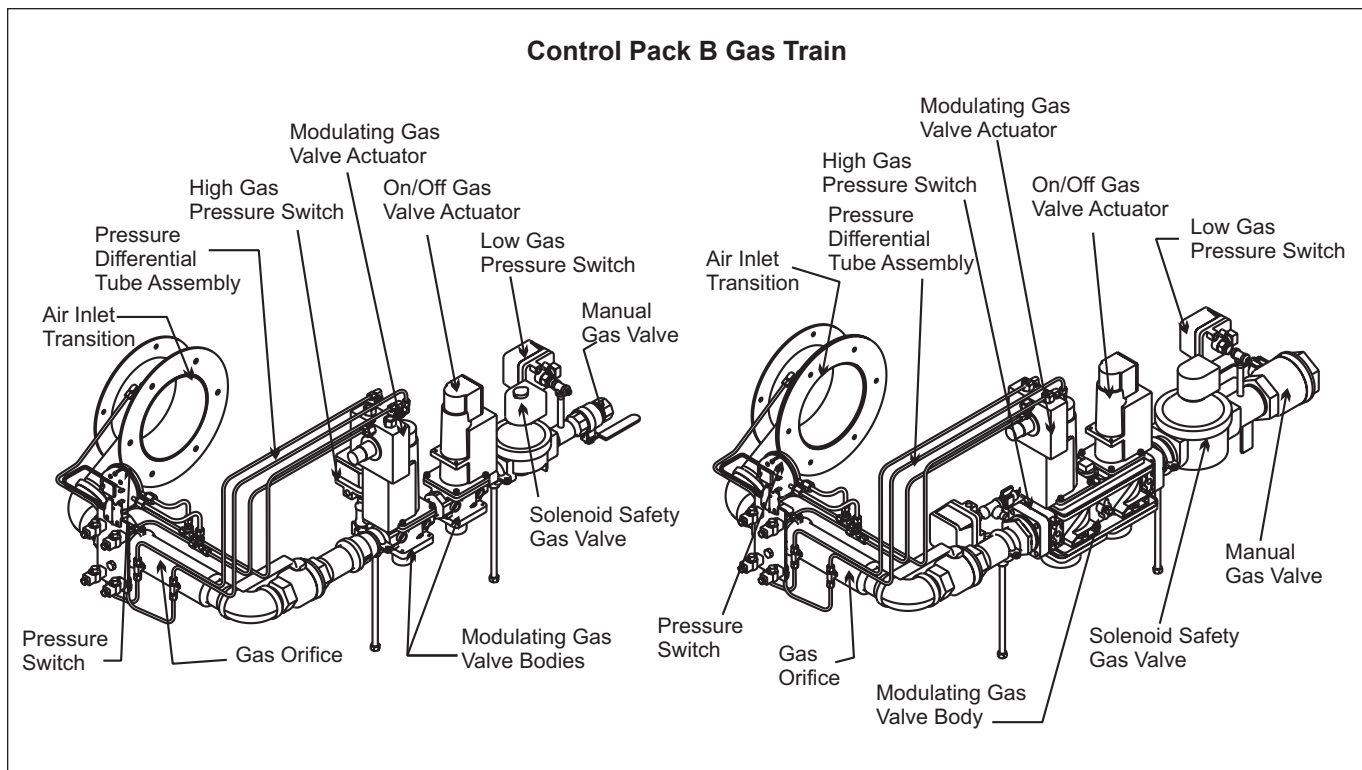

Figure 28 - Gas Trains

The gas and electric controls on the appliance are engineered for long life and dependable operation, but the safety of the equipment depends on their proper functioning. It is strongly recommended that a qualified service technician inspect the basic items listed below every year.

- a. Ignition control
- b. Water temperature control
- c. Automatic gas valve
- d. Pressure switches
- e. Blower
- f. Mixing control

7.2.1 Burner

Check the burner for debris. Remove the fan assembly to access the burner. Remove the 6 nuts, which hold the burner in place. Pull burner up and out. Clean burner, if necessary, by blowing compressed air from the outside of the burner into the center of the burner, and wipe the inside of the burner clean with glass cleaner. A dirty burner may be an indication of improper combustion or dirty combustion air. Determine the cause, and correct. Always replace the burner gasket when replacing the burner.

7.2.2 Filter

The filter used in the Rheos+ is washable with an 83% arrestance. Since the filter is washable, it will only need replacement in very rare cases. If filter replacement is needed, it should only be replaced with

factory parts. To access the filter, remove the unit's front panel. Disengage latch on top of filter box and remove the filter box cover. Inspect the air filter. If there is debris on the air filter, remove it from the filter box, and wash it with mild soap and water. Ensure that the filter is completely dry before re-installing, in reverse order.

7.2.3 Modulating Gas Valve

The modulating gas valve consists of a valve body and a pressure regulating electro-hydraulic actuator. It provides the air/gas ratio control for the unit. It is designed to operate with supply pressures of 4-13 inches w.c. (1.0 to 3.2 kPa).

To remove the valve actuator, shut off 120-volt power and the gas shutoff valve. Remove the front panel from the unit. **Label the four pressure tubes that are connected to the valve actuator, to ensure that they will be replaced correctly and disconnect them from the actuator.** Remove the four tubes from the barb connectors. Disconnect the 120-volt wires from the actuator. Remove the valve actuator by taking out the four screws, and pulling the actuator out. Re-install in reverse order. Turn on gas shutoff valve and 120 volt power and check appliance operation and tightness of gas valve connections.

The gas valve body will rarely have to be removed. If there is a valve problem, and it has been determined the actuator is working properly, the gas valve body may need to be replaced. To remove the gas valve body, shut off 120-volt power and the gas

shutoff valve. Remove the front and right-side panels from the unit. Disconnect the union between the valve body and the blower. **Label the four pressure tubes that are connected to the valve actuator, to ensure that they will be replaced correctly.** Remove the valve actuator, per the instructions above. Unscrew the valve body from the gas train. After the valve has been removed, replace with a new valve in the reverse order. Turn on gas shutoff valve and 120 volt power and check appliance operation and tightness of gas valve connections.

7.2.4 Safety Gas Valve

The safety gas valve is a 24-volt diaphragm valve. It is designed to operate with supply pressures of 4-13 inches w.c. (1.0 to 3.2 kPa). To remove the gas valve, shut off 120-volt power. Shut off the main gas supply to the unit. Disconnect the gas supply piping from the back of the unit. Disconnect the electrical wires from the valve, and unscrew the gas valve from the gas train. Re-assemble in reverse order. A bleed line from the diaphragm type automatic valve shall be vented per local code requirements.

7.2.5 Manual Reset High Limit Control

The high limit switch is manual reset switch with an adjustable set point, up to 240°F (116°C) on boiler models and 200°F (93°C) water heater models. To replace the switch, shut off the 120-volt power to the appliance. Remove the cover from the switch to access the mounting screws. Remove the screws, and pull the switch off the control panel. Replace in reverse order.

7.2.6 Temperature Control

The temperature control consists of an adjustable electronic control and digital display module. To replace the control or the display, shut off the 120-volt power to the appliance. Remove the cover from the control panel, and remove the screws from the DIN rail clip, to which the controls are mounted. Pull the electrical connector from the controller. Slide the controllers from the DIN rail clip. Replace in reverse order.

7.2.7 Auto Reset Temperature Limit

The auto reset temperature limit has a 200°F (93°C) setting. The is mounted directly onto the Rheos+ header, on the inlet to the copper coil. It senses the inlet water temperature to copper coil, and guards against a malfunctioning mixing system. To replace the switch, shut off the 120-volt power to the appliance. Remove the cover from the switch to access the mounting screws. Remove the screws, and pull the switch off the control panel. Replace in reverse order.

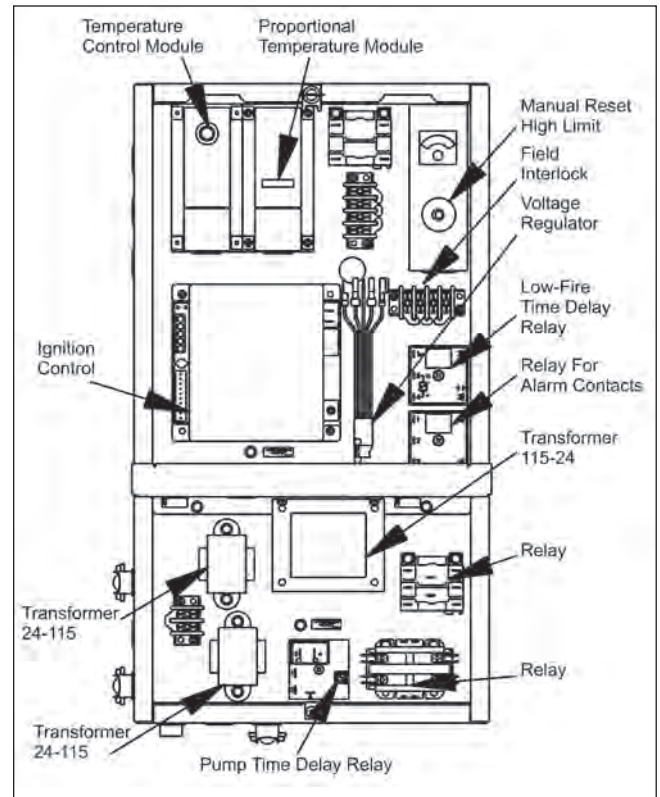

Figure 29 - Control Panel

7.2.8 Mixing Control

The FX05 mixing control is the device that controls the position of the mixing valve system. This control is factory set, and must not be adjusted, except for the °F or °C choice. To remove the control, unplug the wires from the back, push on the tabs to slide the clamping mechanism off, and pull the controller out through the front of the panel. Replace in reverse order.

7.2.9 Mixing Valves

There are two 2-way mixing valves that are linked and connected to a valve actuator to create the 3-way mixing system. To remove the upper right valve, remove the actuator and then remove the 2 bolts that connect the sheet metal to the valve. Remove the linkage from the arm that is welded to the actuator. Remove the four bolts on the valve, and slide the valve out. To remove the lower left valve, remove the 2 bolts that connect the sheet metal to the valve. Remove the linkage from the arm that is welded to the actuator. Remove the four bolts on the valve, and slide the valve out. Reassemble in reverse order.

7.2.10 Mixing Actuator

The mixing actuator connects to both mixing valves and takes its signal from the mixing control to properly set the valves to protect the copper heat exchanger. To remove the actuator, remove the screw on the front to take the cover off. Disconnect the wires. Take the 2 nuts off the U-bolt, to move the linkage to the side, out of the way. Slide the actuator out. Reassemble in reverse order.

7.2.11 Ignition Control

The ignition control ensures the proved interrupted-type ignition system. It controls the hot surface ignitor and proves that the flame signal is appropriate for powering the gas valves. It also controls the blower's pre-purge and post-purge. To replace the control, shut off the 120-volt power to the appliance. Remove the cover from the control panel. Remove the electrical connectors from the ignition control. Take out the controller's mounting screws, and pull the controller out. Replace in reverse order.

7.2.12 Ignitor / Flame Sensor Assembly

The ignitor is a 110v "hot surface" type. It is energized whenever there is a call for heat and switched off when ignition is established and the flame has been sensed. Ignitors with an ohms resistance over 80 ohms (tested after the ignitor has been allowed to cool to room temperature) should be replaced. To replace the ignitor, shut off the 120-volt power to the appliance, disconnect the Molex connector, remove the two mounting screws on the ignitor flange, and pull the ignitor out. Always install a new ignitor gasket with the replacement ignitor.

Caution

Ignitor gets hot and can cause burns or injury.

7.2.13 Transformers

There are various transformers used on the Rheos+ units. Be sure to replace the transformers with factory parts. These transformers are not capable of supplying control voltage for external devices such as zone valves, which must have their own separate power supply. Should a transformer need replacing, shut off the 120-volt power. Unplug the transformer wires, remove the mounting screws and remove the transformer. Replace transformer in the reverse order.

7.2.14 Blower

The combustion air blower is a high-pressure centrifugal blower with a variable speed motor. The speed of the motor is determined by the control logic, and the 120-volt current remains on to the blower at all times. If a blower change is required, turn off the 120-volt power and gas supply to the unit. Take the front

panel, the two side access panels, and the top jacket panel off. (If there is enough clearance on the side, the top may not have to be removed.) Disconnect the gas union between the blower and gas valves. Disconnect the filter box assembly (at the air transition) from the blower (six 8 mm bolts). Disconnect the two Molex electrical connectors from the top right of the blower. Remove the four nuts from the blower flange, and pull the blower out. Replace blower in reverse order, ensuring that all joints are made correctly and sealed. After replacement, ensure that the unit operates properly, by following the set-up procedure in this manual.

7.2.15 Flow Switch

The Rheos+ uses a paddle-type flow switch to ensure that the unit has water flow before ignition is allowed.

7.2.16 Heat Exchanger Coils

Black carbon soot buildup on the external surfaces of the copper heat exchanger is caused by one or more of the following; incomplete combustion, combustion air problems, venting problems and heater short cycling. Soot buildup or other debris on the heat exchanger may restrict the flue passages.

If black carbon soot buildup on the copper exchanger is suspected, disconnect electrical supply to the unit, and turn off the gas supply by closing the manual gas valve on the unit. Access the heat exchanger through the side access panels, and inspect the finned copper tubing using a flashlight. If there is a buildup of black carbon soot or other debris on the heat exchanger, clean per the following:

Caution

Black carbon soot buildup on a dirty heat exchanger can be ignited by a random spark or flame. To prevent this from happening, dampen the soot deposits with a wet brush or fine water spray before servicing the heat exchanger.

1. Disconnect the electrical supply to the unit.
2. Turn off the gas supply by closing the manual gas valve on the heater.
3. Disconnect and remove the wires, conduit and sensors from all components that are attached to the inlet/outlet header.
4. Isolate the heat exchanger from the water supply.
5. Drain the heat exchanger from the drain located on the bottom of the heat exchanger.
6. Disconnect the header flanges from the inlet and outlet.
7. Remove the heat exchanger from the unit.
NOTE: The heat exchangers are heavy and may require two people to remove to avoid personal injury.

8. Clean the heat exchanger: A light accumulation of soot or corrosion on the outside of the heat exchanger can be easily removed. Use a wire brush to remove loose soot and scale from the heat exchanger. Do not use water or compressed air for cleaning.
9. NOTE: While the heat exchanger is out of the unit, inspect the firewall refractory insulation blocks for cracks, wear and breakage. Replace if necessary.
10. Inspect the inside of the copper tubes for scale buildup. Scale can build up on the inner surface of the heat exchanger tubes, which can restrict water flow. If the tubes show signs of scaling, clean the internal surface. LAARS offers a tube cleaning kit part number R2000700.
11. Reassemble in the reverse order.

If heat exchanger removal is necessary, consult the factory for instructions.

NOTE: The Warranty does not cover damage caused by lack of required maintenance, lack of water flow, or improper operating practices.

The condensing (stainless steel) heat exchanger is not in the firing chamber, so it will not experience sooting. If there is fouling on the stainless steel heat exchanger, or if it needs to be changed, contact the factory.

7.2.17 Normally Open Vent Valve

Some Rheos+ models provide a normally open vent valve for installations with IRI code requirements. The valve opens when power is removed from the safety valves. And the valve closes when the safety valves are powered. See Section 3.1 item #4 for installation instructions.

7.2.18 Motorized Safety Valve

Control packs B and E have an additional motorized safety valve. This valve is powered open at the same time as the safety valve. To remove the valve actuator, shut off the 120V power and the gas shutoff valve. Remove the right side, or front panel. Disconnect the 120V wires from the actuator. Remove the valve actuator by taking out the four screws, and pulling the actuator out. Re-install in reverse order. Turn on gas shutoff valve and 120V power and check appliance operation and tightness of gas valve connections.

The gas valve body will rarely have to be removed. If there is a valve problem, and it has been determined the actuator is working properly, the gas valve body may need to be replaced. To remove the gas valve body, shut off 120V power and the gas shutoff valve. Remove the right side and front panels. Remove the valve actuator. Unscrew the valve body from the gas train. After the valve has been removed, replace with a new valve in reverse order. Turn on gas

shutoff valve and 120V power and check appliance operation and tightness of gas valve connections.

7.2.19 Gas Pressure Switches

The high and low gas pressure switches are 24V manual reset switches that act to cut power to the gas valves if the gas pressure is too low or too high for proper operation. The gas pressure switches used are integrally vent limited, and do not require venting to atmosphere. To remove a switch, remove the screw on the plastic housing and pull the clear cover off. Disconnect the two wires from the screw terminals. Twist the switch off the pipe nipple. Reassemble in reverse order. For natural gas, set the low gas pressure switch to 3" w.c. For propane, set the low gas pressure switch to 5" w.c. For natural and propane, set the high gas pressure switch to 14" .

Section 8 TROUBLESHOOTING

8.1 Sequence of Operation

The Rheos+ appliance is a cold start appliance that should start only on a call for heat from a tank aquastat, room thermostat, zone valve end switch or other space temperature control device.

1. Upon a call for heat,
 - (a) The internal pump will start.
 - (b) The blower will begin a 15 second pre-purge.
2. Following the prepurge cycle the hot surface ignitor will heat and will begin a 7 second trial for ignition. The unit is allowed three attempts for ignition.
3. The gas valve will then be energized and low-fire (50% of full fire) ignition will occur. The unit will remain in a low-fire start-up period for 15 seconds.
4. After the low-fire start time is over, the unit will be in normal operation firing rate and will modulate based on the heating load via the temperature controller settings and readings.
5. The mixing system control will sense the water temperature entering the copper heat exchanger, and will change the positions of the mixing valves to divert enough hot water from the copper heat exchanger outlet back to its inlet to keep the inlet at a minimum 140°F (60°C). Therefore, when the return water temperature is 140°F (60°C) or lower, the outlet temperature will be 160-165°F (71-74°C). With return temperatures greater than 140°F (60°C), the temperature rise across the Rheos+ is 20-25°F (11-14°C), when the Rheos+ is at high firing rate.

6. When the call for heat is complete, or the unit reaches its setpoint temperature, the gas valve will close, and the fan will continue to run for its 30 second post-purge. If a pump time delay is used, the pump will continue to run for the specified amount of time (adjustable from 0.1 to 10 minutes).

8.2 Resolving Lockouts

There are many causes of lockouts. The four most common causes are: (1) inadequate gas supply, (2) poor combustion, (3) ignitor failure (4) combustion air.

1. Inadequate gas supply: Before proceeding, ensure that the gas supply has not been shutoff or the LP tank (LP boilers) is not empty. Then, restart the boiler and observe the operational cycle. After the pre-purge time, the unit should light. If it does not, consult the factory.
2. Poor Combustion: Poor combustion should be suspected if there is a strong flue gas odor. The odor may result from an improper gas/air ratio (high or low O₂ or CO₂). If an improper gas/air ratio is suspected, consult the factory.
3. Ignitor failure: If the boiler goes through a normal start cycle but combustion does not occur, ignitor failure should be suspected. Check the ignitor by unplugging the ignitor plug and measuring the ignitor resistance. It should be 50-80 (Ω) ohms. If the resistance is not 50-80 ohms (Ω), replace the ignitor. If the resistance is correct, reset the boiler and check for 120 VAC at the ignitor plug during the start cycle. If there is no voltage, replace the faulty ignitor wire harness.
4. Inadequate combustion air: If the boiler goes through a normal ignition cycle, and shuts off after the blower ramps up to full speed, an abnormal restriction in the air intake or exhaust system should be suspected. Check the air filter for buildup of debris and clean filter if necessary. Inspect all exhaust venting and intake venting for blockages. Remove any blockages and inspect and replace any damaged vent sections. If the unit still continues to lockout after igniting, consult the factory.

Once the reason for the lockout has been identified and resolved you can reset the unit by pressing the manual reset button (see Detail A in Figure 30, Control Panel).

8.3 Delayed Ignition - Possible Causes

8.3.1 High Lockup Pressure (LP Appliances) - Occurs on Start-up

High lock up pressure is the most common cause of delayed ignitions on LP fueled appliances. It may result from an improper second stage regulator selection or from a faulty regulator.

Lock up can be detected by measuring the gas supply pressure to the appliance at the inlet pressure port on the gas valve. The gas supply to the appliance must be shut off before making any connections. To check: use a water manometer or pressure gauge with a scale reading of at least 25 in. W.C. or 15 oz/in². (6.2kPa). Attach the manometer to the gas valve inlet pressure port. Turn on the gas supply. The Rheos+ appliance is designed to operate with supply pressures of 4-13 in. W.C. (2.3 - 7.5 oz/ in²) (1.0-3.2kPa). If the supply pressure exceeds 13 in. W.C. (7.5 oz/ in²) (3.2kPa) (with the appliance off) it is possible that this may be the cause of the delayed ignitions and the inlet pressure must be reset to between 4-13 in. W.C. (2.3 - 7.5 oz/in²) (0.1-3.2kPa). Restart the appliance and then switch it off. If the inlet gas pressure exceeds 13 in. W.C. (7.5 oz/ in²) (3.2kPa) after the appliance is switched off, correct the lock up problem.

8.3.2 Gas Valve Regulation

Gas valve regulation problems can also cause delayed ignitions. If gas valve regulation problems are suspected, consult the factory. Do not attempt field adjustment or repair.

8.3.3 Defective Burner - Occurs on Startup or at Burner Shutdown

A defective burner can cause a delayed ignition. If the gas supply pressure is proper, and the gas valve is functioning properly, the burner should be inspected. There should be no distortion or perforations in the burner. Replace if indicated.

8.4 Short Cycling — Boiler

Because the Rheos+ is a modulating boiler, and its input will decrease when there is a reduction in heating load, short cycling is greatly reduced. If the heating load drops below the minimum input of the boiler for an extended period, the boiler will have a tendency to short cycle. This can be a symptom of improper control strategy or setpoints, or a load distribution problem. See Section 5.5 regarding controller setup. Contact your LAARS representative to discuss possible remedies.

8.5 Short Cycling — Water Heater

Short cycling will generally occur only in combination space heating and water heating applications when the water heater is operating in the space-heating mode. Because the Rheos+ is a modulating water heater and its input will reduce when there is a reduction in heating load, short cycling is greatly reduced. If the heating load drops below the minimum input of the water heater for an extended period, the water heater will have a tendency to short cycle. If short cycling is frequently experienced, regardless of the control's attempt to limit it, the heating load should be redistributed to control it. See Section 5.5 regarding controller setup.

If short cycling occurs in a water heater application, it is probably caused by undersized piping between the water heater and the storage tank or by some other factor that restricts proper water flow through the water heater. The cause should be determined and corrected.

8.6 High Gas Consumption

Appliances operating with an improper air/fuel ratio are very inefficient and consequently, have very high gas consumption. Because efficiency is high when the CO_2 is high (or O_2 is low), appliances operating with low CO_2 or high O_2 (especially LP appliances) consume more gas. Adjust the CO_2 or O_2 for optimum efficiency. If no combustion analyzing equipment (CO_2 or O_2) is available then a proper adjustment of the air/fuel ratio (CO_2 or O_2) can not be accomplished. However, by briefly sniffing the flue gases it is possible to determine if the CO_2 or O_2 is within the proper range. No significant flue gas odor should be detected when combustion is proper. A strong piercing smell indicates poor combustion and generally a lean mixture - low CO_2 or high O_2 . The CO_2 should be 8 to 9% at all firing rates. Do not attempt to correct combustion. Contact factory if the CO_2 is not within this range.

Section 9

REPLACEMENT PARTS

Only genuine LAARS replacement parts should be used.

9.1 General Information

To order or purchase parts for the LAARS Rheos+, contact your nearest LAARS dealer or distributor. If they cannot supply you with what you need, contact Customer Service (see back cover for address, telephone and fax numbers).

9.2 Parts List

COMBUSTION COMPONENTS

See *Figure 30*

	1200	1600	2000	2400
2 Base assembly	24A1200	24A1200	24A1200	24A1200
3 Panel, top, combustion chamber	24B2600	24B2600	24B2600	24B2600
4 Panel, bottom, combustion chamber	24A2400	24A2400	24A2400	24A2400
5 Panel, left, combustion chamber	24A2100	24A2100	24A2100	24A2100
6 Panel, right, combustion chamber	24A2200	24A2200	24A2200	24A2200
7 Panel, access, combustion chamber	24B2004	24B2004	24B2004	24B2004
8 Support, front, fan transition	24B2010	24B2010	24B2010	24B2010
9 Support, rear, fan transition	24B2009	24B2009	24B2009	24B2009
10 Hardware kit, Combustion Chamber/Condenser	R2026800	R2026800	R2026800	R2026800
11 Burner	L2012100	L2012000	L2011900	L2011800
12 Burner Gasket	S2009700	S2009700	S2009700	S2009700
13 Tile kit (top & bottom of heat exchanger w/top insulation)	R2002500	R2002500	R2002500	R2002500
14 Tile support with rods	12B2700	16B2700	20B2700	24B2700
15 Tile support protective liner	12B2005	12B2005	12B2005	24B2005
16 Panel, Divider, Condenser	24A2025	24A2025	24A2025	24A2025
17 Diverter, Air Flow, Condenser	24A2011	24A2011	24A2011	24A2011
18 Cover, Flue Transition	24A2300	24A2300	24A2300	24A2300
19 Clamping Bar, Side/Top, Flue Transition	24B2012	24B2012	24B2012	24B2012
20 Clamping Bar, Short, Flue Transition	24A2014	24A2014	24A2014	24A2014
21 Clamping Bar, Long, Flue Transition	24A2013	24A2013	24A2013	24A2013
22 Heat Exchanger, Condensing	S2014400	S2014400	S2014300	S2014300
24 Heat exchanger assembly, copper	R2013300	R2017100	R2017200	R2003100
24 Heat exchanger assembly, cupro-nickel	R2013301	R2017101	R2017201	R2003101
25 Baffle, Flue	12A2011	not used	not used	not used
29 Cable, Securement, Pump/Motor	24A9003	24A9003	24A9003	24A9003
30 Pressure Switch, Differential	E2312400	E2312400	E2312400	E2312400

GAS TRAIN / COMBUSTION AIR COMPONENTS

See *Figures 31 and 32*

	1200	1600	2000	2400
35 Gas train assembly, standard, Nat	12B6000	16B6000	20B6000	24B6000
35 Gas train assembly, standard, LP	12B6020	16B6020	20B6020	24B6020
35 Gas train assembly, control pack A, Nat	12B6400	16B6400	20B6400	24B6400
35 Gas train assembly, control pack A, LP	12B6420	16B6420	20B6420	24B6420
35 Gas train assembly, control pack B and E, Nat	12B6500	16B6500	20B6500	24B6500
35 Gas train assembly, control pack B and E, LP	12B6520	16B6520	20B6520	24B6520
36 Gas valve, safety	V2015800	V2015700	V2015700	V2015700
37 Gas valve, solenoid safety, for control packs B & E	V2014300	V2014400	V2014400	V2014400
38 Gas valve, mod valve actuator	V2015400	V2015400	V2015400	V2015400
39 Gas valve, mod valve body	V2015900	V2015900	not used	V2015500
39 Gas valve, mod valve body, size 2000, Nat	not used	not used	V2015500	not used
39 Gas valve, mod valve body, size 2000, LP	not used	not used	V2015900	not used
40 Gas valve, mod complete (body and actuator)	R2011500	R2011500	not used	R2003600
40 Gas valve, mod complete (body and actuator) size 2000, Nat	not used	not used	R2003600	not used
40 Gas valve, mod complete (body and actuator) size 2000, LP	not used	not used	R2011500	not used
41 Gas valve, manual (Primary)	V2003000	V2003200	V2003200	V2003200
41 Gas valve, manual (Secondary)	V2003000	V2003000	V2003200	V2003200
41 Gas valve, manual (Primary, Control Pack B & E)	V2003200	V2003200	V2003200	V2003300
42 Double valve body / Actuator	not used	not used	R2019600	R2019600
43 Double valve body	not used	not used	V2016500	V2016500
44 On/Off Actuator	V2016600	V2016600	V2016600	V2016600
45 Normally open vent valve	V2000100	V2000100	V2000100	V2000100
46 Gas orifice kit (orifice in holder), Nat	12B6200	16B6200	20B6200	24B6200
46 Gas orifice kit (orifice in holder), LP	12B6220	16B6220	20B6220	24B6220
47 Gas orifice, Nat	P2035500	P2042700	P2042800	P2034300
47 Gas orifice, LP	P2041500	P2043200	P2043300	P2038300
48 Pressure switch, high gas	E0023300	E0023300	E0023300	E0023300
49 Pressure switch, low gas	E0023500	E0023500	E0023500	E0023500

50	Tubing/Fittings (gas train repair kit)	R2020700	R2020700	R2020700	R2020700
51	Air filter box assembly (with gasket and hardware) Nat	12B5000	16B5000	20B5000	24B5000
51	Air filter box assembly (with gasket and hardware) LP	12B5020	16B5020	20B5020	24B5020
52	Air filter	A2108300	A2108300	A2108300	A2108300
53	Gasket kit, air filter	R2004600	R2004600	R2004600	R2004600
54	Air filter box cover	24B5300	24B5300	24B5300	24B5300
55	Air filter felt gasket	S2010800	S2010800	S2010800	S2010800
56	Air filter air inlet vent w / gasket	12B5001	24B5001	24B5001	24B5001
57	Blower	A2108500	A2108400	A2108400	A2108400
58	Blower gasket kit	R2012200	R2005000	R2005000	R2005000
59	Air orifice, Nat	12B5108	16B5108	20B5108	24B5108
60	Air orifice strip, LP	not used	not used	24B5128	24B5128
61	Air orifice, LP	12B5128	16B5128	20B5108	24B5108
62	Air restrictor, LP	not used	16B5221	20B5221	not used
63	Air transition (filter box to blower)	12B6100	24B6100	24B6100	24B6100
64	Blower adapter transition	12B5201	not used	not used	not used
65	Ignitor kit (with gasket)	RW2002300	RW2002300	RW2002300	RW2002300
66	Sight glass	F0044800	F0044800	F0044800	F0044800
67	Pressure switch, air	E2312300	E2312300	E2312300	E2312300

ELECTRICAL COMPONENTS*See Figure 33*

	1200	1600	2000	2400
70	Transformer, 115/24V, 80VA	30-280	30-280	30-280
70	Transformer, 115/24V, 150VA (Control pack B & E only)	E2310400	E2310400	E2310400
71	Transformer, 115/230V step up	-	R2005400	R2005400
72	Transformer, 24/115 step up	E2306000	E2306000	E2306000
73	Fuse kit, 2 Amp, 5 pack (not shown)	RE2043600	RE2043600	RE2043600
73	Fuse kit, 5 Amp, 5 pack (Control packs B and E) (not shown)	RE2043500	RE2043500	RE2043500
74	Fuse holder (qty of 5)	RE2000300	RE2000300	RE2000300
75	Diagnostic lights kit	R2005600	R2005600	R2005600
76	Ignition control (Single Trial)	E2311900	E2311900	E2311900
76	Ignition control (Three Trial, Control packs F and G)	E2312000	E2312000	E2312000
77	High limit, manual reset, RHCH boiler	RE0015900	RE0015900	RE0015900
77	High limit, manual reset, RHCV water heater	RE2217800	RE2217800	RE2217800
78	Temperature control, RHCH boiler	E2101400	E2101400	E2101400
79	Module, proportional control	E2104000	E2104000	E2104000
80	Timer, delay on make	E2306700	E2306700	E2306700
81	Relay, DPDT, 24V coil	E2306200	E2306200	E2306200
82	Relay, DPDT, 120V coil	E0076700	E0076700	E0076700
83	Relay, EM2 kit	RE2077700	RE2077700	RE2077700
84	Relay, 115VAC SPST	E2311100	E2311100	E2311100
85	Controller, Programmable, Electronic	E2325700	E2325700	E2325700
86	Voltage regulator	E2307200	E2307200	E2307200
87	Terminal block, 2 position	E2039500	E2039500	E2039500
88	Terminal block, 4 position	E2079400	E2079400	E2079400
89	Sensor, temperature control	E2103700	E2103700	E2103700
90	Switch, toggle, 3-way SPDT	E0109200	E0109200	E0109200
91	Switch, toggle, DPDT	E2056300	E2056300	E2056300
92	Control signal converter	R2012700	not used	not used
93	Bell, alarm, 24V	A0014300	A0014300	A0014300
94	Cover, control panel top	24B7001	24B7001	24B7001
95	Cover, control panel bottom	24B7004	24B7004	24B7004
96	Enclosure, control panel	24B7002	24B7002	24B7002
97	Voltage divider panel	24B7701	24B7701	24B7701
98	Support, control panel bottom	24B7010	24B7010	24B7010
99	Panel, diagnostic lights	24B7007	24B7007	24B7007
100	Bracket, mounting, diagnostic panel	24B7008	24B7008	24B7008
101	Standoff	24B7010	24B7010	24B7010
102	Hardware kit, control panel	R2007600	R2007600	R2007600
103	Bracket, support, control panel top	24B7009	24B7009	24B7009
104	Bracket, Low water cutoff, Remote Mount	24B7012	24B7012	24B7012
105	Switch, Low water cutoff, Manual Reset	RE2075100	RE2075100	RE2075100

HEAT EXCHANGER / WATER PATH*See Figures 34 and 35*

	1200	1600	2000	2400
110 Header cover	12A4200	16A4200	20A4200	24A4200
111 Water barrier assembly	12B4100	16B4100	20B4100	24B4100
112 Gasket, heat exchanger cover	S2011900	S2102500	S2102600	S2012300
113 Hardware kit, heat exchanger cover	R2013100	R2023700	R2023800	R2008300
114 Gauge, temperature/pressure	RA0079000	RA0079000	RA0079000	RA0079000
115 Pressure relief valve, RHCH boiler	A0063600	A0063600	A0002700	A0002700
115 Pressure relief valve, RHCV boiler	A0001200	A0001200	A0000400	A0000400
116 Immersion well, high limit	RE2058300	RE2058300	RE2058300	RE2058300
117 Immersion well, temperature control	RE2074000	RE2074000	RE2074000	RE2074000
118 Tube cleaning kit (not shown)	R2000700	R2000700	R2000700	R2000700
119 Flow switch (with paddle)	R2008400	R2008400	R2008400	R2008400
120 Temperature Control, 100° to 200° F, SPDT	E2315000	E2315000	E2315000	E2315000
121 Temperature Sensor, 1/8" NPT	E2314300	E2314300	E2314300	E2314300
122 Low water cutoff Probe Cover/Plate	R2027000	R2027000	R2027000	R2027000
123 Pipe Assembly (condenser to valve)	P2040501	P2040501	P2040501	P2040501
124 Pipe Assembly (outlet to pump)	P2040505	P2040508	P2040509	P2040503
125 Pipe Assembly (valve to pump)	P2040506	P2040506	P2040510	P2040502
126 Pipe Assembly (coil to inlet)	P2040507	P2040507	P2040504	P2040504
127 Valve Control Arm	24A9200	24A9200	24A9200	24A9200
128 Valve Connection Rod	12A9206	12A9206	20A9206	24A9206
129 Control Arm Hardware Kit	R2027100	R2027100	R2027100	R2027100
130 Actuator, Valve, Electronic	A2110000	A2110000	A2110000	A2110000
131 Bracket, Support, Actuator	24A9214	24A9214	24A9214	24A9214
132 Bracket, Mounting, Actuator/Control	12A9207	16A9207	20A9207	24A9207
133 Pipe Gasket Kit	R2027200	R2027200	R2027200	R2027200
134 Valve, Butterfly, 2-Way	A2109900	A2109900	A2109900	A2109900
135 Pipe Hardware Kit	R2027300	R2027300	R2027300	R2027300
136 Bracket, Pipe Support	24A1003	24A1003	24A1003	24A1003
137 Nipple, Close, 2" NPT	P2011700	P2011700	P2011700	P2011700
138 Elbow, Bronze, 2-1/2" Class 150	P2048400	P2048400	P2048400	P2048400
139 Soft Water Pump Assembly	A2112100	A2111500	A2111500	A2111400
Normal Water Pump Assembly	A2111500	A2111400	A2111400	A2111200
Hard Water Pump Assembly	A2111400	A2111200	A2111200	-

JACKET*See Figure 36*

	1200	1600	2000	2400
140 Panel, upper front access	24B3200	24B3200	24B3200	24B3200
141 Panel, lower front access	24B3300	24B3300	24B3300	24B3300
142 Panel, waterway access	12A3014	12A3014	20A3014	24B3014
143 Panel, waterway cover	24B3012	24B3012	24B3012	24B3012
144 Panel, pump cover	24B3016	24B3016	24B3016	24B3016
145 Panel, PRV access	24B3019	24B3019	24B3019	24B3019
146 Panel, rear access	24A3006	24A3006	24A3006	24A3006
147 Panel, front left	24B3001	24B3001	24B3001	24B3001
148 Panel, front right	24B3002	24B3002	24B3002	24B3002
149 Panel, rear left	24A3003	24A3003	24A3003	24A3003
150 Panel, rear right	24A3004	24A3004	24A3004	24A3004
151 Panel, common access	24B3005	24B3005	24B3005	24B3005
152 Panel, top	24B3007	24B3007	24B3007	24B3007
153 Panel, support	24B3008	24B3008	24B3008	24B3008
154 Panel, flue vent access	12B3010	12B3010	20B3010	24B3010
155 Panel, ducted air cover	24B3011	24B3011	24B3011	24B3011
156 Jacket trim kit	R2009600	R2009600	R2009600	R2009600
157 Hardware kit, jacket	R2009700	R2009700	R2009700	R2009700
158 Window, control / display	A2108200	A2108200	A2108200	A2108200
159 Window guide	24B3102	24B3102	24B3102	24B3102
160 Window latch	R2010000	R2010000	R2010000	R2010000
161 Jacket retro-fit kit (standard)	R2026400	R2026500	R2026600	R2026700
162 Jacket retro-fit kit (mounted pump)	R2026800	R2026900	R2027000	R2027100

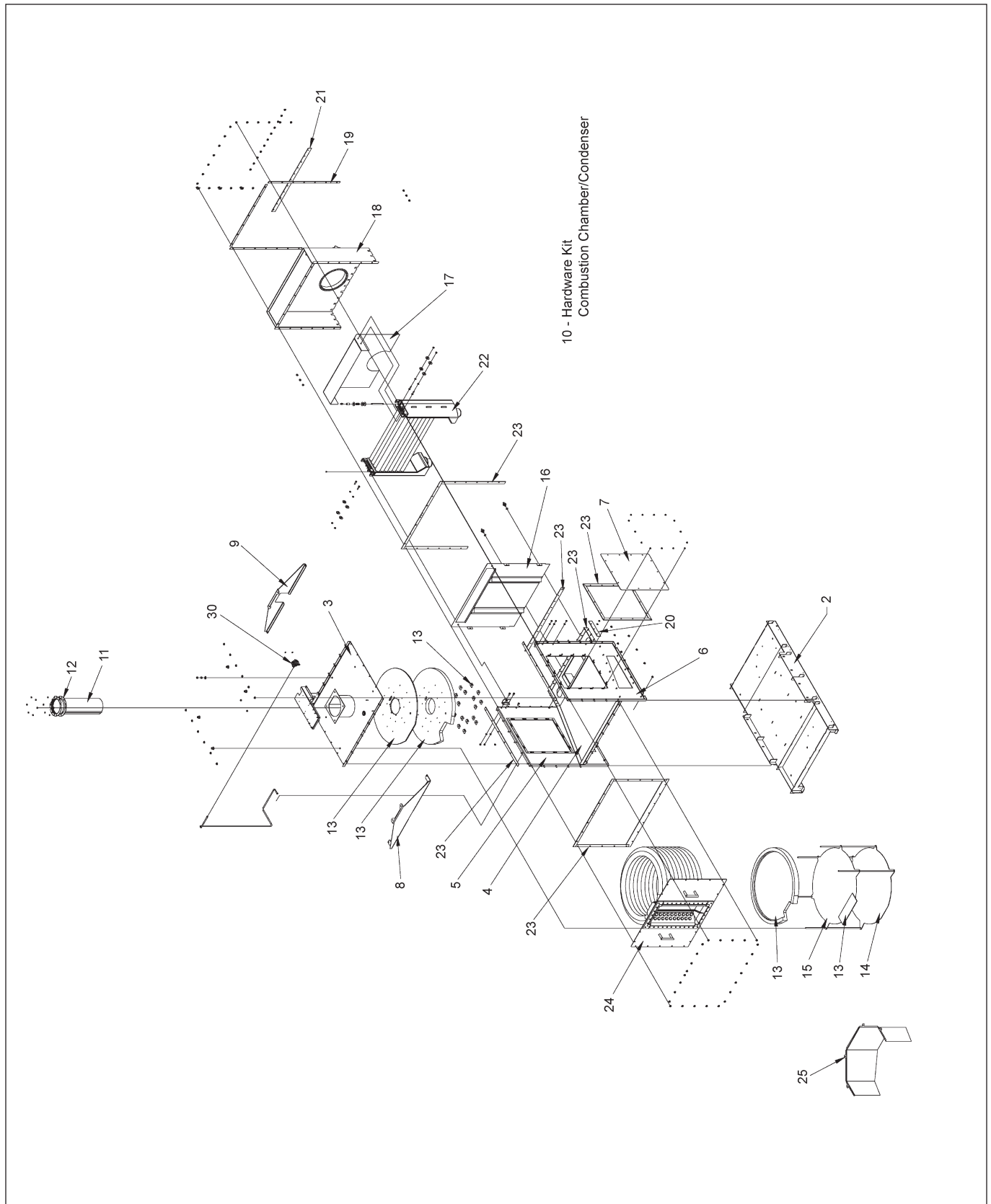

Figure 30 - Combustion Components

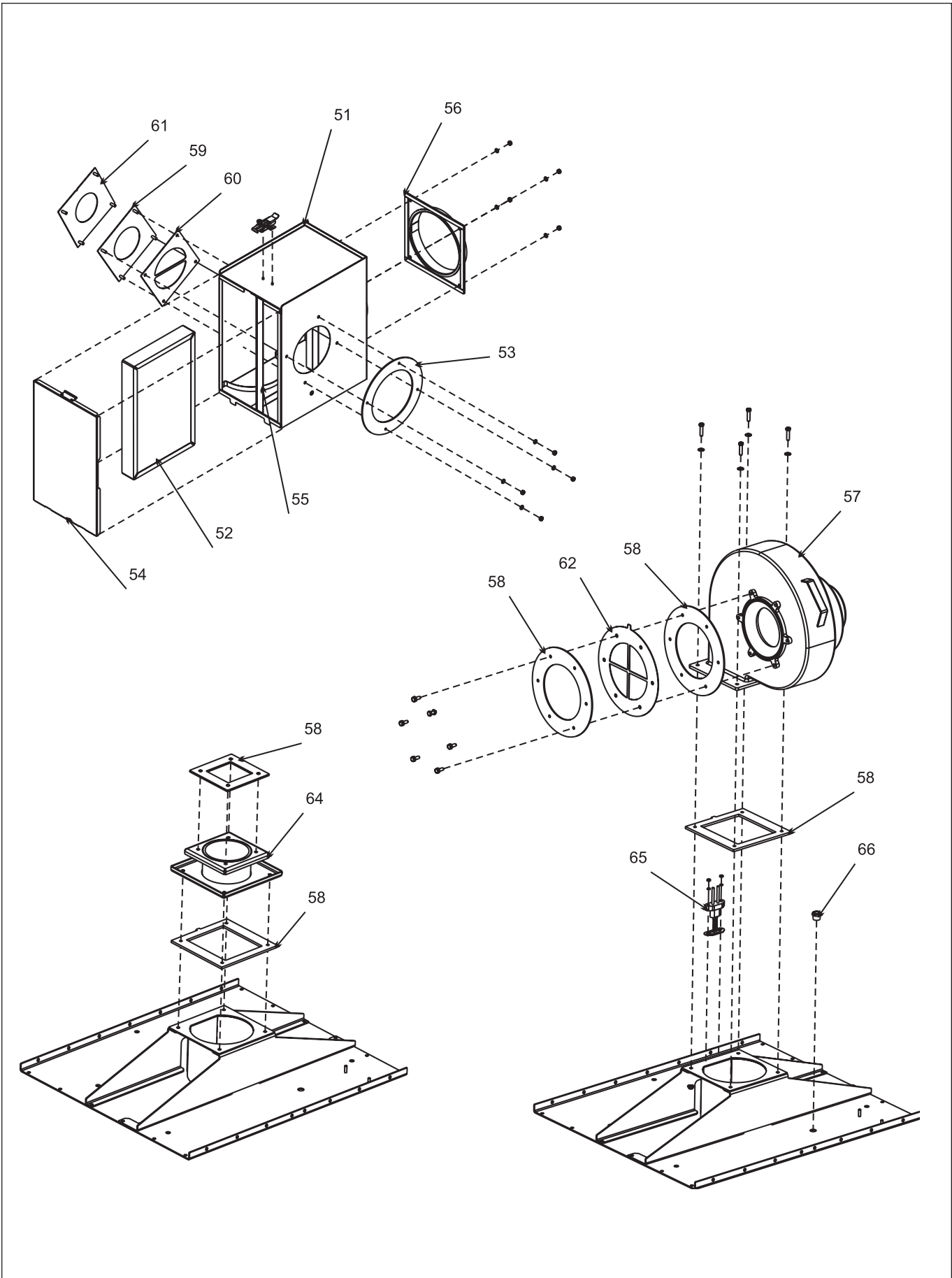

Figure 31 - Gas Train/Combustion Air Components

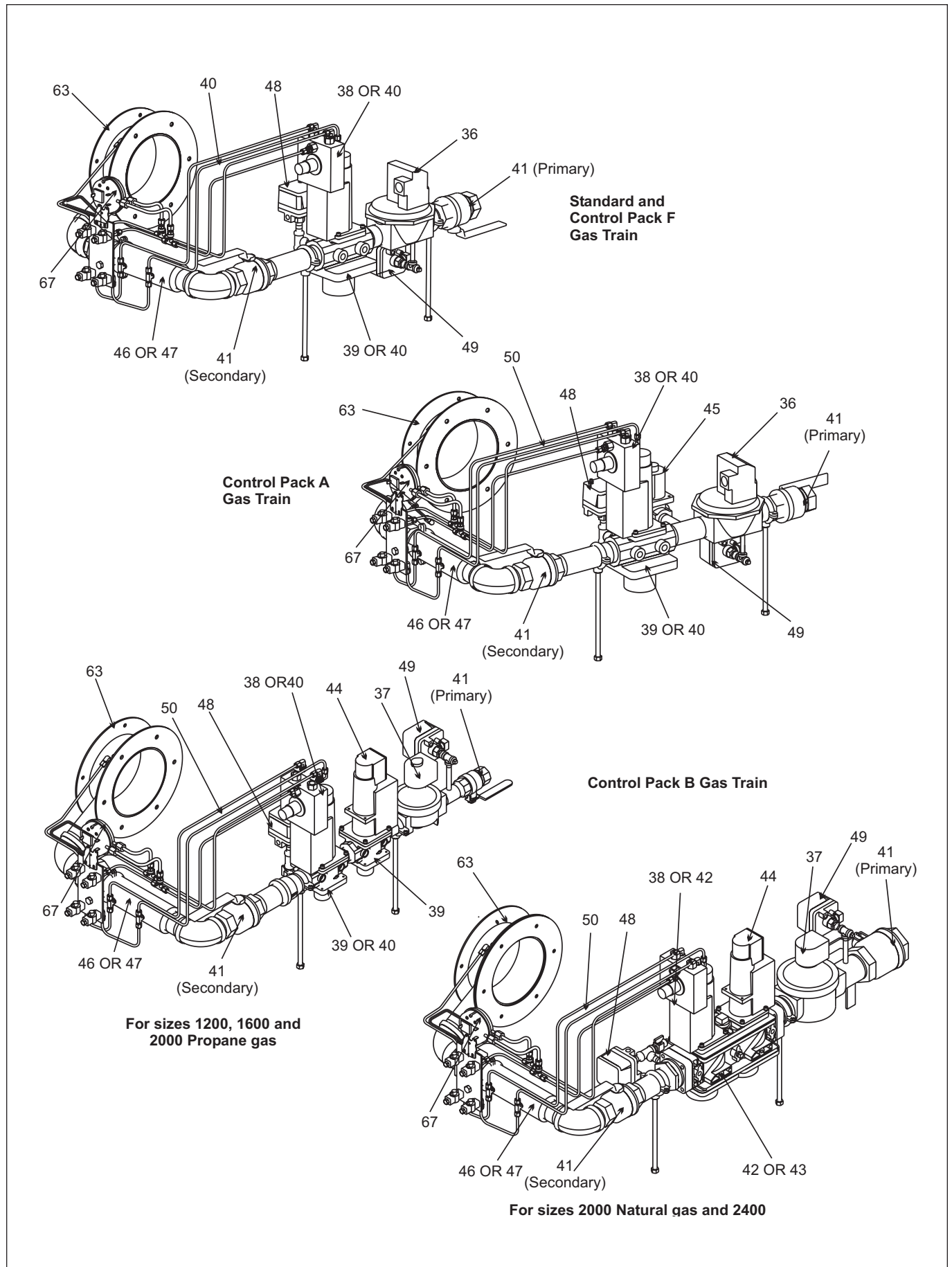

Figure 32 - Gas Train Components

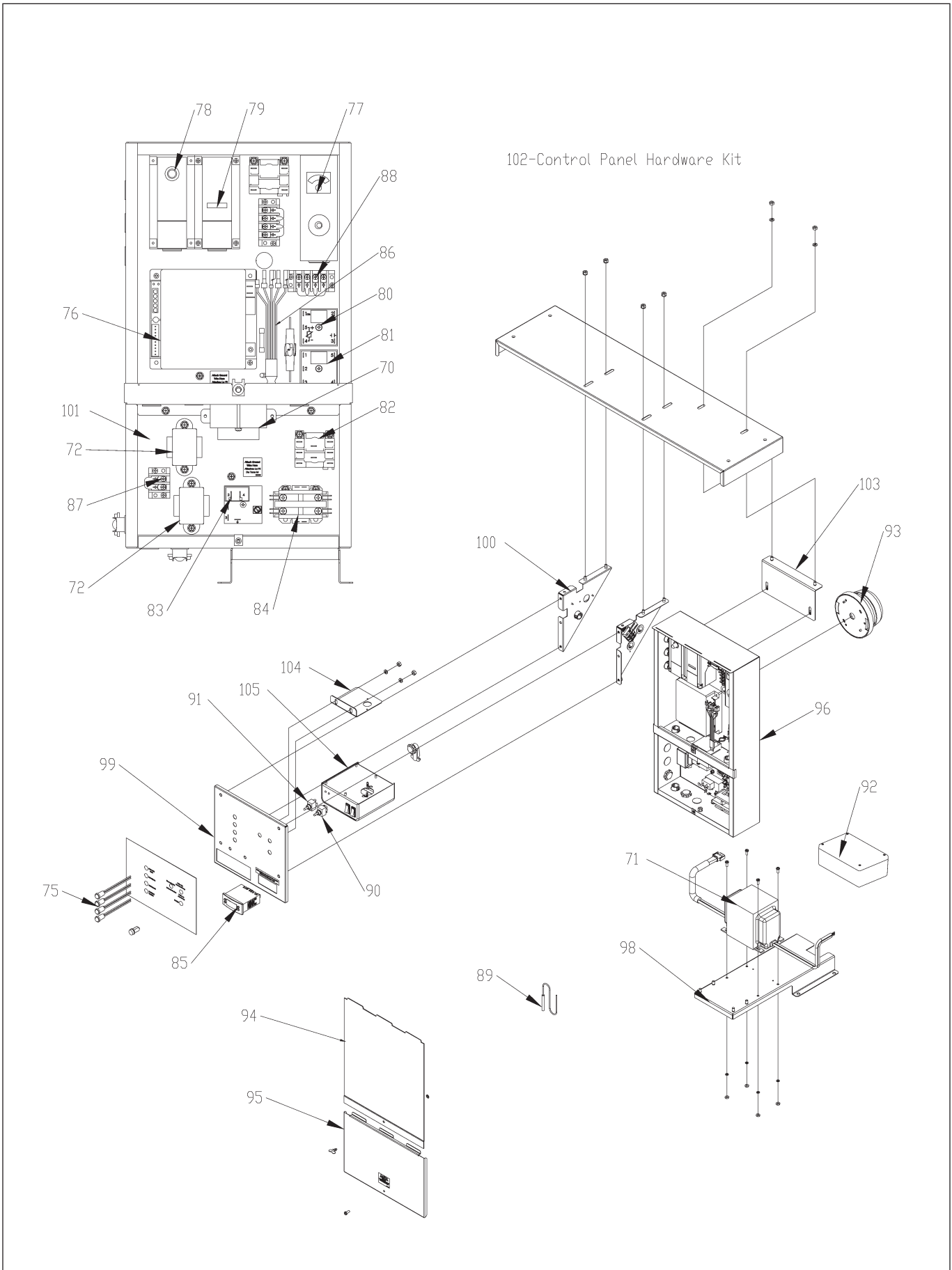

Figure 33 - Electrical Components

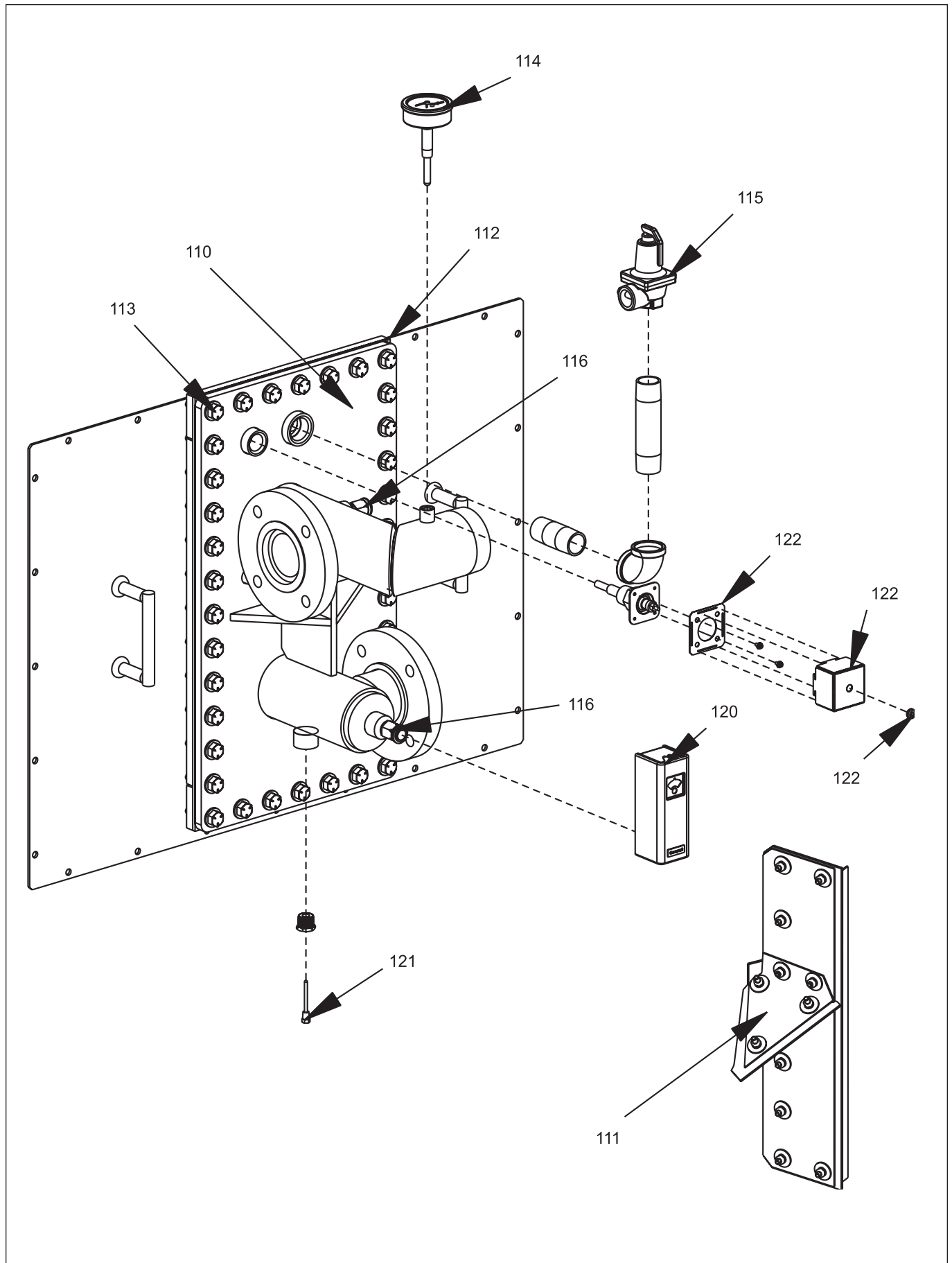

Figure 34 - Heat Exchanger / Water Path Components

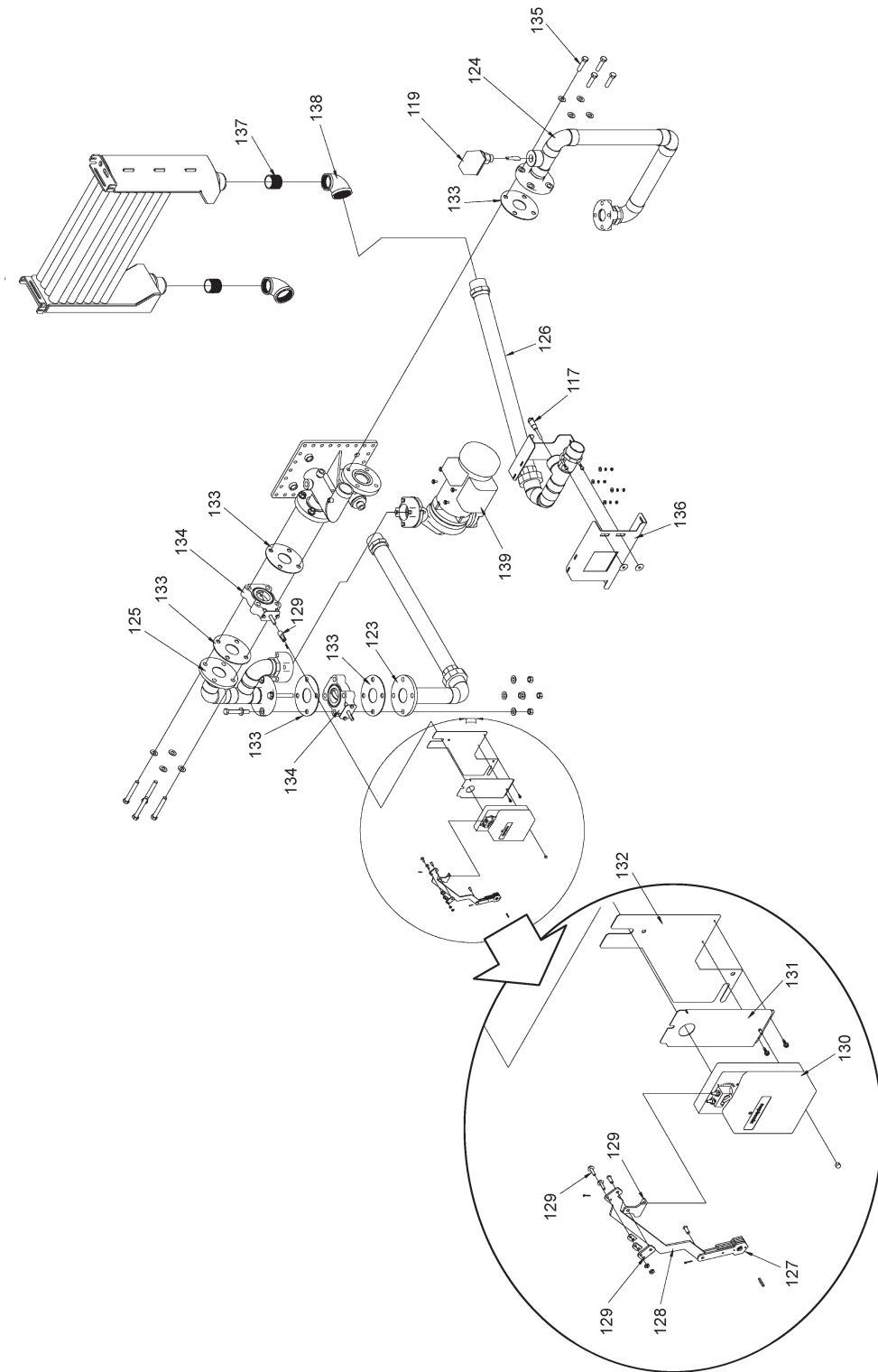

Figure 35 - Heat Exchanger / Water Path Components

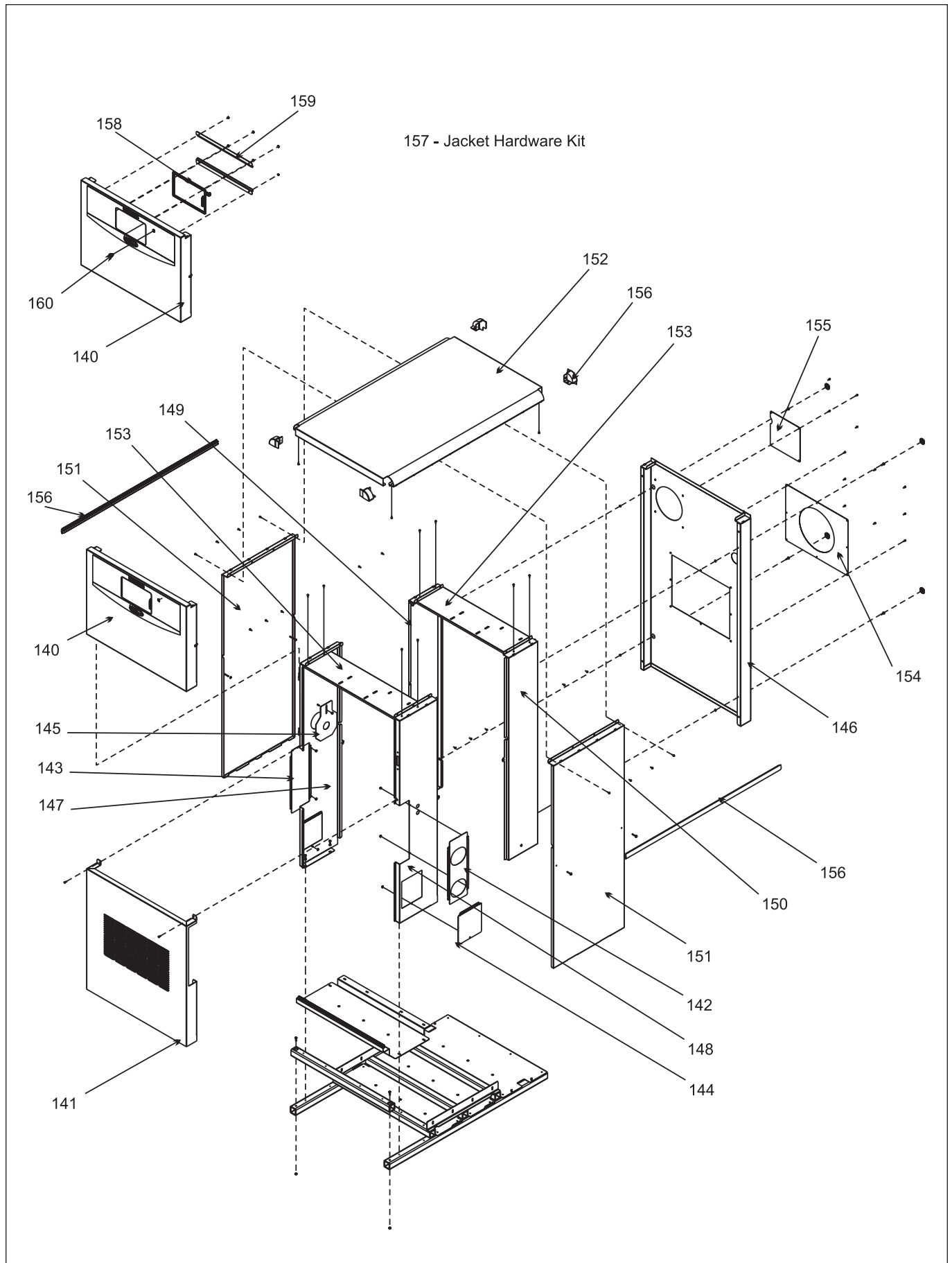

Figure 36 - Jacket Components



H2310800B



800.900.9276 • Fax 800.559.1583 (**Customer Service, Service Advisors**)
20 Industrial Way, Rochester, NH 03867 • 603.335.6300 • Fax 603.335.3355
1869 Sismet Road, Mississauga, Ontario, Canada L4W 1W8 • 905.238.0100 • Fax 905.366.0130
www.Laars.com

Litho in U.S.A. © Laars Heating Systems 0805 Document 1185B