



Instruction
No.

GF-115-V

AERCO INTERNATIONAL, Inc., Northvale, New Jersey, 07647 USA

Venting Guide



Gas Fired Boiler Systems

***Modular, Condensing, Hot Water Boilers
Models: 303, 454, 606, 757, 909, 1060***

Telephone Support

Direct to AERCO Technical Support

(8 to 5 pm EST, Mon. – Fri.)

1-800- 526-0288



AERCO International, Inc.
159 Paris Avenue
Northvale, NJ 07647-0128

www.aerco.com

© AERCO International, Inc., 2008

The information contained in this venting guide is subject to change without notice from AERCO International, Inc.

AERCO makes no warranty of any kind with respect to this material, including but not limited to implied warranties of merchantability and fitness for a particular application. AERCO International is not liable for errors appearing in this guide. Nor for incidental or consequential damages occurring in connection with the furnishing, performance, or use of this material.

TABLE OF CONTENTS

1	CODES, SAFETY AND VENTING SYSTEMS	1
1.1	APPLICABLE FEDERAL CODES	1
1.2	GAS VENT CATEGORIES	2
1.3	CERTIFIED VENTING MATERIALS FOR FLUE PIPE SYSTEMS	2
1.4	FACTORY REQUIRED INLET & VENT CONNECTION COMPONENTS	3
2	COMBUSTION AIR SYSTEM	6
2.1	COMBUSTION AIR REQUIREMENT	6
2.2	COMBUSTION AIR PIPE SIZING	9
2.3	COMMON COMBUSTION AIR PIPE SIZING	9
3	VENT SYSTEM	12
3.1	VENT INSTALLATION	12
3.2	INSTALLATION PROCEDURE FOR VENTING SYSTEM THROUGH A WALL	14
3.3	INSTALLATION PROCEDURE FOR VERTICAL VENTING	16
3.4	VENT PIPE SIZING	17
3.5	COMMON VENT PIPE SIZING	18

1 CODES, SAFETY AND VENTING SYSTEMS

1.1 APPLICABLE FEDERAL CODES



UNITED STATES:



NFPA 54/ANSI Z223.1	National Fuel Gas Code
NFPA/ANSI 211	Chimneys, Fireplaces, Vents and Solid Fuel Burning Appliances

CANADA:

CAN1-B149.1	Installation Codes for Gas-Burning Equipment
B149.2	Installation Codes for Gas-Burning Equipment

The above listed codes contain information for gas vented appliances requiring Category II, III and IV, vent sizing, location, air space clearances to combustibles and safe installation practices. The gas vent installer must be familiar with the above codes, as well as Local Codes and Regulations.

 **WARNING**  ALL INSTALLATIONS OF BOILERS AND VENTING SHOULD BE DONE ONLY BY QUALIFIED VENTING SYSTEMS PERSONNEL AND IN ACCORDANCE WITH THE MANUFACTURER'S RECOMMENDATIONS. INSTALLING OR VENTING A BOILER OR ANY OTHER GAS APPLIANCE WITH IMPROPER METHODS OR MATERIALS MAY RESULT IN SERIOUS INJURY OR DEATH DUE TO FIRE OR TO ASPHYXIATION FROM POISONOUS GASES (CARBON MONOXIDE IS ODORLESS AND INVISIBLE).

-  **WARNING** 
- FOR CORRECT INSTALLATION OF VENT SYSTEM, READ ALL OF THESE INSTRUCTIONS AND REFER TO THE VENT PIPE MANUFACTURER'S INSTRUCTIONS.
 - FAILURE TO USE THE VENTING SYSTEM DESCRIBED IN THIS DOCUMENT WILL VOID THE MANUFACTURER'S WARRANTY AND MAY RESULT IN RAPID DETERIORATION OF THE VENTING SYSTEM, CREATING A POTENTIAL HEALTH HAZARD.
 - FAULTY VENT INSTALLATION CAN ALLOW TOXIC FUMES TO BE RELEASED INTO LIVING AREAS. THIS MAY CAUSE SERIOUS BODILY INJURY OR PROPERTY DAMAGE. IMPROPER ASSEMBLY MAY ALSO AFFECT VENT PERFORMANCE.
 - INSTALL SEPARATE VENTS FOR FORCED EXHAUST APPLIANCES AND NATURAL DRAFT APPLIANCES. A COMMON VENT BETWEEN NATURAL DRAFT AND FORCED EXHAUST APPLIANCES MAY CAUSE TOXIC GASES TO EXHAUST THROUGH THE NATURAL DRAFT APPLIANCE RATHER THAN TO OUTSIDE AIR. BREATHING EXHAUST GASES WILL CAUSE SERIOUS PERSONAL INJURY OR DEATH.

VENTING GUIDE

1.2 GAS VENT CATEGORIES



The Modulex boiler is approved for a Category IV vent configuration as well as for sealed combustion installations. Provisions for combustion and ventilation air in accordance with Section 5.3, (Air for Combustion and Ventilation) of the National Fuel Gas Code - ANSI Z223.1, or Sections 7.2, 7.3, or 7.4 of CAN/CGA B149, Installation Codes, or applicable provisions of the local building codes.

Federal Codes have categorized gas appliances by the vented flue gas pressure and temperature:

- **Category I**, being a gas appliance that operates with a non-positive vent (or natural drafted vent) connector with a flue gas pressure and temperature at least 140°F (60°C) above its dew point.
- **Category II**, being a gas appliance that operates with a non-positive vent (or natural drafted vent) connector with a flue gas pressure and temperature less than 140°F (60°C) above its dew point.
- **Category III**, being a gas appliance that operates with a positive vent (fan forced vent) connector with a flue gas pressure and temperature at least 140°F (60°C) above its dew point.
- **Category IV**, being a gas appliance that operates with a positive vent (fan forced vent) connector with a flue gas pressure and temperature less than 140°F (60°C) above its dew point.
- **Direct Vent**, a gas appliance is constructed and installed so that all air for combustion is derived directly from the outdoors and all flue gases are discharged to the outdoors.

1.3 CERTIFIED VENTING MATERIALS FOR FLUE PIPE SYSTEMS

Acceptable materials and manufacturers for flue vent pipe systems are listed below in Option #1 and Option #2.



The Vent Pipe Systems below are used for venting gas burning Category IV appliances. Do not use these vent pipe systems for venting appliances burning fuels such as wood, coal, oil or kerosene.



Maintain clearances from combustible construction for boiler, vent connector, and steam and hot-water pipes.



Do not use these vent pipe systems for incinerators of any kind.

OPTION #1 - AL29-4C STAINLESS STEEL

- Flex-L International Inc., StaR 34 Vent
- Heat-Fab Inc., Saf-T Vent
- Z-Flex Z-Vent
- Protech System Inc., Fas N Seal Vent
- Metal-Fab Inc., Corr/Guard Vent

OPTION #2 – NON-METALLIC – Use Schedule 40 or thicker, Single-wall, Uninsulated pipes

NOTE:

When using Non-Metallic (Plastic) vent systems for Canadian installations, per CSA B149.1, use vent systems that are certified to the Standard for Type BH Gas Venting Systems, ULC-S636. The plastic components, primers and glues of the certified vent system must be from a single system manufacturer and not inter-mixed with other manufacturers vent system parts.

1. PVC

- ASTM F891
- ASTM D2665
- ASTM D1785
- ASTM D2241

2. CPVC

- ASTM D2846
- ASTM F411
- ASTM F442

1.4 FACTORY REQUIRED INLET & VENT CONNECTION COMPONENTS

The following tabular listing shows the components and part numbers for connecting the air inlet and the exhaust vents for each Modulex model. For installation flexibility, connectors are provided for left hand, right hand, and rear connections. Basic drawings of the connection components and assemblies are shown in Figures 1 through 4.

COMPONENT	MLX303, MLX454 & MLX606 4 inch Part Numbers	MLX757, MLX909 & MLX1060 6 inch Part Numbers
Rear Air Inlet - PVC	39041	39042
Side Air Inlet - PVC	39049	39050
Exhaust - PVC	49051	49050
Exhaust - Stainless Steel AL29-4C	49052	49053
Unused Side Air Filter Blind Cover	39048 (2 Required for MLX606)	39048 (2 Required)
Unused Rear Air Filter Blind Cover	N/A	36006

When using sealed combustion, observe the following requirements:

- Only one filter is required for each boiler. For models that are shipped with more than one filter, the extras can be kept as spares (2 filters included with Modulex 606 & 757, 3 filters included with Modulex 909 and 1060).
- For Modulex 303, 454, 606, and 757 filters are installed on the side air inlet connections when shipped from the factory. If sealed combustion is connected at the rear, a filter must be moved from the side to the rear of the boiler.
- The unused right side or left side air inlet connection must be covered with a blind cover (See Figures 2 and 3)
- Unused rear air inlet connection must be covered with the back blind cover (See Figure 4).

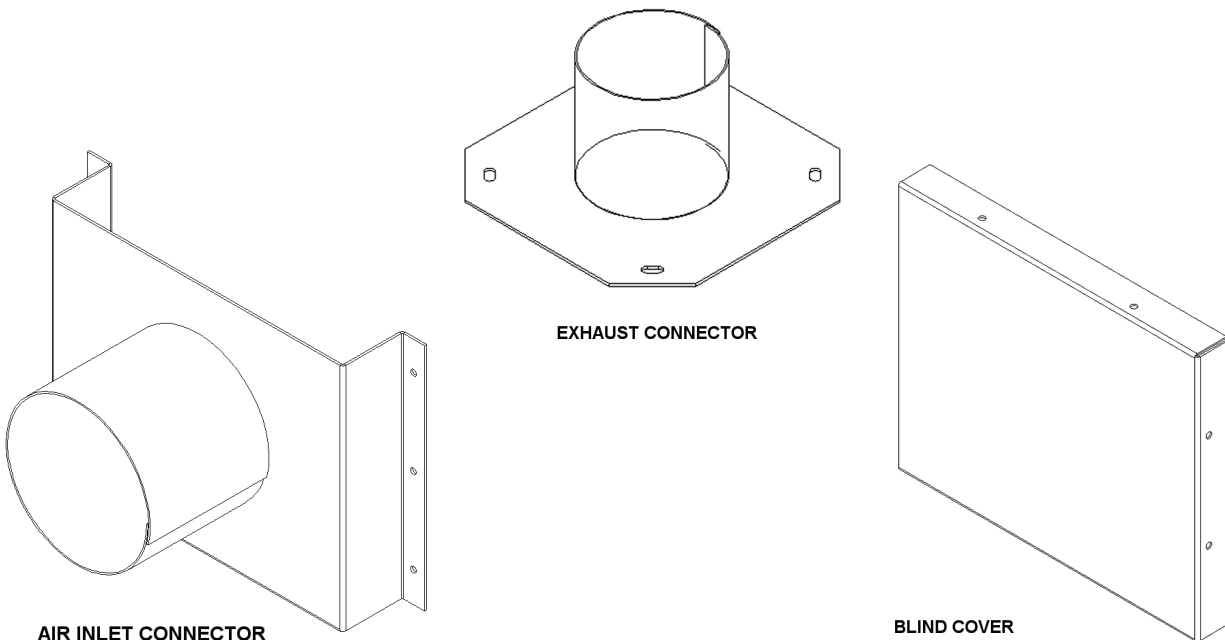

FIGURE 1

VENTING GUIDE

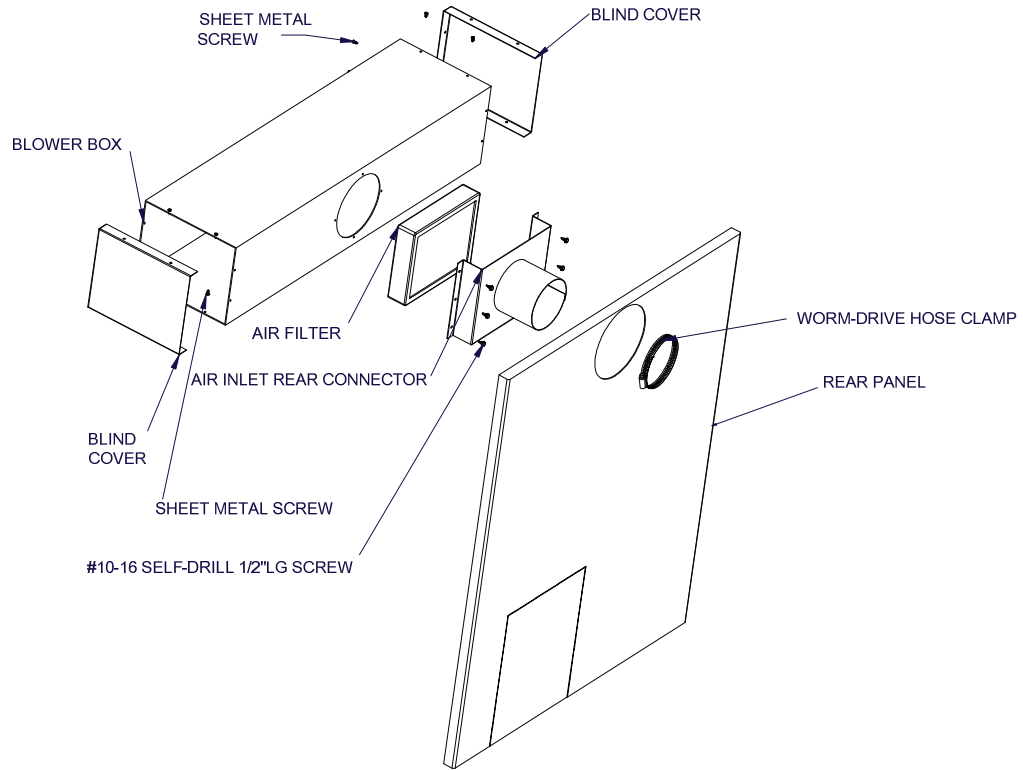

FIGURE 2

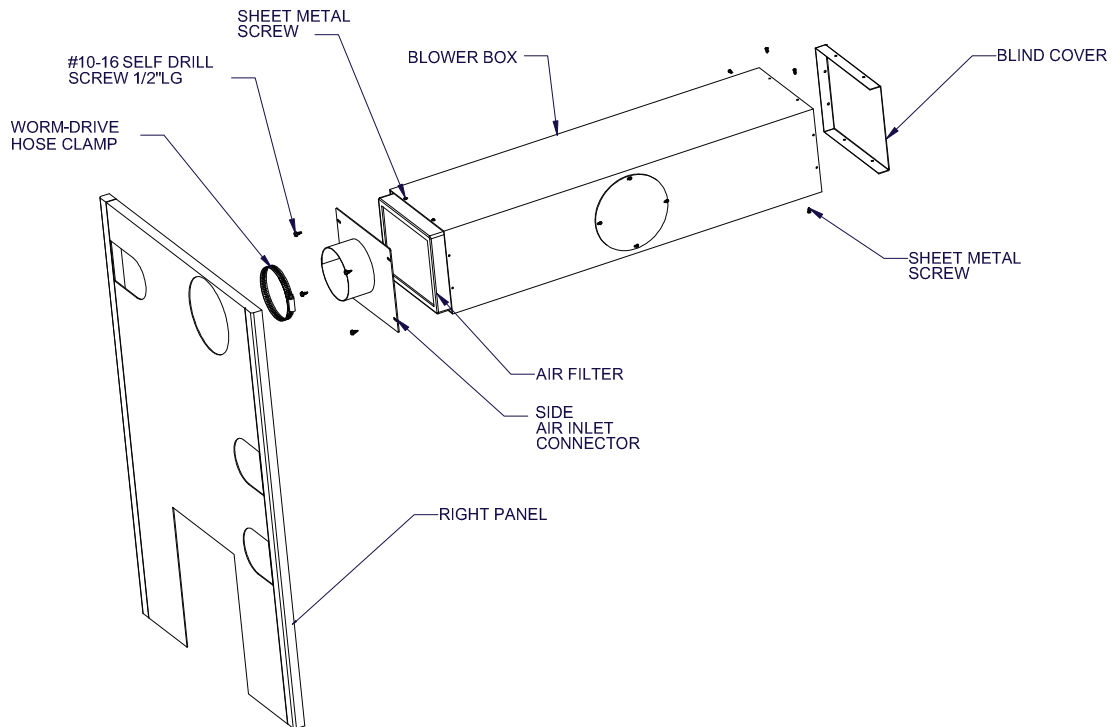

FIGURE 3

VENTING GUIDE

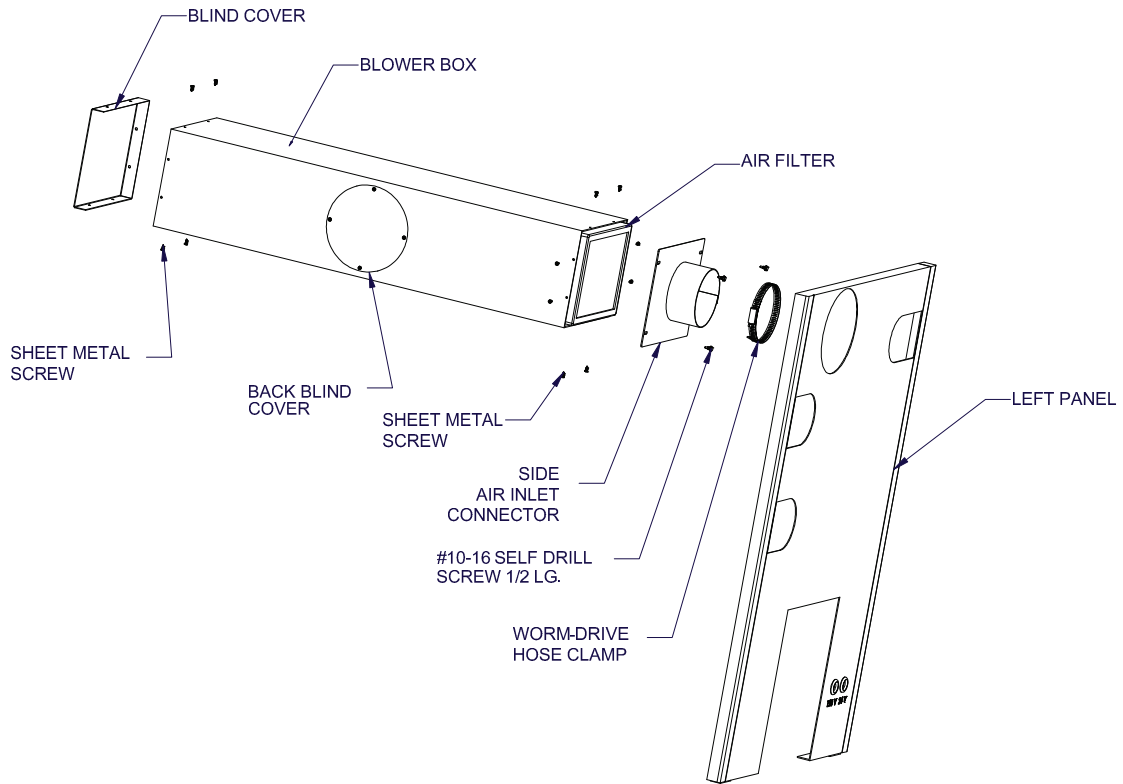

FIGURE 4

2 COMBUSTION AIR SYSTEM



AIR OPENINGS TO COMBUSTION AREA MUST NOT BE OBSTRUCTED. USING THE FOLLOWING CHART, ADEQUATE COMBUSTION AIR CAN BE MAINTAINED.

2.1 COMBUSTION AIR REQUIREMENTS

The following tabular listing shows the minimum required air openings in square inches (square centimeters) freely communicating with the outdoors for boiler room combustion and ventilation air for each boiler. For multiple boiler installations, sum the openings for the specific boiler sizes.

Minimum Required Air Openings Freely Communicating With the Outdoors For Boiler Room Combustion & Ventilation Air

Model No.	Two Sealed Combustion or Vertical Ducts <u>Each</u> having an opening in sq. in. (sq.cm) of:	Two Horizontal Ducts <u>Each</u> having an opening in square inches of	Single Permanent Opening
MLX-303	76 in ² (490 cm ²)	152 in ² (980 cm ²)	101 (651)
MLX-454	114 in ² (735 cm ²)	228 in ² (1471 cm ²)	152 (980)
MLX-606	152 in ² (980 cm ²)	304 in ² (1961 cm ²)	202 (1303)
MLX-757	190 in ² (1226 cm ²)	380 in ² (2451 cm ²)	253 (1632)
MLX-909	228 in ² (1471 cm ²)	456 in ² (2941 cm ²)	303 (1954)
MLX-1060	266 in ² (1716 cm ²)	532 in ² (3431 cm ²)	354 (2283)

1. The combustion air must be free of chlorine, halogenated hydrocarbons or other chemicals that can become hazardous when used in gas-fired equipment. Common sources of these compounds are swimming pools, degreasing compounds, plastic processing, and refrigerants. Whenever the environment contains these types of chemicals, combustion air **MUST** be supplied from a clean area outdoors for the protection and longevity of the equipment and warranty validation.
2. Ventilation of the boiler room must be adequate enough to provide sufficient air to properly support combustion.
3. When combustion air is brought from outside the building, the boiler room shall be provided with two permanent openings, one commencing 12 inches from the top and one commencing within 12 inches from the bottom of the room see Figures 5 and 6. The openings shall communicate directly, or by ducts, freely with the outdoors. One of the following methods must be made to provide adequate air for ventilation and combustion.
 - a. When directly communicating with the outdoors, each opening shall have a minimum free area of 1 square inch per 4,000 BTU per hour of total input rating of all equipment in the room.
 - b. When communicating with the outdoors by means of vertical ducts, each opening shall have a minimum free area of 1 square inch per 4,000 BTU per total input rating of all appliances in the room.
 - c. If horizontal ducts are used, each opening and duct shall have a minimum free area of 1 square inch per 2,000 BTU per hour of total input rating of all appliances in the room.



WARNING

- Non-motorized louvers and grilles must be fixed in an open position.
- Minimum screens mesh size shall not be smaller than ¼ inch mesh.

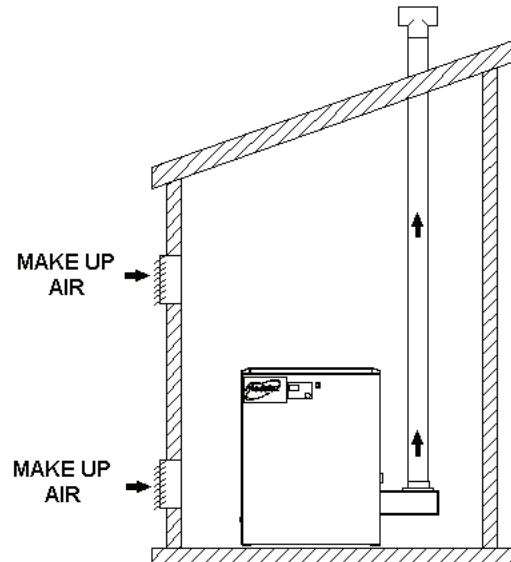

FIGURE 5

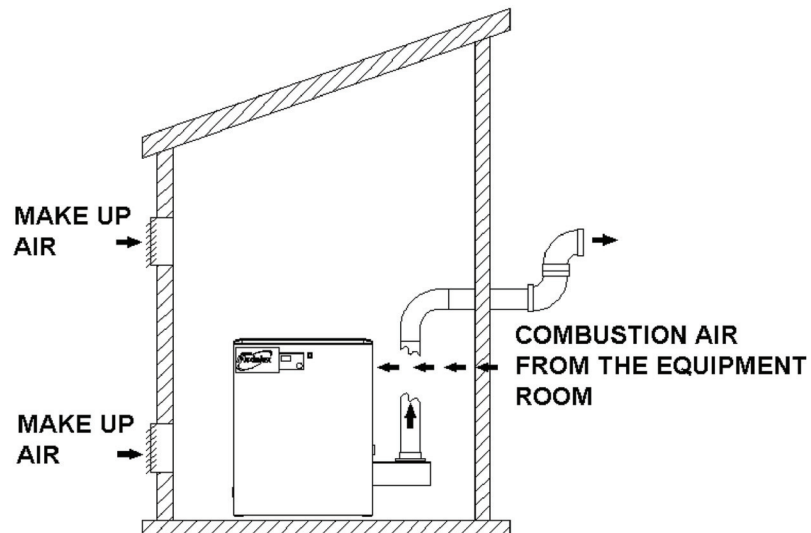

FIGURE 6

4. When calculating free area using louvers and grilles, the required size of the openings for combustion, ventilation, and dilution air shall be based on the total free area of each opening.

If the free area through a designed louver or grille is known, it shall be used in calculating the size of opening required to provide the free area specified.

If the louver and grille design free areas are not known, the following will be assumed for wooden louvers a 25 percent free area, and for metal louvers and grilles a 75 percent free area opening.

VENTING GUIDE

5. When terminating the combustion air through the roof:
 - a Combustion air inlet must be 3 ft below any vent outlet within 10 ft. See Figure 7.
 - b Combustion air inlet must also face away from the vent outlet. See Figure 7.
6. All inlet air ducts must be sealed air tight.
7. When using sealed combustion, the combustion air inlet and vent outlet must be located on the same surface (same wall, roof, etc.). See Figures 7 and 8.

This is required so that equal pressure zones are acting on both the air inlet and vent outlet. This makes the installation a balanced vent system which helps maintain stable combustion characteristics.

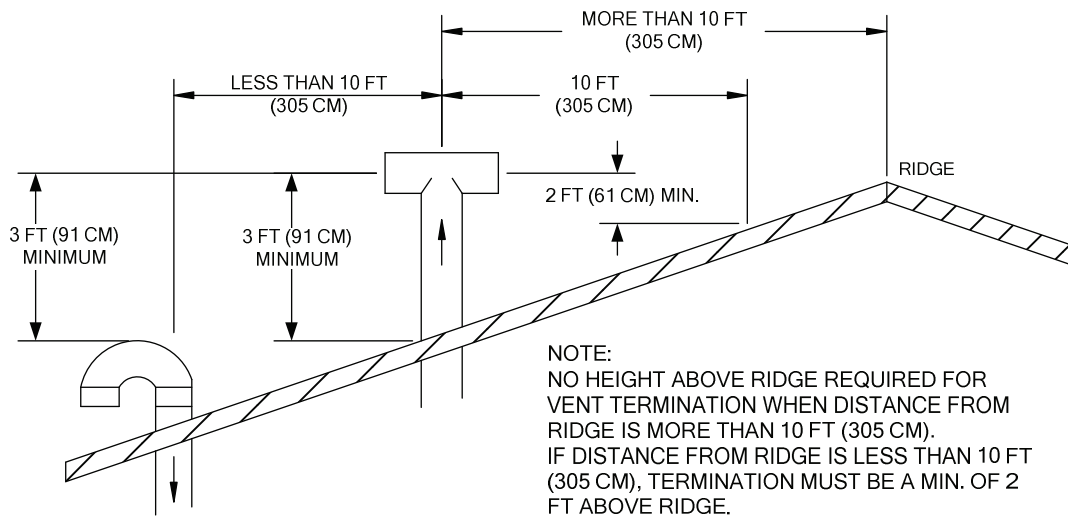

FIGURE 7

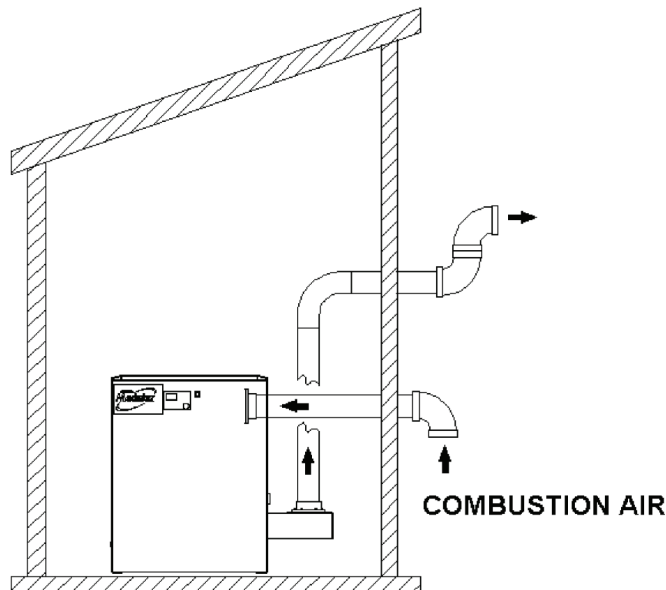

FIGURE 8

2.2 COMBUSTION AIR PIPE SIZING

The maximum length is the combined length of straight horizontal and vertical runs, and the equivalent straight length of fittings. The required lengths for each boiler are as follows:

Model No.	MLX-303	MLX-454	MLX-606	MLX-757	MLX-909	MLX-1060
Number of Modules	2	3	4	5	6	7
Combustion Air Diameter	4" (102 mm)	4" (102 mm)	4" (102 mm)	6 (152 mm)	6 (152 mm)	6 (152 mm)
Maximum Combustion Air Equivalent Feet (Meters)	100 (30.5 m)	100 (30.5 m)	100 (30.5 m)	100 (30.5 m)	100 (30.5 m)	100 (30.5 m)

Model No.	Pipe Diameter	Equivalent Pipe Lengths Examples			Maximum Length Equivalent Ft (m)
		Sharp 90° Elbow Equiv. Ft (m)	Sweep 90° Elbow Equiv. Ft (m)	45° Elbow Equiv. Ft (m)	
MLX-303 MLX-454 MLX-606	4" (102 mm)	10 ft. (3.05 m)	5 ft. (1.5 m)	5 ft. (1.5 m)	100 ft. (30.5 m)
MLX-757 MLX-909 MLX-1060	6" (152 mm)	10 ft. (3.05 m)	N/A	5 ft. (1.5 m)	100 ft. (30.5 m)

The maximum pressure drop of the vent is also 100 equivalent feet (30.5 m). See Section 3.4. Note that this does **NOT** mean the allowed combined pressure drop between the vent and combustion air is 200 equivalent feet (61 m). That is, the vent cannot go above 100 equivalent feet (30.5 m), even if the combustion air is less than 100 equivalent feet, and vice versa.

Examples:

1. A 40 foot length of combustion air pipe and 1 sharp 90° elbow add up to 40 ft + 10 ft = 50 equivalent ft (15.2 m).
2. A 30 foot length of combustion air pipe and 2 sharp 90° elbows add up to 30 ft + (2 x 10 ft) = 50 equivalent ft (15.2 m).

2.3 COMMON COMBUSTION AIR PIPE SIZING

Refer to Figures 9 and 10 for typical common combustion air inlet installation. The maximum length is the sum of the equivalent straight length of horizontal runs, vertical runs, and fittings of the individual combustion air connector and the common combustion air pipe. The required diameter lengths for a given Modulex total BTU/hr Input are as follows:

VENTING GUIDE

Total BTU/hr Input (up to and including)	606,000	1,212,000	2,120,000	3,180,000
Common Combustion Air Diameter	4" (102 mm)	6" (152 mm)	8" (203 mm)	10" (254 mm)
Maximum Combustion Air → Individual Connector <u>plus</u> Common Combustion Air Equivalent Feet (Meters)	100 (30.5 m)	100 (30.5 m)	100 (30.5 m)	100 (30.5 m)

Total BTU/hr Input (up to and including)	Common Pipe Diameter	Equivalent Common Pipe Lengths Examples				Maximum Length → Individual Connector <u>plus</u> Common Combustion Air Equivalent Ft (m)
		Sharp 90° Elbow Equiv. Ft (m)	Sweep 90° Elbow Equiv. Ft (m)	45° Elbow Equiv. Ft (m)	WYE Equiv. Ft (m)	
606,000	4" (102 mm)	10 ft. (3.05 m)	5 ft. (1.5 m)	5 ft. (1.5 m)	5 ft. (1.5 m)	100 ft. (30.5 m)
1,212,000	6" (152 mm)	10 ft. (3.05 m)	N/A	5 ft. (1.5 m)	5 ft. (1.5 m)	100 ft. (30.5 m)
2,120,000	8" (203 mm)	10 ft. (3.05 m)	N/A	5 ft. (1.5 m)	5 ft. (1.5 m)	100 ft. (30.5 m)
3,180,000	10" (254 mm)	10 ft. (3.05 m)	N/A	5 ft. (1.5 m)	5 ft. (1.5 m)	100 ft. (30.5 m)

NOTES:

- The chart above shows equivalent pipe lengths of the fittings for the common combustion air pipe. See section 2.2 for equivalent lengths for fittings for the individual boiler connector.
- The maximum equivalent length shown is the sum of the equivalent length of the longest individual connector plus the equivalent length of the common combustion air pipe. **If the maximum equivalent length exceeds 100 equivalent ft, contact your AERCO sales representative or AERCO International for design assistance and approval.**
- It is important to use a WYE as a means to connect the individual combustion air pipe into the common combustion air pipe. This will ensure the least amount of pressure drop. Do NOT use a TEE, 90°, or 45° elbow.

The maximum pressure drop of the vent is also 100 equivalent feet (30.5 m). See Section 3.43.5. Note that this does **NOT** mean that the allowed combined pressure drop between the vent and combustion air is 200 equivalent feet (61 m). That is, the vent cannot go above 100 equivalent feet (30.5 m), even if the combustion air is less than 100 equivalent feet, and vice versa.

Examples:

The combustion air system of two MLX-1060 (2 x 1,060,000 BTU/hr = 2,120,000 BTU/hr) consists of 40 foot length of common combustion air pipe and 3 sharp 90° elbows. Each individual combustion air connector consists of 10 ft straight run and one WYE.

Common Combustion air pipe: 40 ft + (3 x 10ft) = 70 equivalent ft (21.3 m)

Individual combustion air connector: 10 ft + 5 ft = 15 equivalent ft (4.6 m)

Total Combustion air equivalent length: 70 ft + 15 ft = 85 (25.9 m)

85 equivalent ft is LESS than 100 equivalent feet: OK to use 8" Common air intake piping and 6" individual connectors.

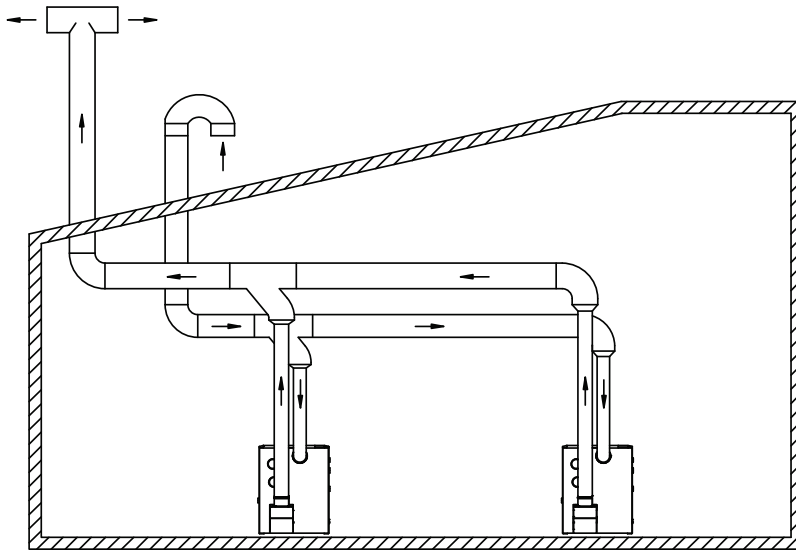

FIGURE 9

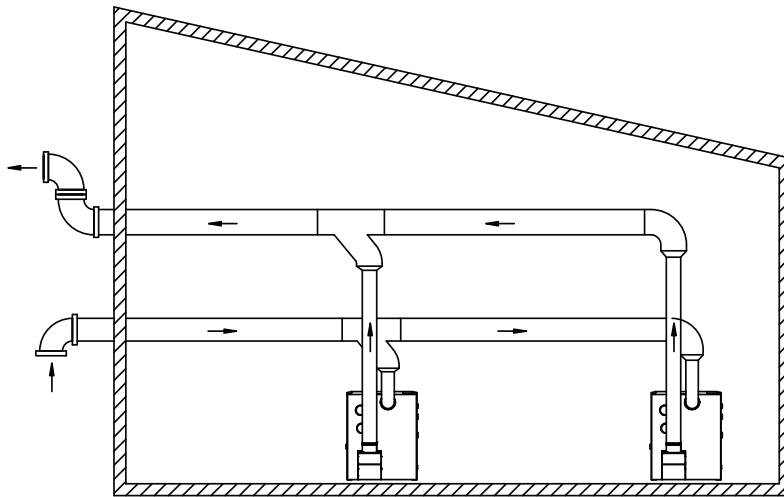

FIGURE 10

VENTING GUIDE

3 VENT SYSTEM

The boiler vent is fundamental for correct operation. Being a condensing boiler, combustion gases are discharged at a very low temperature. It is therefore necessary for the venting system to be perfectly impermeable to combustion products condensate and to be made of corrosion resistant materials. Typical Category IV venting and sealed combustion illustrations are shown in Figure 5 through 8. The various funnel joints shall be well sealed and/or equipped with suitable gaskets, in order to avoid any condensate drain and/or air intake. Ensure that the boiler vent's section and height conform to national and local regulations (see 1.1 APPLICABLE FEDERAL CODES of this guide).

For boilers designed for connection to gas vents or chimneys, vent installations shall be in accordance with Part 7, Venting of Equipment, of the National Fuel Gas Code, ANSI Z223.1, or Section 7, Venting Systems and Air Supply for Appliances, of the CAN/CGA B149, Installation Codes, or applicable provisions of the local building codes.

The vent system for the Modulex boilers must be installed in accordance with AERCO's installation instructions described in this guide.



For Category IV Boilers, the vents must be installed to prevent accumulation of condensate, and have means provided for drainage of condensate.

3.1 VENT INSTALLATION

1. The boilers covered in this section are design-certified as Category IV for venting, only when they are installed with manufacturer specified vent system components and installation practices.
2. Install vent pipe beginning at the boiler vent connector and work toward the vent cap. To attach the exhaust connector to the flue collector, use the screws and the gasket supplied inside the plastic bag. Use a cross-tip (Phillips) screwdriver at least 12 inches (300 mm) long. See Figure 11.
3. Vent pipe and fittings **MUST NOT** be routed into, through, or within any other vent, such as an existing masonry chimney or factory built chimney. Vent connectors serving appliances vented by natural draft shall not be connected into any portion of mechanical draft systems operating under positive pressure.
4. For Modulex boilers, horizontal runs shall be sloping upwards not less than 1/4 inch per foot (21 mm/m) from the boiler to the vent termination.
5. Modulex boilers must be vented individually.
6. The instructions for the installation of the venting system shall specify that the horizontal portions of the venting system shall be supported to prevent dips or sags where condensate could collect.
7. Rigidly support vent pipe every 5 feet and at the elbows. Plumber straps may be used.
8. Clearances and enclosures. ALL vent pipe and fittings must be installed with appropriate air space clearances to combustibles. These air space clearances apply to indoor or outdoor vents, whether they are open, enclosed, horizontal or vertical or pass through floors, walls, roofs, or framed spaces. The appropriate air space clearances should be observed between joists, studs, sub floors, plywood, drywall, or plaster enclosures, insulated sheathing, rafters, roofing, and any other combustible material. The minimum air space clearance also applies to electrical wires and any kind of building insulation. For horizontal runs, maintain a minimum air space clearance of 0 inches for 4 inch and 6 inch vent pipe to any combustible material, electric wires, and building materials

VENTING GUIDE

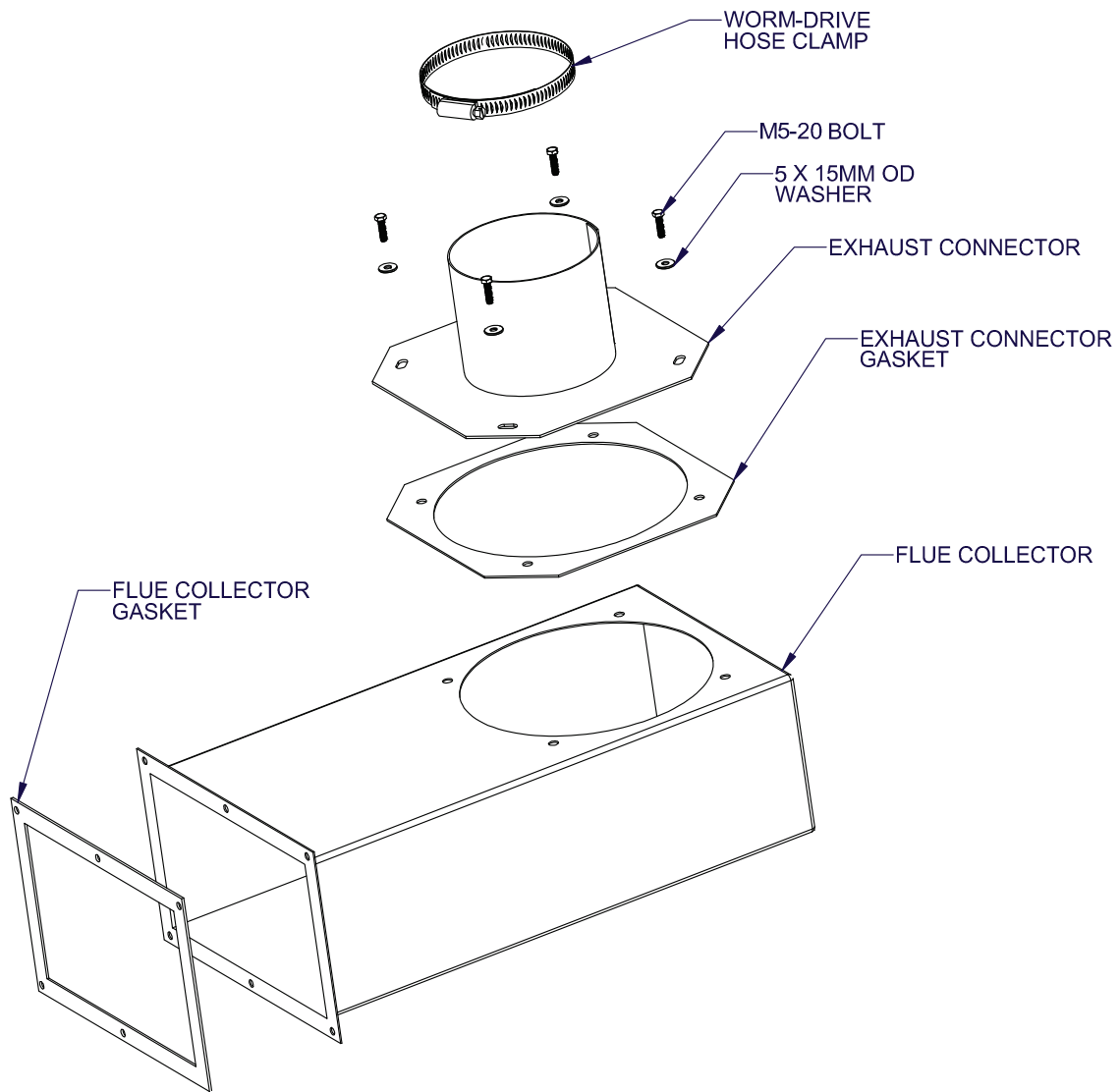

FIGURE 11

VENTING GUIDE



DO NOT INSULATE OR OTHERWISE WRAP VENT PIPE OR FITTINGS.

Paragraphs 3.2 and 3.3 discuss specific installation regulations for side-wall and vertical terminations, respectively.

3.2 INSTALLATION PROCEDURE FOR VENTING SYSTEM THROUGH A WALL

The minimum distances from adjacent public walkways, adjacent buildings, operable windows and building openings shall not be less than those values specified in the National Fuel Gas Code, ANSI Z223.1 and/or CAN/CGA B149, Installation Codes.

Minimum clearance of 4 feet (1.22 m) horizontally from, and in no case above or below, unless a 4-foot (1.22 m) horizontal distance is maintained, from electric meters, gas meters, regulators and relief equipment.

Refer to the notes below and Figure 12, when determining the location of the vent outlet.

- a. At least 12 inches (31 cm) above finished grade, or at least 12 inches (31 cm) above the normally expected snow accumulation level in geographical areas where snow accumulates. With a vent termination clearance of at least 4 feet (122 cm) from any air openings into a building.
- b. **In Massachusetts**, when side-wall venting is used, the vent termination must be located a minimum of 4 feet above grade.

For detailed information pertaining to side-wall venting within the Commonwealth of Massachusetts, see pages v and vi in GF-115 (models w/50 psig max. working press.) or GF-115-H (models w/92 psig working press.).

- c. At least 3 feet (92 cm) above any forced air inlet located within 10 feet (305 cm).
- d. At least 4 feet (122 cm) horizontally from electric meters, gas meters, regulators and relief equipment.
- e. For horizontal runs, keep a minimum air space clearance from any combustible material, electric wires, and building insulation of 0 inches (0 cm) for 0 (0 cm) vent pipe.
- f. Do not terminate vent over public walkways or over an area where condensate or vapor could create a nuisance or hazard or could be detrimental to the operation of regulators, relief valves, or other equipment.
- g. Do not locate the vent termination too close to shrubbery as flue products may stunt growth or kill them.
- h. Some building materials may be affected by flue products expelled near unprotected surfaces. Sealing or shielding of exposed surfaces with a corrosion resistant material (such as aluminum sheet) may be required to prevent staining or deterioration.
- i. See the National or Canadian Codes listed at the beginning of these instructions for additional information on termination location.

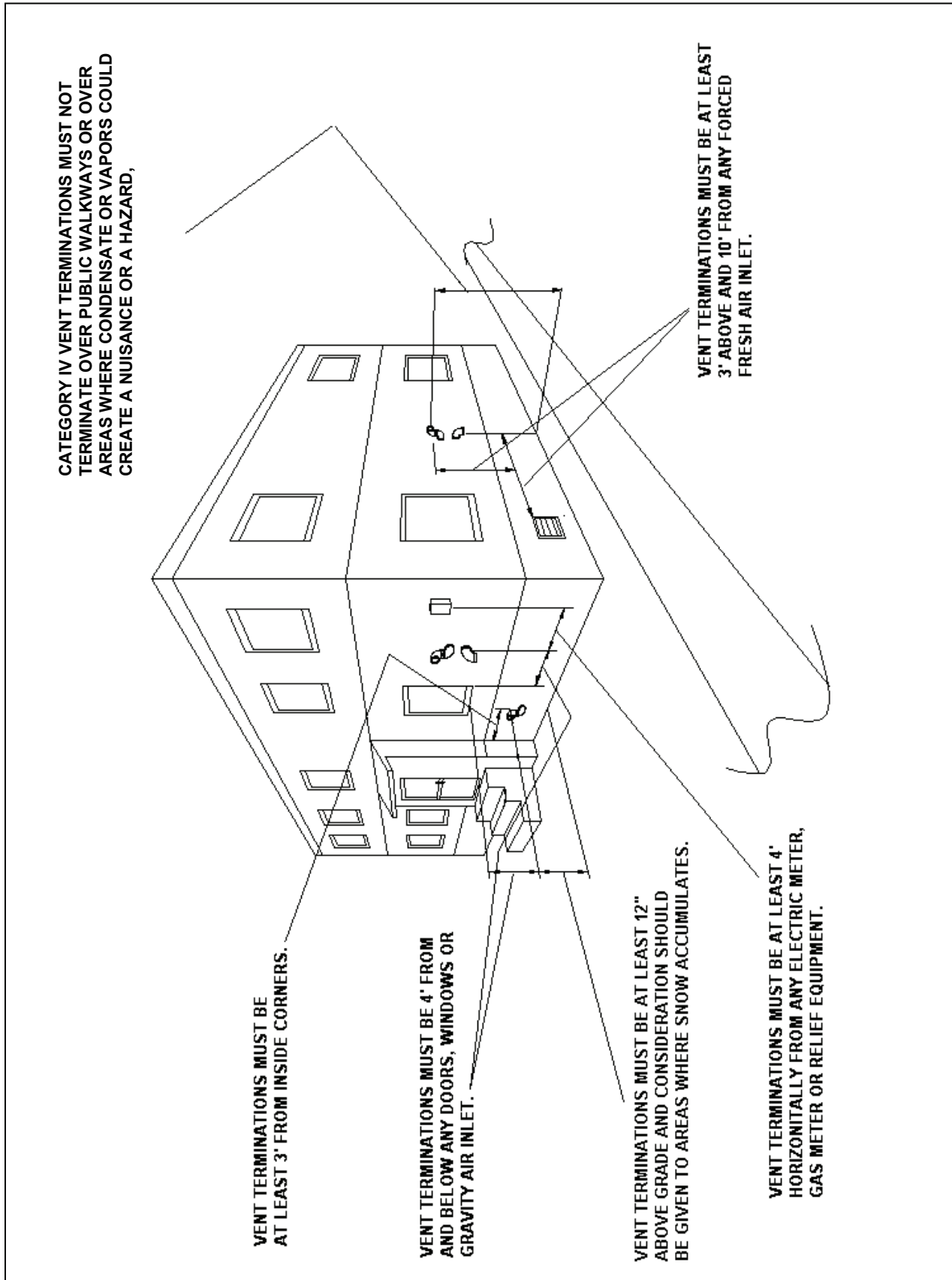

FIGURE 12

VENTING GUIDE

3.3 INSTALLATION PROCEDURE FOR VERTICAL VENTING



WARNING

DO NOT INSULATE OR OTHERWISE WRAP VENT PIPE OR FITTINGS. FOLLOW THE VENT PIPE MANUFACTURERS INSTALLATION INSTRUCTIONS FOR VERTICAL VENTING.

The Vent Termination Must Be Located As Follows:

- a. With a 0" clearance to combustible materials.
- b. Combustion air inlet must be 3 ft below any vent outlet, within 10 ft. See Figure 13.
- c. Vertical terminations shall extend at least 3 ft. (0.9 m) above the highest point where it passes through a roof of a building and at least 2 ft. (0.6 m) higher than any portion of the building within a horizontal distance of 10 ft. (3 m). Terminations that extend more than 2 ft above the roof must be laterally supported.
- d. Combustion air inlet must also face away from the vent outlet see Figure 13.
- e. Use vent pipe manufacturers vent cap, fire stop, support collar, roof flashing, and storm collar.

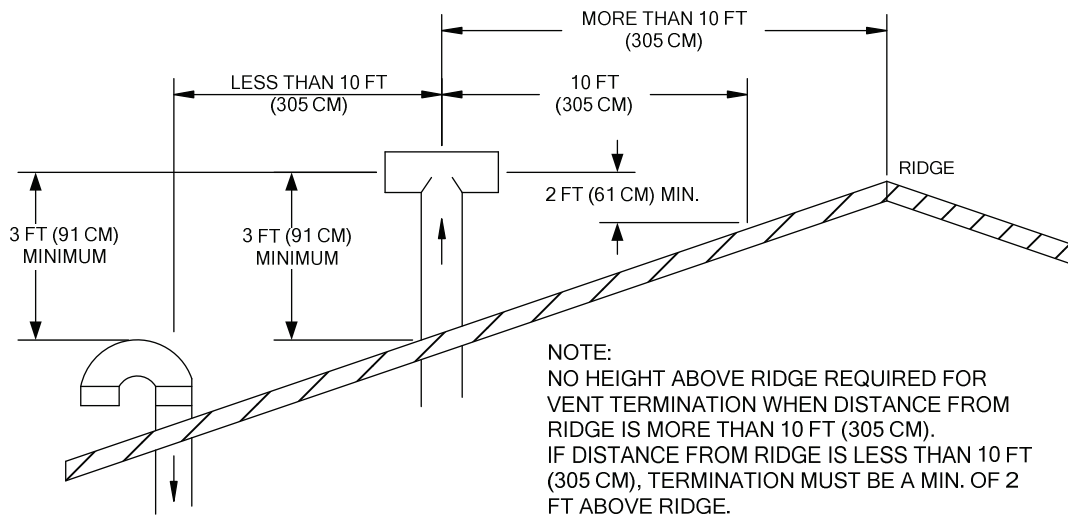

FIGURE 13

3.4 VENT PIPE SIZING

The maximum length is the combined length of straight horizontal and vertical runs, and the equivalent straight length of fittings. The required lengths for each boiler are as follows:

Model No.	MLX-303	MLX-454	MLX-606	MLX-757	MLX-909	MLX-1060
Number of Modules	2	3	4	5	6	7
Vent Diameter	4" (102 mm)	4" (102 mm)	4" (102 mm)	6 (152 mm)	6 (152 mm)	6 (152 mm)
Maximum Vent Equivalent Feet (Meters)	100 ft. (30.5 m)	100 ft. (30.5 m)	100 ft. (30.5 m)	100 ft. (30.5 m)	100 ft. (30.5 m)	100 ft. (30.5 m)

Model No.	Vent Pipe Diameter	Equivalent Vent Length Examples				Maximum Length Equiv. Ft (m)
		Sharp 90° Elbow Equiv. Ft. (m)	Sweep 90° Elbow Equiv. Ft. (m)	45° Elbow Equiv. Ft. (m)	Termination Tee; Rain Cap Equiv. Ft. (m)	
MLX-303 MLX-454 MLX-606	4" (102 mm)	10 ft. (3.05 m)	5 ft. (1.5 m)	5 ft. (1.5 m)	5 ft. (1.5 m)	100 ft. (30.5 m)
MLX-757 MLX-909 MLX-1060	6" (152 mm)	10 ft. (3.05 m)	N/A	5 ft. (1.5 m)	5 ft. (1.5 m)	100 ft. (30.5 m)

The maximum pressure drop of the combustion air piping is also 100 equivalent feet (30.5 m). See Section 2.2. Note that this does **NOT** mean the allowed combined pressure drop between the vent and combustion air is 200 equivalent feet (61 m). That is, the vent cannot go above 100 equivalent feet (30.5 m), even if the combustion air is less than 100 equivalent feet, and vice versa.

Examples:

1. A 40 foot (12.2 m) length of vent pipe and 1 sharp 90° elbow add up to 40 ft + 10 ft = 50 equivalent ft. (15.2 m)
2. A 30 foot (10.4 m) length of vent pipe and 2 sharp 90° elbows add up to 30 ft + (2 x 10 ft) = 50 equivalent ft (15.2 m)

VENTING GUIDE

3.5 COMMON VENT PIPE SIZING

Refer to Figures 9 and 10 in Section 2 for typical common vent installations. The maximum length is the sum of the equivalent straight length of horizontal runs, vertical runs, and fittings of the individual vent connector and the common vent pipe. The maximum length is the combined length of straight horizontal and vertical runs, and the equivalent straight length of fittings. The required diameter for a given Modulex total BTU/hr Input are as follows:

Total BTU/hr Input (up to and including)	606,000	1,212,000	2,120,000	3,180,000
Common Vent Diameter	4" (102 mm)	6" (152 mm)	8" (203 mm)	10" (254 mm)
Maximum Vent → Individual Connector <u>plus</u> Common Vent Equivalent Feet (Meters)	100 (30.5 m)	100 (30.5 m)	100 (30.5 m)	100 (30.5 m)

Total BTU/hr Input (up to and including)	Common Vent Diameter	Equivalent Common Vent Lengths Examples				Maximum Length → Individual Connector <u>plus</u> Common Vent Equivalent Ft (m)
		Sharp 90° Elbow Equiv. Ft (m)	Sweep 90° Elbow Equiv. Ft (m)	45° Elbow Equiv. Ft (m)	WYE Equiv. Ft (m)	
606,000	4" (102 mm)	10 ft. (3.05 m)	5 ft. (1.5 m)	5 ft. (1.5 m)	5 ft. (1.5 m)	100 ft. (30.5 m)
1,212,000	6" (152 mm)	10 ft. (3.05 m)	N/A	5 ft. (1.5 m)	5 ft. (1.5 m)	100 ft. (30.5 m)
2,120,000	8" (203 mm)	10 ft. (3.05 m)	N/A	5 ft. (1.5 m)	5 ft. (1.5 m)	100 ft. (30.5 m)
3,180,000	10" (254 mm)	10 ft. (3.05 m)	N/A	5 ft. (1.5 m)	5 ft. (1.5 m)	100 ft. (30.5 m)

NOTES:

- The chart above shows equivalent pipe lengths of the fittings for the common vent pipe. See section 3.4 for equivalent lengths for fittings for the individual boiler connector.
- The maximum equivalent length shown is the sum of the equivalent length of the longest individual connector plus the equivalent length of the common vent pipe. **If the maximum equivalent length exceeds 100 equivalent ft, contact your AERCO sales representative or AERCO International for design assistance and approval.**
- It is important to use a WYE as a means to connect the individual vent into the common vent pipe. This will ensure the least amount of pressure drop. Do NOT use a TEE, 90°, or 45° elbow.

The maximum pressure drop of the combustion air piping is also 100 equivalent feet (30.5 m). See Section 2.3. Note that this does **NOT** mean that the allowed combined pressure drop between the vent and combustion air is 200 equivalent feet (61 m). That is, the vent cannot go above 100 equivalent feet (30.5 m), even if the combustion air is less than 100 equivalent feet, and vice versa.

VENTING GUIDE

Example:

The vent system of two MLX-757 (2 x 757,000 BTU/hr = 1,514,000 BTU/hr) consists of 30 foot length of vent pipe and 2 sharp 90° elbows. Each individual vent connector consists of 5 ft straight run and one WYE.

Common Vent pipe: $30 \text{ ft} + (2 \times 10\text{ft}) = 50$ equivalent ft (15.2 m)

Individual vent connector: $5 \text{ ft} + 5 \text{ ft} = 10$ equivalent ft (3.0 m)

Total Vent equivalent length: $50 \text{ ft} + 10 \text{ ft} = 60$ (18.2 m)

60 equivalent ft is LESS than 100 equivalent feet: OK to use 8" Common vent piping and 6" individual connectors.

AERCO INTERNATIONAL INC.
159 PARIS AVENUE NORTHVALE, N.J. 07647 –
PHONE 201-768-2400 FAX 201 784-8073

AERCO declines every responsibility for the possible inaccuracies if owed to errors of transcript or press. Also, AERCO reserves the right to bring those changes that will hold necessary to its own products or profits, without jeopardizing its essential characteristics.

