

**DRISTEEM**<sup>®</sup>  
The humidification experts

**Ultra-sorb<sup>®</sup> Model XV**

Steam Dispersion Panel

**Installation, Operation,  
and Maintenance Manual**



*For pressurized steam applications*

# Table of contents

---

## **WARNING!**

Steam humidification systems have extremely hot surfaces.

To avoid burns, allow humidifier, steam pipes, and dispersion assemblies to cool before touching any part of the system.

---

## **ATTENTION INSTALLER**

Read this manual before installing. Leave manual with product owner.

## **DRI-STEEM technical support**

800-328-4447

## **Field assembly**

Unpack the dispersion assembly and loose components	3
Verify that the order is complete	3
Lay out the panel components	4
Attach the flanges	4
Attach the top frame assembly	4
Tighten the flange locknuts	4
Install the dispersion tubes	4

## **Installation**

Panel and piping components	5
Selecting the location	6
Installation in a cold air stream	7
Placement upstream of an elbow or duct split	7
Installation above valuable equipment	7
Recirculation unit	7
Panel support	7
Dispersion tube orientation	8
Mounting in a duct	8
Duct smoke detector	8
Mounting in an air handling unit	9
Trap recommendation	10
Recommendations for steam absorption	10
Steam and condensate connections	10
Header overflow P-trap water seal	10
Preventing duct static pressure loss	11
Lifting condensate	11
Temperature switch	12
Heat exchanger shut-off delay	12

<b>Start-up and operation</b>	13
-------------------------------	----

<b>Performance data</b>	14
-------------------------	----

## **Maintenance**

Strainer	15
Steam traps	15
Header overflow P-trap water seal	15
Valves	15
Dispersion tubes	15
Heat exchanger	16

<b>Replacement parts</b>	17
--------------------------	----

<b>Troubleshooting</b>	18
------------------------	----

<b>Warranty</b>	20
-----------------	----

---

## Field assembly

### Unpack the dispersion assembly and loose components

- Ultra-sorb Model XV has high-efficiency dispersion tubes. The tubes are insulated with polyvinylidene fluoride (PVDF) insulation, which provides up to an 85% reduction in wasted energy by significantly reducing airstream heat gain and condensate production.
- Remove shipping materials from the dispersion assembly, being careful not to bump or scrape the white PVDF dispersion tube insulation
- Do not lay dispersion tubes (if shipped loose by request or by shipping necessity) across or under anything that could compress or damage the insulation. Compressing insulating material may reduce its R-value.
- Avoid bumping or snagging the PVDF insulation. Although PVDF is robust, rough handling can cause tears, which could negatively impact performance.
- Before start-up, remove the clear poly film by tearing it along the perforation. **Do not use a knife or sharp object to remove the poly film. Do not remove the white PVDF insulation.**

### Verify that the order is complete

Verify that all panel and piping components are included in the delivery. Check the packing list, and see Tables 4-1 and 5-1.

### Integral heat exchanger

- Ultra-sorb Model XV employs an integral heat exchanger to pressurize and lift condensate up to 12" per psi (300 mm per 6.9 kPa) of steam pressure.
- Steam pressure entering the heat exchanger must be at least 5 psig (35 kPa).
- Condensate may be piped to the condensate return main.

---

## CAUTION!

The dispersion tubes are sleeved in clear poly film for protection during processing, shipping, and installation.

Leave the clear poly film on until installation is complete so the insulation stays clean.

Equally important, remove and discard the clear poly film before start-up by tearing it along the perforations. **Do not remove the white PVDF insulation.**



- Keep the flame away from the insulating material to avoid damage.
- PVDF is inherently resistant to UV light. Indirect, low-intensity UV-C light from germicidal lamps will not cause the insulating material to degrade.
- Do not tighten mounting clamps or fasteners to any part of the dispersion tube.

## Field assembly

**Note:** These assembly instructions are for Ultra-sorb Model XV panels shipped unassembled by request or as required. Panels with overall height more than 98" (2490 mm) are shipped unassembled.

**Table 4-1:  
Model XV panel components**

Component	Qty.
Header assembly	1
Dispersion tube	Varies
Top frame assembly	1
Flanges	2
Panel fasteners	8
Flange locknuts	8

### Lay out the panel components

Orient the panel components on a large, flat working surface.

### Attach the flanges

Guide the flanges onto the threaded studs of the header assembly, and start the locknuts onto the threads finger-tight.

### Attach the top frame assembly

Span the flanges with the top frame assembly. Align the locating buttons on the flanges and top frame, and push the eight panel fasteners into place.

**Note:** Compress the toggles to remove a panel fastener.

### Tighten the flange locknuts

Torque the eight flange locknuts to 16 ft-lb (22 N-m) at 100 rpm maximum using a 7/16" deep-well socket.

### Install the dispersion tubes

**Note:** Do not remove the poly film from the dispersion tubes until after the panel is installed.

Ensure that each dispersion tube has the seal and spring in place (see Figure 5-2). Push the dispersion tube plug end into the top frame hole to compress the spring. Seat the seal end in the corresponding header hole on the bottom. Rotate the dispersion tubes so the tubelets discharge steam perpendicular to the airstream. See Figure 8-1.

**Figure 4-1:  
Model XV components**

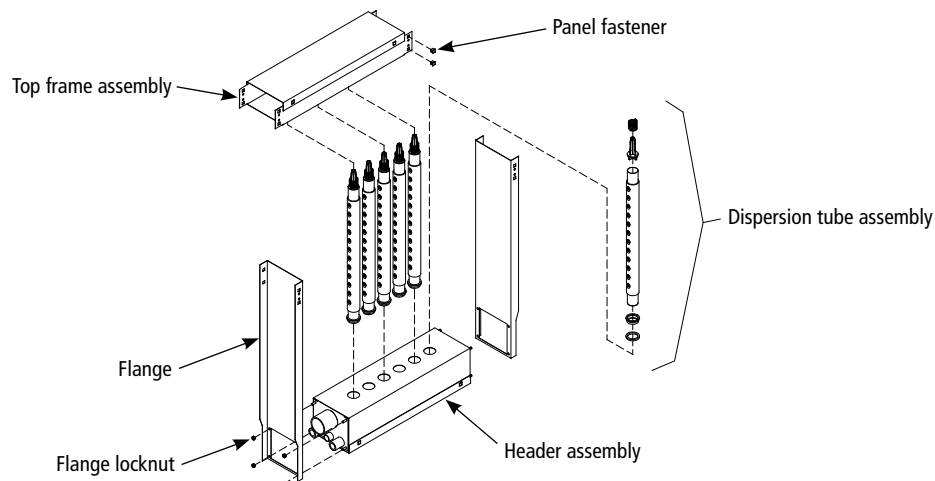

OM-7484

# Installation

## Panel and piping components

The Ultra-sorb Model XV dispersion panel and piping components are shown in Figure 5-1.

Panel location choices, installation instructions, and system options are provided in the following subsections.

Component	Qty.
Modulating steam valve	1
On/Off valve for pressurized steam input	1
Temperature switch	1
Inlet strainer	1
Float & thermostatic (F&T) trap	1

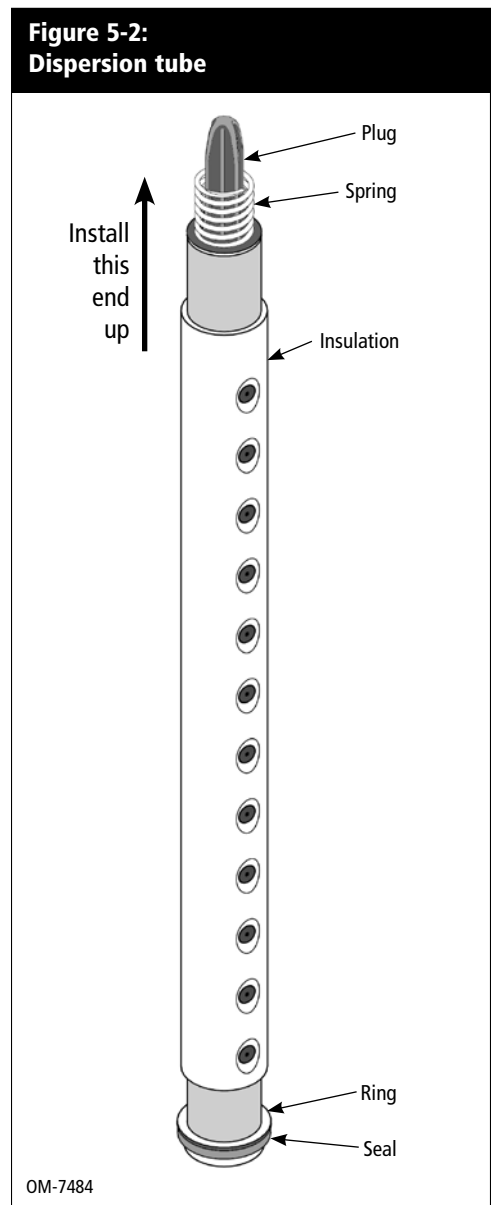
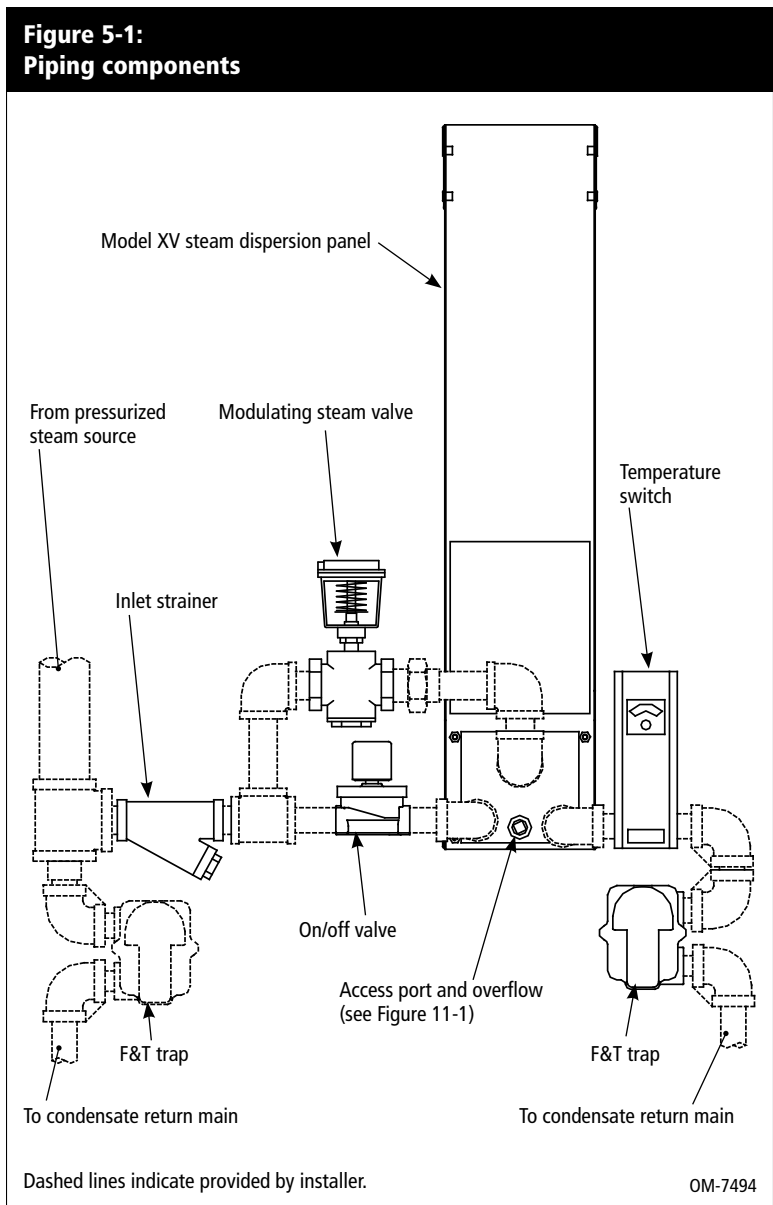

# Installation

## Panel placement in an air handling unit (see Figure 6-1)

- **Location A is the best choice.**  
Installing downstream of heating and cooling coils provides laminar flow through the dispersion unit; plus, heated air provides an environment for best absorption.
- **Location B is the second-best choice.**  
However, in change-over periods, the cooling coil will eliminate some moisture for humidification.
- **Location C is the third-best choice.**  
Air leaving a fan is usually very turbulent and can cause vapor to not absorb at the expected absorption distance. Allow for more absorption distance if installing downstream of a fan.
- **Location D is the poorest choice.**  
The cooler air at this location requires an increased absorption distance.

## Selecting the location

DRI-STEEM has cataloged the distance unabsorbed steam travels in an airstream (see Figure 14-1). Dispersed steam must be absorbed into the airflow before it comes in contact with duct elbows, fans, vanes, filters, or any object that can cause condensation and dripping.

- Install the Ultra-sorb panel in a location where discharged water vapor being will be absorbed by the airstream.
- In general, place the Ultra-sorb panel where the air temperature is capable of absorbing discharged steam without causing condensation at or after the unit. This will normally be downstream of the heating coil where the air is warmest.
- Do not place the Ultra-sorb panel in an outside air intake unless the air is tempered with a preheat coil.
- Do not place the Ultra-sorb panel near the entrance of a high-efficiency filter. The filter will remove visible moisture and become waterlogged. See the CAUTION about absorption (non-wetting) distance in the *Performance data* section.
- Do not place the Ultra-sorb panel where discharged visible mist will impinge directly on a metal surface.

**Figure 6-1:**  
**Placing a dispersion assembly in an AHU**

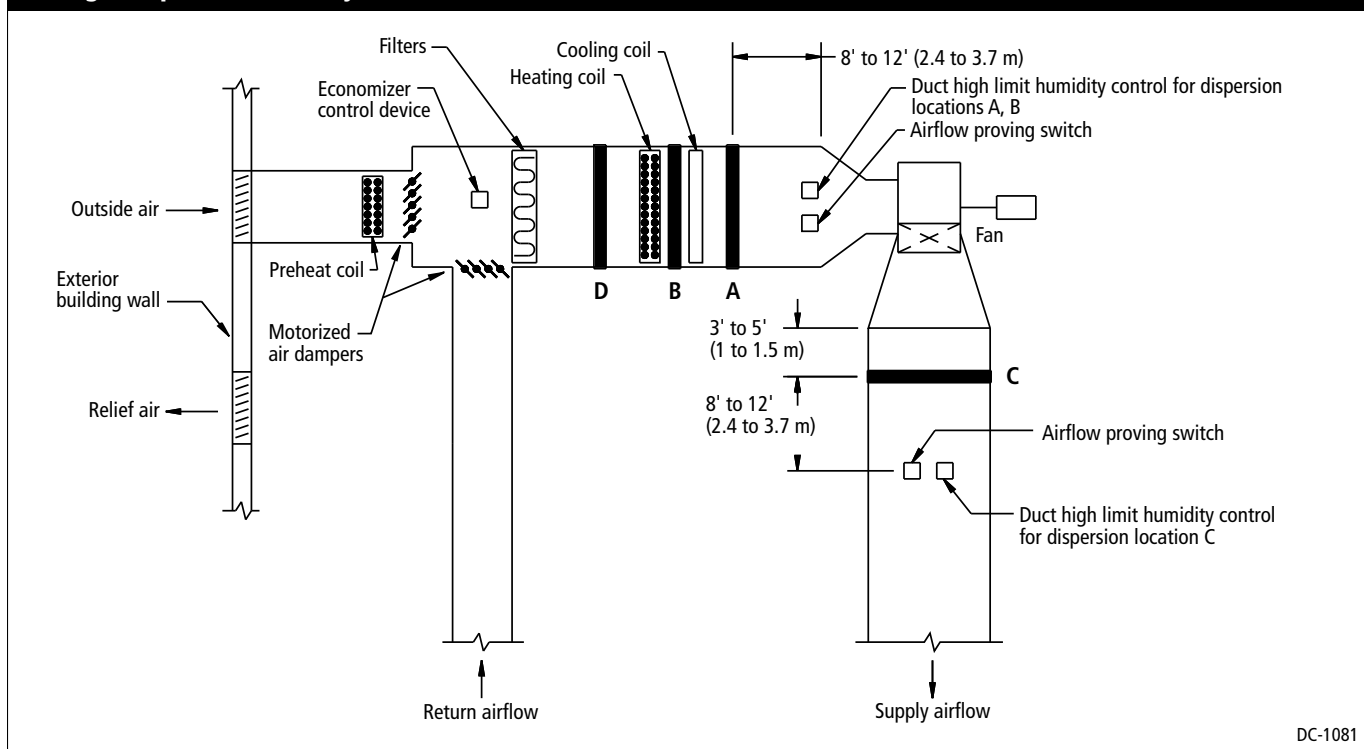

DC-1081

# Installation

## Installation in a cold air stream

When a humidifier is installed in a duct that will carry cold air, determine the dew point temperature. If the psychrometric chart reveals that saturation may occur, protection should be provided. A high-limit humidistat or thermostat set to cut off the humidifier at a safe temperature can be used for this purpose. See Figure 7-2.

## Placement upstream of an elbow or duct split

Due to Ultra-sorb's rapid steam absorption performance, installation upstream from elbows or duct splits can be done with confidence. See Figure 7-3.

## Installation above valuable equipment

Water piping and humidifiers should not be installed above expensive equipment. A condensing or leaking water pipe or other accidental water spillage could cause serious damage to the equipment below. When such an installation cannot be avoided, install a galvanized drip pan under the humidifier piping, valve, etc. to catch and drain away unintended water. See Figure 7-4.

See the *Header overflow P-trap water seal* section.

## Recirculation unit

In applications where no duct system exists, or if the air is too cool for proper humidity absorption, a recirculation fan can be used. The fan circulates room temperature air across the humidifier and discharges humidified air into the space. Select the air discharge point carefully to avoid condensation on building or equipment surfaces. See Figure 7-1.

## Panel support

The duct or air handler section and Ultra-sorb panel must be properly supported to carry the weight of the assembly. The weight of the piping must be supported by the building structure rather than by the Ultra-sorb unit. Otherwise, the weight may impose stress on the connections, causing them to fracture and leak.

**Figure 7-1:**  
Recirculation unit

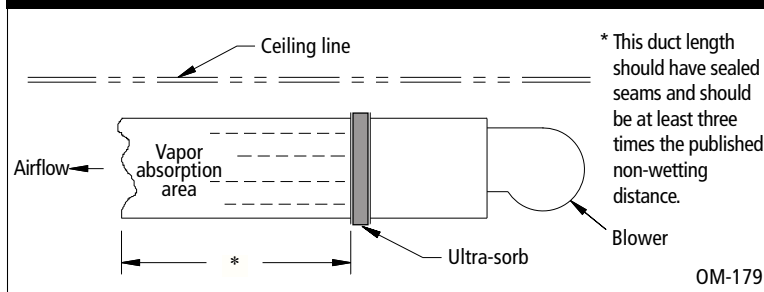

OM-179

**Figure 7-2:**  
Installation in a cold air stream

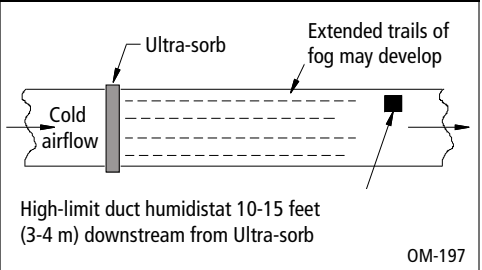

OM-197

**Figure 7-3:**  
Upstream placement

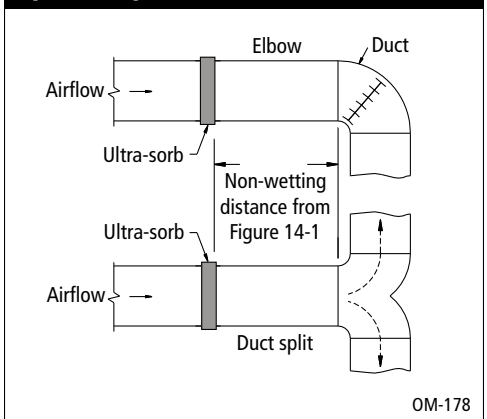

OM-178

**Figure 7-4:**  
Installation above valuable equipment

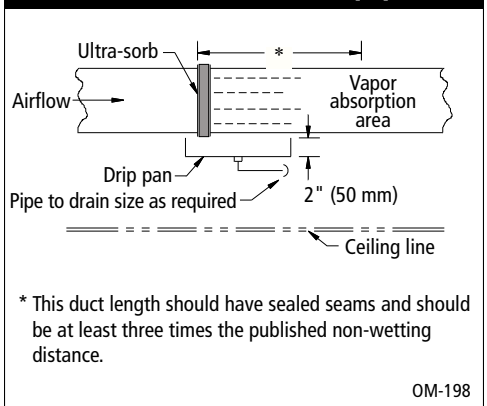

OM-198

# Installation

## Duct smoke detector

Do not install a duct smoke detector downstream from the Ultra-sorb panel. If downstream installation is required, install it far enough from the Ultra-sorb panel to avoid false alarms.

**Figure 8-3:**  
Preventing duct static pressure loss

Ultra-sorb panels that penetrate a duct section must be sealed with HVAC caulking or a similar weather sealant to prevent air leakage.

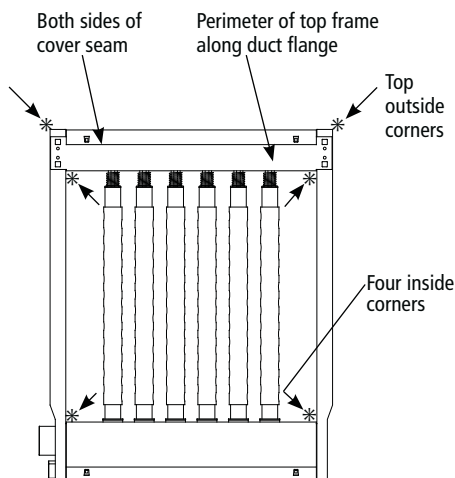

OM-7483

## Dispersion tube orientation

Verify that the steam discharge tubelets are perpendicular to the airstream (see Figure 8-1). The spring-loaded dispersion tubes easily rotate for proper orientation.

**Figure 8-1:**  
Dispersion tube orientation

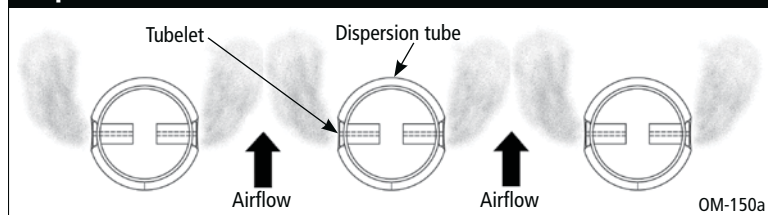

## Mounting in a duct

To avoid puncturing the header, screw penetration into the header assembly must not exceed  $\frac{3}{4}$ " (20 mm).

The Model XV panel is designed for horizontal airflows only. Mounting flanges on both sides of the unit and the header and frame can be used as mounting surfaces (see Figure 8-2). A matching flange or metal frame is required on the ductwork for connection to the Ultra-sorb flanges. The recommended fastener is a #12 self-drilling and tapping screw  $\frac{3}{4}$ " (20 mm) long, spacing not to exceed 12" (305 mm). If an angle-iron frame is provided on the duct section, a longer screw may be required.

**Figure 8-2:**  
Model XV in a duct

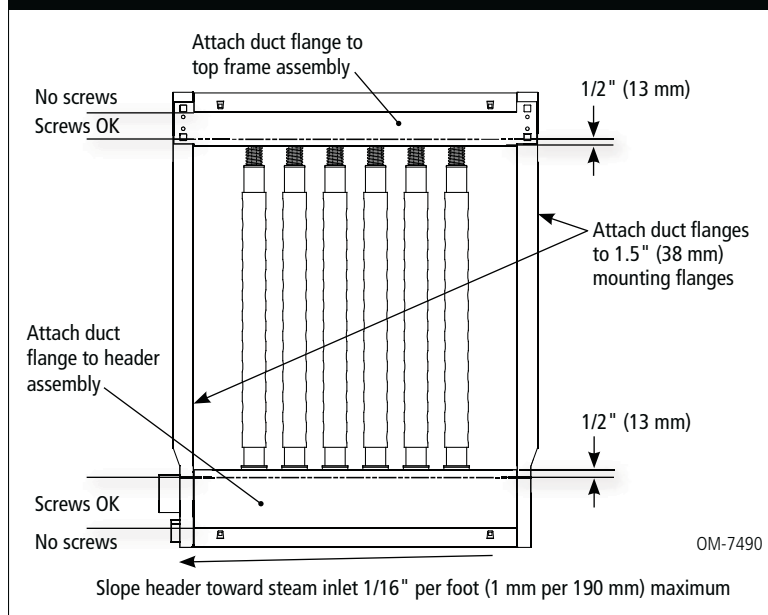

# Installation

## Mounting in an air handling unit

Model XV must be used in pressurized steam applications and in horizontal airflows only, as shown in Figure 9-1.

Metal support frames should be anchored to the air handler casing. Recommended fasteners for mounting the Ultra-sorb to a metal support frame are ¼ - 20 nuts and bolts or #12 self drilling and tapping screws.

Due to possible forces exerted on this application, DRI-STEEM recommends fastener spacing not to exceed 6" (150 mm).

**Figure 9-1:**  
**Model XV in an air handler**

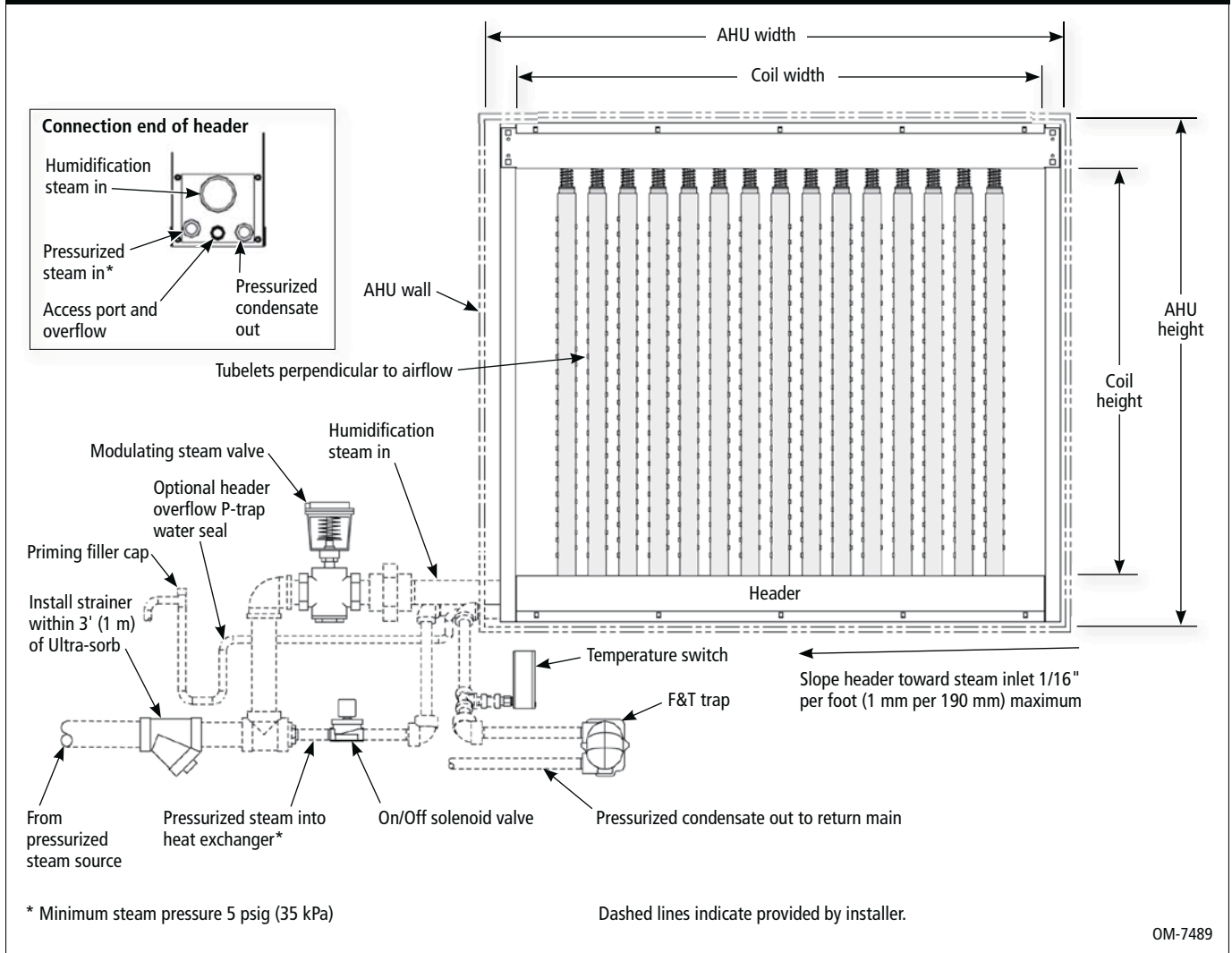

## Installation

### Trap recommendation

The steam supply line should be dripped immediately ahead of the steam valve through a steam trap.

Low pressure, up to 15 psi (103 kPa) — F&T trap

High pressure, more than 15 psi (103 kPa) — Inverted bucket trap

Install a wye strainer ahead of the steam valve (see Figure 10-1).

### Recommendations for steam absorption

To ensure driest steam, take humidifier steam off the top of the steam main (not the side or bottom).

An airflow proving switch is recommended to prevent the steam valve from opening if air is not moving in the duct.

To prevent over saturation when duct air is cooler than 70 °F (21 °C), a high-limit (duct mounted) humidistat at least 15 feet (4.5 m) downstream and set at 80-90% is recommended.

### Steam and condensate connections

Use a back-up wrench when tightening connections onto any Ultra-sorb threads (see Figure 10-2).

#### Humidification steam inlet

Because the heat exchanger vaporizes all dispersion tube-generated condensate, all steam entering the humidification steam inlet exits the tubelets and is dispersed in the airstream.

#### Pressurized boiler steam inlet

Steam pressure entering the heat exchanger must be least 5 psig (35 kPa) to vaporize condensate in the header.

#### Pressurized condensate outlet

Condensate exiting the heat exchanger is piped to the condensate return main. See *Lifting condensate* on the facing page.

### Header overflow P-trap water seal

Ultra-sorb Model XV is designed to vaporize the condensate generated in a properly designed, installed, operated, and maintained system. An optional, fail-safe header overflow installation is recommended if any of the following are true:

- Operating parameters exceed design criteria.
- Boiler chemicals are causing heavy material deposition on the heat exchanger (see *Heat exchanger* in the *Maintenance* section).
- System overflow prevention is critical.

**Figure 10-1:**  
**Ultra-sorb strainer**

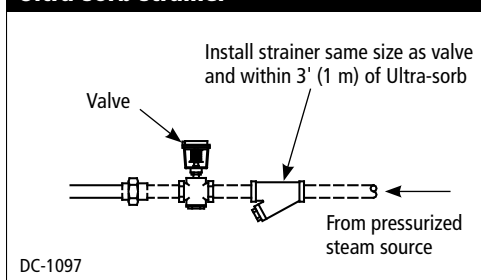

DC-1097

**Figure 10-2:**  
**Steam and condensate connections**

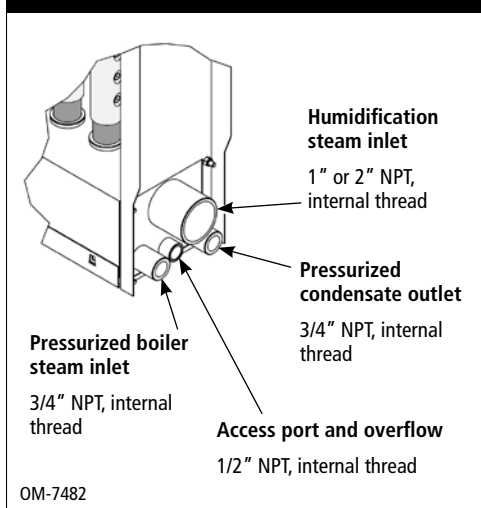

OM-7482

## Installation

- The application requires the tallest dispersion tubes, the closest tube spacing, and the lowest allowable heat exchanger steam pressures.
- Operator intervention could result in improper system settings.

The access port can be configured as a header overflow with a P-trap water seal. To install an overflow P-trap and drain line, replace the access port 1/2" NPT plug with a 1/2" NPT drain connection, and plumb the drain pipe dimensions as shown in Figure 11-1.

Before operating the Ultra-sorb, prime the P-trap with about 1 cup (200 ml) of water. During normal operation, little condensate is available to the overflow. As such, a water seal cannot be assured via condensate alone. At startup after long off periods:

- Air may be drawn into the duct via the overflow drain for some time before a water seal forms.
- Steam may blow through the overflow drain for some time before creating a water seal.

If either of these scenarios are unacceptable, prime the P-trap before seasonal startup, or feed the P-trap with a water source that assures a constant water seal.

### Lifting condensate

Theoretically, 1 psi of steam pressure will lift condensate about 28" (6.9 kPa will lift condensate about 700 mm). In practice, because of pipe friction, pressure drop through a steam trap, and back pressure in a return line, a maximum lift of 12" per psi (300 mm per 6.9 kPa) of steam pressure at the trap is recommended.

The steam trap for lifting condensate should be an inverted bucket type with a check valve on the outlet. Float and thermostatic traps, are prone to damage from water hammer often present in flooded trap conditions where condensate must be lifted.

The vertical portion of the piping should be at least 1/2" NPT.

**Figure 11-1:**  
**Header overflow P-trap water seal**

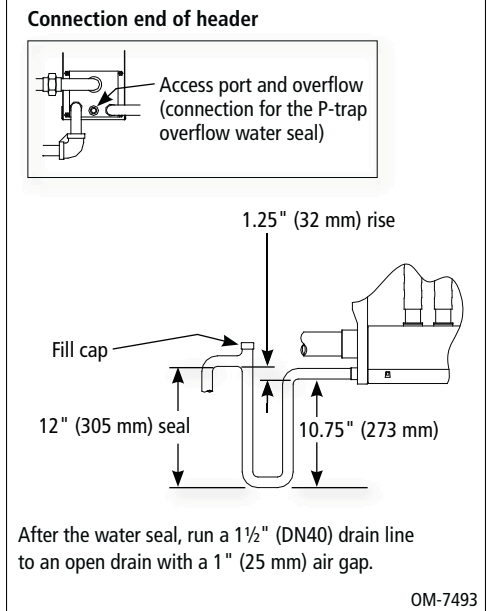

## Installation

**Figure 12-1:  
Temperature switch location**

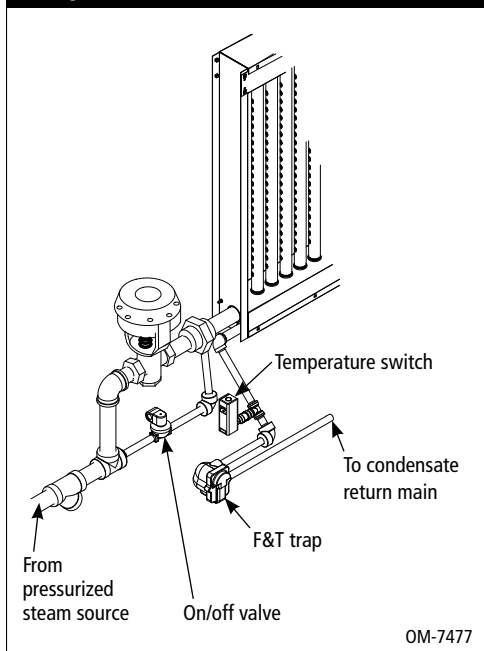

### Temperature switch

Install the temperature switch to prevent the header from flooding with condensate if the heat exchanger cools, such as if the condensate return main becomes flooded or the P-trap fails closed.

DRI-STEEM's electric temperature switch prevents the header from flooding with condensate if the heat exchanger cools by means of a temperature-actuated make-break switch designed for electric humidity control systems. The temperature at which it switches is adjustable and should be set at 210 °F (99 °C).

- Install the sensing element of the device in the condensate return piping between the Ultra-sorb heat exchanger outlet and the inlet to the steam trap, as shown in Figure 12-1. Include a tee with a ½" (DN15) pipe thread opening to receive the sensing element. When steam surrounds the sensing element, the switch will "make," allowing the humidifier valve to open.
- Install all wiring according to national and local electrical codes, and size transformer VA to load VA.
- When using the temperature switch with an electric modulating valve, use the special wiring instructions furnished with the valve.

### Heat exchanger shut-off delay

To dry the header, pressurized steam can be set to flow through the heat exchanger for a set amount of time after humidification steam stops. This time delay can be set through the building management system (BMS) or configured independent from the BMS. See the wiring diagram included with the on/off valve.

A time delay relay for configuring the time delay manually is available from your local DRI-STEEM representative.

For systems that run constantly (all day, every day, all year), there is no need for a shut-off delay.

Systems that stop humidifying for extended periods of time may have two reasons for a heat exchanger shut-off delay: to conserve energy and to remove standing water that might allow for microbe growth.

Setting the heat exchanger to remain on for 1/2 hour after humidifying stops will be adequate time to ensure complete dry-out of the dispersion system.

---

## Start-up and Operation

After removing the clear poly film from the dispersion tubes, follow the start-up instructions below.

### Start-up

1. Prime the header overflow P-trap, if installed, and ensure that it follows the recommendations in the *Header overflow P-trap water seal* section and Figure 11-1.
2. Turn on steam to the heat exchanger. Inspect connections for piping leaks.
3. Ensure that the traps are operating.
4. Turn on the modulating steam valve, and check for piping leaks.
5. Check the dispersion tubes for leaks.

**Note:** Spitting from the seal (bottom) end of a dispersion tube could be caused by a missing seal (5). See Figure 17-1.

6. Ensure that the dispersion tubes are oriented with the tubelets at a right angle to the airflow. See Figure 8-1.
7. Check for any other leaks from header connections.
8. With both heat exchanger and humidification steam turned on, turn off steam to the heat exchanger. Make sure the temperature switch turns off the modulating steam valve to stop humidification steam from entering the dispersion assembly.
9. Heat exchanger operation:
  - Ensure operating steam pressure is at least 5 psig (35 kPa).
  - Ensure on/off and shut-off delay (if using shut-off delay) conditions are working as intended.

### Operation

During operation, prevent problems by following the service time intervals and guidelines in the *Maintenance* section. See Table 18-1 for troubleshooting.

---

**Do not remove the white PVDF insulation.**

Tear the clear poly film along the perforations, and remove and discard it before start-up.



## Performance data

**Table 14-1:  
Model XV air pressure loss**

Duct air velocity (55 °F [13 °C] at sea level)		Tube spacing			
		3"	75 mm	6"	150 mm
fpm	m/s	wc	Pa	wc	Pa
500	2.54	0.033	8.3	0.005	1.3
1000	5.08	0.121	30.2	0.020	5.1
1500	7.62	0.237	59.2	0.046	11.5

**Notes:**

- Ultra-sorb panels with 9" (225 mm) or 12" (300 mm) tube spacings have no measurable air pressure loss.
- Use DRI-STEEM's Dri-calc sizing and selection software to calculate your specific air pressure loss.

1. Non-wetting distance is the distance downstream from the Ultra-sorb panel after which wetting will not occur. Although steam wisps may be present, solid objects at duct air temperature, such as coils, dampers, fans, etc., downstream from this point will remain dry.
2. See Figure 14-1. Note that the rise in RH ( $\Delta$ RH) between entering and leaving air has a direct bearing on the non-wetting distance. As the  $\Delta$ RH increases, more vapor needs to be dispersed into the air; thus, the non-wetting distance increases.
3. **CAUTION!** Non-wetting distances described here do not apply when installing an Ultra-sorb panel upstream of filter media. If you must install an Ultra-sorb panel upstream of filter media, consult DRI-STEEM or your local DRI-STEEM representative for special recommendations.
4. Uneven airflow over the Ultra-sorb panel cross-section may result in nonuniform mixing of steam with air, which may adversely affect absorption distance.
5. A small but measurable amount of duct air pressure loss will be present downstream from the Ultra-sorb panel, depending on air density, velocity, and tube spacing. See Table 14-1.

**Figure 14-1:  
Ultra-sorb non-wetting distances**

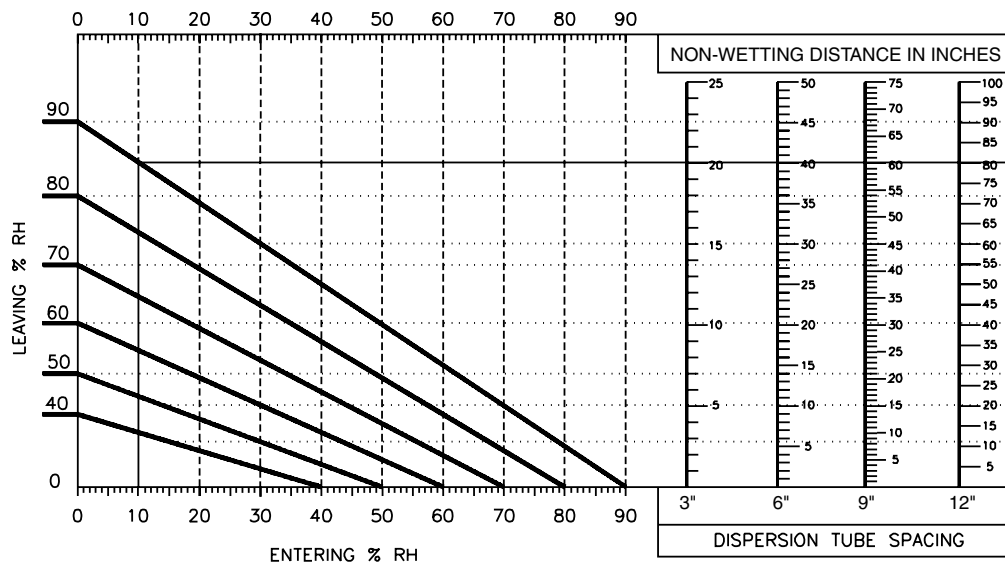

**Note:**

The above non-wetting data apply to air velocities up to 2000 fpm (10.2 m/s) and are based on air leaving the humidification zone at of 55 °F (13 °C) and the stated % RH.

---

# Maintenance

## Strainer

Inspect at least twice during the first year. If fouled, inspect it more frequently.

## Steam traps

At least twice a year verify that the steam traps are functioning properly. A blocked steam trap is room temperature. A “blowing” steam trap is hot and noisy, and the discharge pipe from it is hot for 30 feet (9 m). A properly operating steam trap is hot and makes noise at intervals, and the discharge pipe is progressively cooler beginning at the trap.

## Header overflow P-trap water seal

If this option is used (see *Header overflow P-trap water seal* in the *Installation* section): Prime the P-trap with about 8 ounces (about 200 ml) of water whenever the panel has been idle for 90 days or more.

## Valves

- Pneumatic: Inspect annually to be sure the valve tightly closes off steam, the stem packing is not leaking steam, and the actuator diaphragm is not leaking air.
- Electric modulating: Inspect annually to be sure the valve operates freely and closes off steam tightly and the stem packing is not leaking.
- Solenoid type: Inspect annually to verify proper functioning with steam-tight shut off.

## Dispersion tubes

- If steam or condensate is evident at the sealing surface, replace the seal.
- Inspect insulating material for tears; repair with Insulating Material Repair Kit (available from your local DRI-STEEM representative) before dispersing steam or moving air through the air handler to prevent further damage. This kit uses tested and proven PVDF as repair material; do not use other adhesives or repair methods.
- Inspect insulating material for dirt and smudges; gently clean with damp cloth and soapy water or diluted nontoxic, biodegradable cleaner/degreaser. Do not clean insulating material with a pressure washer; direct spray could cause damage.

## Maintenance

**Figure 16-1:  
Header cross section**

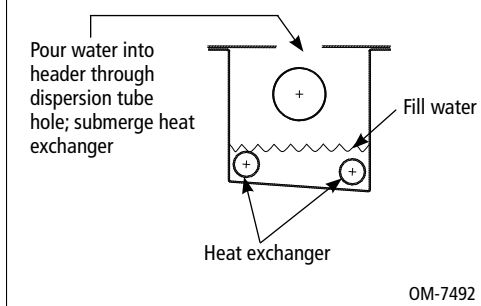

### Heat exchanger

Environmental conditions may require periodic heat exchanger cleaning. After 2000 hours of operation, remove a dispersion tube and check whether the heat exchanger is coated with material deposits. Use of boiler chemicals that result in material deposits on the heat exchanger may require more frequent inspection and cleaning to maintain proper heat exchanger operation and avoid header flooding.

Material deposits can be removed from the heat exchanger with DRI-STEEM's Humidifier De-scaling Solution, available for purchase from your DRI-STEEM representative or distributor. It is the only cleaner/de-scaler approved for use with DRI-STEEM humidifiers. Use of other cleaners/de-scalers may void your DRI-STEEM warranty. See DRI-STEEM's Humidifier De-scaling Solution page at [www.dristeem.com](http://www.dristeem.com), or [click here](#).

The *Usage Instructions* shipped with the DRI-STEEM Humidifier De-scaling Solution contain important handling, mixing, timing, and pH testing information.

---

### **WARNING!**

**Read and follow all warnings and instructions shipped with the DRI-STEEM Humidifier De-scaling Solution.**

---

**The following additional instructions are for Ultra-sorb Model XV:**

- Before pouring water or de-scaling solution into the header, install a 1/2" NPT thread drain hose in the header access overflow port. After making sure the hose can reach a bucket or drain, elevate the end well above the connection.
- Remove a dispersion tube, and add water to the header to submerge the heat exchanger (see Figure 16-1).
- Add 10 ounces of de-scaling solution per foot of header length (30 ml of de-scaling solution per 300 mm of header length). A 12-foot (3660 mm) header requires about 1 gallon (3.8 litres) of de-scaling solution.
- After performing the de-scaling procedure as described in the *Usage Instructions*: Before resuming operation, flush and drain the header four times to thoroughly remove de-scaling solution from the system.

# Replacement parts

**Table 17-1:  
Model XV Replacement parts**

No.	Description	Part No.
1	Panel fastener, frame (package of 4)	191170-010
2	O-ring, square 1.35" ID (package of 10)	191170-015
3	Ring, tube end, 1.5" (package of 1)	207010-001
	Ring, tube end, 1.5" (package of 5)	191170-020
4	Spring, compression, SST (package of 1)	501460-001
	Spring, compression, SST (package of 5)	191170-025
5	Plug, tube end, 1.5" (package of 1)	310260
	Plug, tube end, 1.5" (package of 5)	191170-030
6	Dispersion tube assembly	consult factory
7	Flange, side	consult factory
8	Frame assembly, top	consult factory
9	Header assembly	consult factory
10	Nut, 1/4-20 (package of 4)	191170-035
11	HVAC sealant for duct section applications (not shown)	consult factory

**Table 17-2:  
Replacement components**

Description	Part No.
Modulating steam valve	consult factory
On/Off valve body	501750-001
On/off valve coil	501700-002
Temperature switch	400260-001
Inlet strainer	consult factory
F&T trap	consult factory

**Figure 17-1:  
Model XV replacement parts**

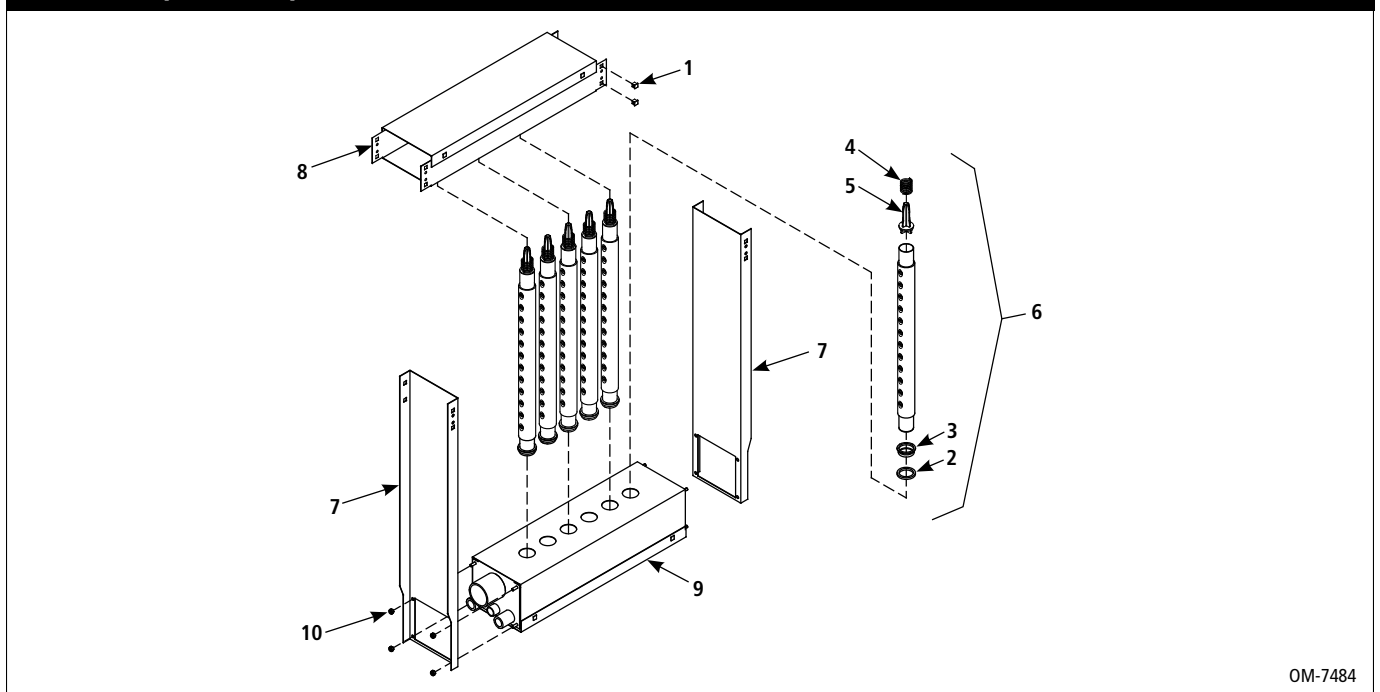

OM-7484

# Troubleshooting

**Table 18-1:  
Model XV troubleshooting guide**

Problem	Possible cause	Action
Humidifier discharges water in duct	<ul style="list-style-type: none"> <li>Missing or torn seal</li> </ul>	<ul style="list-style-type: none"> <li>Replace seal.</li> </ul>
	<ul style="list-style-type: none"> <li>Dispersion tube not properly installed</li> </ul>	<ul style="list-style-type: none"> <li>Ensure proper installation. See Figure 5-2.</li> </ul>
	<ul style="list-style-type: none"> <li>Humidification steam is exceeding capacity per tube</li> </ul>	<ul style="list-style-type: none"> <li>Ensure humidification is 35 lbs/hr (15.8 kg/h) per tube or less.</li> </ul>
	<ul style="list-style-type: none"> <li>Steam main overloaded with water due to boiler discharging water with steam (priming)</li> </ul>	<ul style="list-style-type: none"> <li>Locate cause of priming and correct.</li> </ul>
	<ul style="list-style-type: none"> <li>Steam trap not draining properly</li> </ul>	<ul style="list-style-type: none"> <li>Replace, repair, or clean trap as required.</li> <li>If condensate return main is overloaded, find an alternative method for draining.</li> </ul>
	<ul style="list-style-type: none"> <li>Humidifier improperly piped</li> </ul>	<ul style="list-style-type: none"> <li>Correct piping as shown in Figure 5-1.</li> </ul>
	<ul style="list-style-type: none"> <li>Surges of condensate in steam supply due to condensate collecting at low, undripped point in steam main</li> </ul>	<ul style="list-style-type: none"> <li>Install drips and steam traps as required. See "Trap recommendation" on page 10.</li> </ul>
	<ul style="list-style-type: none"> <li>Inadequate steam trap capacity</li> </ul>	<ul style="list-style-type: none"> <li>Replace with larger trap.</li> </ul>
	<ul style="list-style-type: none"> <li>Pressurized condensate is being lifted too high</li> </ul>	<ul style="list-style-type: none"> <li>See "Lifting condensate" on page 11.</li> </ul>
	<ul style="list-style-type: none"> <li>Heat exchanger is caked or dirty</li> </ul>	<ul style="list-style-type: none"> <li>Flush header. See "Heat exchanger" on page 16.</li> </ul>
	<ul style="list-style-type: none"> <li>Condensate collecting in header</li> </ul>	<ul style="list-style-type: none"> <li>Increase steam pressure through heat exchanger.</li> <li>See "Header overflow P-trap water seal" on page 10.</li> </ul>
	<ul style="list-style-type: none"> <li>On/off valve upstream from heat exchanger malfunctioning or stuck in the OFF position</li> </ul>	<ul style="list-style-type: none"> <li>Replace, repair, or clean valve as required.</li> </ul>
<ul style="list-style-type: none"> <li>Temperature switch downstream from heat exchanger malfunctioning</li> </ul>	<ul style="list-style-type: none"> <li>Replace or repair switch as required.</li> </ul>	
Humidity exceeds setting of humidistat	<ul style="list-style-type: none"> <li>Automatic valve not fully closing</li> </ul>	<ul style="list-style-type: none"> <li>Foreign matter holding valve open; clean valve.</li> <li>Valve spring broken; replace spring.</li> <li>Valve steam packing too tight; loosen and/or replace packing.</li> <li>Steam pressure exceeds close-off rating of valve spring; replace actuator or valve spring with one that is compatible with the higher steam pressure.</li> <li>Valve installed backwards; re-install.</li> <li>Adjust valve linkage.</li> </ul>
	<ul style="list-style-type: none"> <li>Electric control system malfunctioning</li> </ul>	<ul style="list-style-type: none"> <li>Calibrate or replace.</li> </ul>
	<ul style="list-style-type: none"> <li>Faulty or inaccurately placed humidity controller</li> </ul>	<ul style="list-style-type: none"> <li>Replace controller or relocate per catalog recommendations.</li> </ul>
	<ul style="list-style-type: none"> <li>Poor location of control components</li> </ul>	<ul style="list-style-type: none"> <li>Relocate per catalog recommendations.</li> </ul>
	<ul style="list-style-type: none"> <li>Incompatible control components</li> </ul>	<ul style="list-style-type: none"> <li>Replace per specified recommendations.</li> </ul>
	<ul style="list-style-type: none"> <li>Automatic valve is hunting</li> </ul>	<ul style="list-style-type: none"> <li>Humidifier capacity is oversized; change to smaller valve.</li> <li>Pressure reducing valve is not accurately controlling steam pressure; repair or replace.</li> <li>Boiler pressure is swinging too widely; adjust.</li> </ul>
Control system malfunctioning	<ul style="list-style-type: none"> <li>Excessive outside air volume</li> </ul>	<ul style="list-style-type: none"> <li>Check fans, dampers, VAV, etc.</li> <li>Mixed air inlet formula:                             <math display="block">\begin{aligned} &amp; (\% \text{ outside air}) \times (\text{moisture content}) \\ &amp; + (\% \text{ return air}) \times (\text{moisture content}) \\ &amp; = \text{mixed air inlet in lbs/100 cfm (kg/100 m}^3\text{/h)} \end{aligned}</math> </li> </ul>
	<ul style="list-style-type: none"> <li>Incorrect control voltage</li> </ul>	<ul style="list-style-type: none"> <li>Replace transformer.</li> </ul>
	<ul style="list-style-type: none"> <li>Incorrect control signal</li> </ul>	<ul style="list-style-type: none"> <li>Replace components.</li> </ul>
	<ul style="list-style-type: none"> <li>Improper wiring connections</li> </ul>	<ul style="list-style-type: none"> <li>Rewire.</li> </ul>
	<ul style="list-style-type: none"> <li>Incorrect humidity sensor</li> </ul>	<ul style="list-style-type: none"> <li>Replace.</li> </ul>
<ul style="list-style-type: none"> <li>Humidity controller out of calibration</li> </ul>	<ul style="list-style-type: none"> <li>Recalibrate.</li> </ul>	

# Troubleshooting

**Table 19-1:  
Model XV troubleshooting guide (continued)**

Problem	Possible cause	Action
Air cannot absorb steam quantity being discharged	• Humidifier operates when blower is off	• Provide interlock.
	• Valve is hunting	• See "Automatic valve is hunting," on facing page.
	• Air temperature in duct too low for steam quantity being emitted	• Raise duct air temperature.
Humidifier is noisy	• Steam pressure too high	• Reduce pressure.
	• Panel is vibrating	• Tighten assembly and/or mounting hardware.
Duct loses static pressure downstream from Ultra-sorb panel	• Improper sealing where Ultra-sorb frame penetrates duct	• Seal all panel corners and all cracks between panel and ducts/flanges. See "Preventing duct static pressure loss" on page 8.
Space humidity will not rise to humidistat set point	• Steam pressure too low	• Increase.
	• Manual steam valve partially closed	• Open.
	• Strainer screen partially clogged	• Clean.
	• Boiler pressure too low	• Adjust control.
	• Pressure reducing valve not accurately controlling steam pressure	• Repair or replace.
	• Boiler pressure swinging too widely	• Adjust controls.
	• Incorrect piping	• Correct piping as shown in Figure 5-1.
	• Undersized steam piping	• Replace piping.
	• Automatic steam valve not fully opening	• Valve packing is adjusted too tightly, loosen/replace packing. • Adjust valve linkage. • Recalibrate humidistat.
	• Electric control system malfunctioning	• Change transformer.
	• Incorrect control circuit voltage	• Replace components to make all components compatible.
	• Incorrect control signal	• Replace components.
	• Improper wiring	• Rewire.
	• Incorrect humidity sensor	• Replace sensor.
	• Humidity controller out of calibration/malfunctioning	• Repair or replace.
	• Malfunctioning humidifier temperature switch not allowing humidifier valve to open	• Replace or readjust.
	• Pneumatic control system malfunctioning	• Repair or replace.
	• Obstructed air line	• Remove obstruction.
	• Malfunctioning pneumatic temperature switch	• Replace switch.
	• Air leak in actuator	• Repair or replace diaphragm.
• Compressed air pressure is too low	• Adjust pressure.	
Condensate collects in duct	• Foreign matter preventing valve from closing	• Clean or replace valve.
	• Panel is mounted too close to internal devices (dampers, turning vanes, etc.) in duct	• Move panel to a point further upstream of internal devices. See "Selecting the location" in the "Installation" section and Figure 6-1). • More dispersion tubes shortens non-wetting distance. Consult DRI-STEEM to determine the total number of tubes required.
	• Uninsulated duct passing through unheated area (low duct surface temperature)	• Insulate ductwork.

# Warranty

## Expect quality from the industry leader

For more than 40 years, DRI-STEEM has lead the industry with creative and reliable humidification solutions. Our focus on quality is evident in Ultra-sorb, which features stainless steel construction and an industry-leading two year warranty covering all parts.

## For more information

www.dristeem.com  
sales@dristeem.com

For current product information, please see the [literature section](#) of our web site: [www.dristeem.com](http://www.dristeem.com)

## DRI-STEEM Corporation

An ISO 9001: 2000 certified corporation

### U.S. Headquarters:

14949 Technology Drive  
Eden Prairie, MN 55344  
800-328-4447 or 952-949-2415  
952-229-3200 (fax)

### European office:

Marc Briers  
Grote Hellekensstraat 54 b  
B-3520 Zonhoven  
Belgium  
+3211823595 (voice)  
+3211817948 (fax)  
E-mail: marc.briers@dristeem.com

Continuous product improvement is a policy of DRI-STEEM Corporation; therefore, product features and specifications are subject to change without notice.

DRI-STEEM and Ultra-sorb are registered trademarks of DRI-STEEM Corporation and are filed for trademark registration in Canada and the European community.

Ultra-sorb is covered by the following Patents, with additional patents pending: United States Patent numbers 5,126,080; 5,277,849; 5,372,753; 5,376,312; 5,543,090

© 2008 DRI-STEEM Corporation

## Two-year Limited Warranty

DRI-STEEM Corporation (“DRI-STEEM”) warrants to the original user that its products will be free from defects in materials and workmanship for a period of two (2) years after installation or twenty-seven (27) months from the date DRI-STEEM ships such product, whichever date is the earlier.

If any DRI-STEEM product is found to be defective in material or workmanship during the applicable warranty period, DRI-STEEM’s entire liability, and the purchaser’s sole and exclusive remedy, shall be the repair or replacement of the defective product, or the refund of the purchase price, at DRI-STEEM’s election. DRI-STEEM shall not be liable for any costs or expenses, whether direct or indirect, associated with the installation, removal or reinstallation of any defective product. The Limited Warranty does not include cylinder replacement for electrode steam humidifiers.

DRI-STEEM’s Limited Warranty shall not be effective or actionable unless there is compliance with all installation and operating instructions furnished by DRI-STEEM, or if the products have been modified or altered without the written consent of DRI-STEEM, or if such products have been subject to accident, misuse, mishandling, tampering, negligence or improper maintenance. Any warranty claim must be submitted to DRI-STEEM in writing within the stated warranty period. Defective parts may be required to be returned to DRI-STEEM.

DRI-STEEM’s Limited Warranty is made in lieu of, and DRI-STEEM disclaims all other warranties, whether express or implied, including but not limited to any IMPLIED WARRANTY OF MERCHANTABILITY, ANY IMPLIED WARRANTY OF FITNESS FOR A PARTICULAR PURPOSE, any implied warranty arising out of a course of dealing or of performance, custom or usage of trade.

DRI-STEEM SHALL NOT, UNDER ANY CIRCUMSTANCES BE LIABLE FOR ANY DIRECT, INDIRECT, INCIDENTAL, SPECIAL OR CONSEQUENTIAL DAMAGES (INCLUDING, BUT NOT LIMITED TO, LOSS OF PROFITS, REVENUE OR BUSINESS) OR DAMAGE OR INJURY TO PERSONS OR PROPERTY IN ANY WAY RELATED TO THE MANUFACTURE OR THE USE OF ITS PRODUCTS. The exclusion applies regardless of whether such damages are sought based on breach of warranty, breach of contract, negligence, strict liability in tort, or any other legal theory, even if DRI-STEEM has notice of the possibility of such damages.

By purchasing DRI-STEEM’s products, the purchaser agrees to the terms and conditions of this Limited Warranty.

## Extended warranty

The original user may extend the term of the DRI-STEEM Limited Warranty for a limited number of months past the initial applicable warranty period and term provided in the first paragraph of this Limited Warranty. All the terms and conditions of the Limited Warranty during the initial applicable warranty period and term shall apply during any extended term. An extended warranty term of an additional twelve (12) months or twenty four (24) months of coverage may be purchased. The extended warranty term may be purchased until eighteen (18) months after the product is shipped, after which time no extended warranties are available.

Any extension of the Limited Warranty under this program must be in writing, signed by DRI-STEEM, and paid for in full by the purchaser.

mc\_051308\_0630