

**DRISTEEM**<sup>®</sup>  
The humidification experts



Ultra-sorb Model LV



Ultra-sorb Model LH



Ultra-sorb Model XV

**Ultra-sorb**<sup>®</sup>  
Steam Dispersion Panels

PRODUCT CATALOG



## Short absorption for any application

*DRI-STEEM takes the lead again with Ultra-sorb, establishing the industry standard for energy and water conservation in commercial and industrial humidification.*

DRI-STEEM's Dri-calc<sup>®</sup> software is available to calculate your application-specific non-wetting distances.

Visit the Dri-calc page at [www.dristeem.com](http://www.dristeem.com) (or [click here](#)) to request a free copy of Dri-calc.

### Guaranteed non-wetting distances

DRI-STEEM made impossible applications feasible in 1991 with the introduction of Ultra-sorb<sup>®</sup> steam dispersion panels. With Ultra-sorb, DRI-STEEM was first to provide cataloged, guaranteed absorption (non-wetting) distances for placement of steam dispersion devices without condensate fallout or impingement. Steam dispersion parameters that had required a 48 inch (1220 mm) non-wetting distance could be achieved in 18 inches (460 mm) with Ultra-sorb, and Ultra-sorb remains the industry standard for short absorption.

Guaranteed non-wetting distances allow Ultra-sorb panels to be installed within inches of downstream devices without condensation. Non-wetting distance charts allow you to choose equipment that will accommodate your application. See Figure 19-1.

### Reduce wasted energy with high-efficiency tubes

DRI-STEEM took the industry-leading performance of Ultra-sorb one step further with its high-efficiency tubes. Revolutionary high-efficiency tubes reduce wasted energy by up to 85% by significantly reducing airstream heat gain and condensate production. See *High-efficiency tubes* on Page 7.

### Return pressurized condensate without additional mechanical means

An industry first for pressurized steam, Ultra-sorb now vaporizes dispersion-generated condensate and returns pressurized condensate to the boiler without additional pumps, valves, or controls.

DRI-STEEM combines the following benefits in one dispersion panel:

- Short absorption established by Ultra-sorb
- Energy savings of high-efficiency tubes and header
- Integral heat exchanger for pressurized condensate return

The performance of Ultra-sorb, now with condensate management and breakthrough efficiency.

## Expanded Ultra-sorb family

With Ultra-sorb, DRI-STEEM introduces the most energy-efficient steam dispersion panels in the market today. Ultra-sorb panels employ proven technologies to deliver short absorption and high efficiency and are available in an expanded product selection.

### Ultra-sorb Model XV

- Shortest absorption
- Most efficient:
  - High-efficiency tubes
  - Insulated header
- Vaporizes generated condensate
- Returns pressurized condensate
- Easy installation
- For pressurized steam applications, 5 psi (35 kPa) minimum
- Steam capacity up to 1610 lbs/hr (730 kg/hr)

### Ultra-sorb Model LV and Ultra-sorb Model LH

- Shortest absorption
- Optional high-efficiency tubes
- Easy installation
- For pressurized or evaporative steam applications
- Steam capacity up to 4000 lbs/hr (1815 kg/h)

**Figure 3-1:**  
**Ultra-sorb Model XV**



**Figure 3-2:**  
**Ultra-sorb Models LV and LH**

### Ultra-sorb Model LV

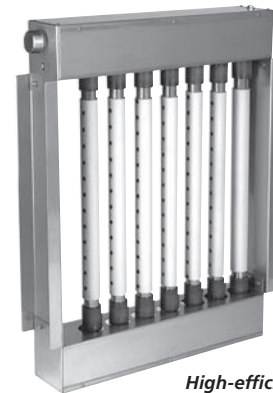

*High-efficiency Tube  
option shown*

### Ultra-sorb Model LH



## Ultra-sorb Model XV

**Figure 4-1:**  
**Ultra-sorb Model XV**



**Figure 4-2:**  
**Ultra-sorb Model XV simultaneously vaporizes generated condensate and returns pressurized condensate**

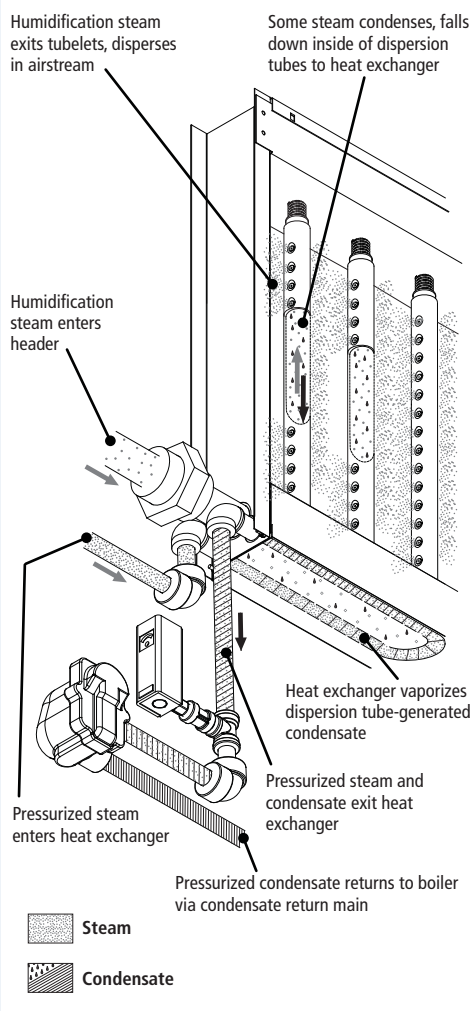

- **Install within inches of downstream devices:** Rapid, drip-free steam absorption means steam does not condense on downstream devices. DRI-STEEM guarantees that properly specified and installed Ultra-sorb panels will not cause dripping or standing water in ductwork or air handlers.
- **High-efficiency system:** High-efficiency dispersion tubes are insulated with polyvinylidene fluoride (PVDF). The insulation provides up to an 85% reduction in wasted energy by significantly reducing airstream heat gain and condensate production (see Page 7). The cool outside surfaces of the insulated tubes and header make Ultra-sorb Model XV the lowest in airstream heat gain.
- **Condensate vaporizing:** All dispersion tube-generated condensate falls to the heat exchanger in the header, where it is vaporized into humidification steam (see Figure 4-2).
- **Pressurized condensate return:** As condensate is vaporized in the header, pressurized condensate is returned to the condensate return main without additional pumps, valves, or controls (see Figure 4-2).
- **Zero water waste:** All condensate can easily be returned to the boiler while still hot, saving not only water, but also energy and boiler chemicals.
- **Factory assembly eases installation:** Panels are shipped preassembled, similar to a steam coil, and placed in air handlers and ductwork with easy mounting and steam and condensate connections. Panels with overall height more than 98" (2490 mm) are shipped unassembled. Units may also be shipped unassembled by request.
- **Steam exits drip-free through tubelets:** Thermal-resin tubelets extend into dispersion tube center and capture only the driest, hottest steam (see Figure 5-2). These insulated orifices allow hot steam to cross over cool metal without condensing. Tubelet orifices are calibrated for duct air velocity and steam capacity.
- **No steam jackets; no unnecessary heat gain:** Ultra-sorb's slim-profile, unjacketed dispersion tubes provide more airflow across the panel for better steam absorption. When there is no call for humidity, Ultra-sorb panels are at duct temperature, while conventional jacketed steam injection systems stay hot and continue to add heat to the airstream.
- **Numerous steam discharge points improve absorption:** The more steam discharge points over the airstream cross section, the more thorough the mixing. Slim tube profiles allow for more tubes and more steam discharge points. Ultra-sorb panels are designed with the maximum number of dispersion tubes that does not restrict airflow.

## Ultra-sorb Models LV and LH

- **Install within inches of downstream devices:** Rapid, drip-free steam absorption means steam does not condense on downstream devices. DRI-STEEM guarantees that properly specified and installed Ultra-sorb panels will not cause dripping or standing water in ductwork or air handlers.
- **High-efficiency Tube option:** High-efficiency dispersion tubes are insulated with PVDF. The insulation provides up to an 85% reduction in wasted energy by significantly reducing airstream heat gain and condensate production.  
High-efficiency tubes are an option for new or installed Models LV and LH (see Page 7).
- **Factory assembly eases installation:** Panels are shipped preassembled, similar to a steam coil, and placed in air handlers and ductwork with easy mounting and steam and condensate connections. Panels with overall height more than 98" (2490 mm) are shipped unassembled. Units may also be shipped unassembled by request.
- **Works with any steam pressure:** Models LV and LH disperse steam generated by pressurized steam boilers or by evaporative (nonpressurized) humidifiers such as DRI-STEEM's GTS®, LTS®, STS®, Vaporstream®, Vapormist®, and VT and XT Series humidifiers.
- **Steam exits drip-free through tubelets:** Thermal-resin tubelets extend into dispersion tube center and capture only the driest, hottest steam. These insulated orifices allow hot steam to cross over cool metal without condensing. Tubelet orifices are calibrated for duct air velocity and steam capacity. See Figure 5-2.
- **No steam jackets; no unnecessary heat gain:** Ultra-sorb's slim-profile, unjacketed dispersion tubes allow more airflow across the panel for better steam absorption. When there is no call for humidity, Ultra-sorb panels are at duct temperature, while conventional jacketed steam injection systems stay hot and continue to add heat to the airstream.
- **Numerous steam discharge points improve absorption:** The more steam discharge points over the airstream cross section, the more thorough the mixing. Slim tube profiles allow for more tubes and more steam discharge points. Ultra-sorb panels are designed with the maximum number of dispersion tubes that does not restrict airflow.

**Figure 5-1:**  
**Ultra-sorb Models LV & LH**



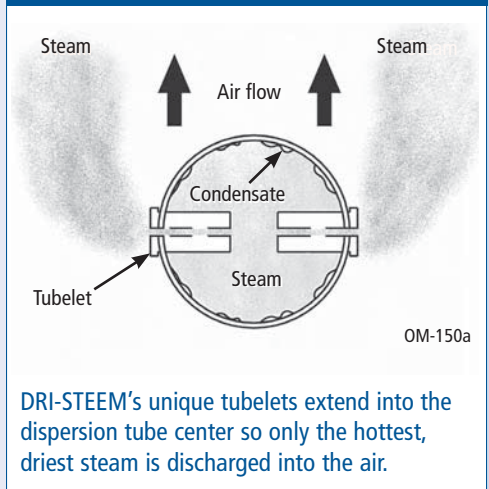

**Figure 5-2:**  
**Tubelets**



## Model comparison

**Table 6-1:  
Ultra-sorb steam dispersion panels comparison chart**

Specification	Ultra-sorb Model XV (integral heat exchanger) 	Ultra-sorb Model LV (vertical tubes) 	Ultra-sorb Model LH (horizontal tubes) 
<b>Steam source / application</b>	Pressurized boiler steam, horizontal airflow	Pressurized boiler or evaporative steam, horizontal airflow	Pressurized boiler steam in vertical or horizontal airflow; evaporative steam in a vertical airflow
<b>Steam capacity</b>	Up to 1610 lbs/hr (730 kg/h)	Up to 4000 lbs/hr (1815 kg/h)	
<b>Steam pressure</b>	5 to 50 psi (35 to 345 kPa)	Evaporative up to 50 psi (up to 345 kPa)	
<b>High-efficiency dispersion tubes</b>	Standard	Available option	
<b>Header insulation</b>	Header inside of enclosure is insulated	Not available	
<b>Condensate drain</b>	Pressurized	Atmospheric	
<b>Condensate lifting</b>	Vaporizes dispersion tube-generated condensate in header; returns pressurized condensate to condensate return main	Available pump	
<b>Airstream heat gain</b>	Lowest	Low with High-efficiency Tube option	
<b>Non-wetting distance</b>	Shortest; performs to published Ultra-sorb non-wetting distance		
<b>Panel size</b>	12" x 12" up to 144" x 144" (305 x 305 mm to 3660 x 3660 mm)	12" x 12" up to 144" x 144" (305 x 305 mm to 3660 x 3660 mm)	12" x 12" up to 120" x 120" (305 x 305 mm to 3050 x 3050 mm)
<b>Assembly</b>	Pre-assembled (shipped unassembled by request or as larger dimensions require)		
<b>Dispersion tube mounting</b>	Spring-loaded tubes and frame	Slip couplings and frame	
<b>Steam / drain connections</b>	1 inlet: steam for humidification 1 inlet: pressurized steam for heat exchanger 1 outlet: pressurized, to condensate return main 1 outlet: for optional header overflow	1 inlet: steam for humidification 1 outlet: condensate drain	
<b>Airflow</b>	Horizontal	Horizontal	Horizontal or vertical
<b>Weight</b>	For Ultra-sorb weights, see our free Dri-calc sizing and selection software. Visit the <a href="http://www.dristeem.com">Dri-calc page</a> at www.dristeem.com to order a free copy of Dri-calc.		
<b>Piping connections</b>	Same-side connections	Top or side steam inlet, opposite-side drain connection	Top or side steam inlet, 2 drain connections (one per header)

## High-efficiency tubes

The PVDF insulation on high-efficiency dispersion tubes allows up to an 85% reduction in wasted energy by significantly reducing airstream heat gain and condensate production. The energy savings can yield payback in less than one year.

DRI-STEEM co-developed PVDF insulation for humidification applications when no available material could provide significant insulating results, withstand the environmental challenges of steam humidification, and meet strict plenum requirements.

High-efficiency tubes are standard on Ultra-sorb Model XV and an available option for new or existing Ultra-sorb Models LV and LH. See *Retrofit option* on Page 30.

### Advanced insulation meets stringent requirements

PVDF is an advanced material commonly used in chemical, semiconductor, medical, defense, and aerospace industries and has the following characteristics:

- **Approved for use in plenums:** Flame spread/smoke developed values are 0/0, exceeding UL 723 (ASTM E84) requirement of 25/50.
- **Rated for high-temperature operation:** Rated for 300 °F (149 °C) continuous operation.
- **Closed-cell structure will not absorb water or support microbial growth.**
- **Will not shift or slip on tubes:** Advanced manufacturing process ensures insulation attaches securely to tubes.
- **Odor free:** virtually no measurable outgassing.
- **Resistant to UV light.**
- **Rugged and durable:** No particle erosion per ASTM C1071 erosion resistance test; does not contain fiberglass.

### See our white paper

For complete details on the breakthrough performance of high-efficiency tubes, see our *High-efficiency Tube option* white paper on the **Education & Resources** page at [www.dristeem.com](http://www.dristeem.com) (or [click here](#)).

**Figure 7-1:**  
Dispersion tube heat loss vs. airspeed at 50 °F (10 °C) for a 3" (76 mm) o.c. tube bank, 1½" (DN40) dia. stainless steel tubes with 212 °F (100 °C) internal wall temperature

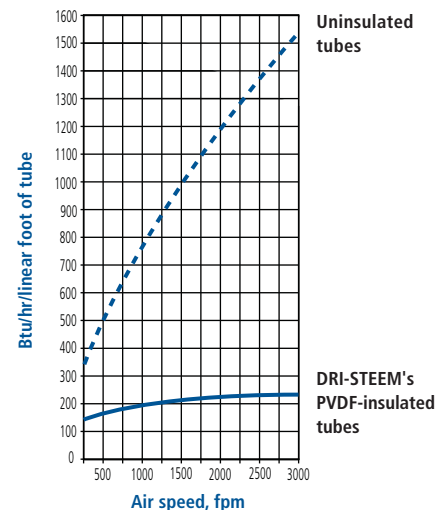

**Notes:**

- Heat loss calculations based on the following references: Zhukauskas, A. 1987. *Convective Heat Transfer in Cross Flow*. In S. Kakac, R.K. Shah, and W. Ang, eds. *Handbook of Single-Phase Convective Heat Transfer*. New York: John Wiley & Sons, pp. 6.1-6.45.
- PVDF insulation on tube is 1/8" (3.2 mm) thick and has a thermal conductivity of 0.0185 Btu/hr-ft-F 0.0107 W/m•K.

### The performance you expect from DRI-STEEM

- High-efficiency tubes reduce airstream heat gain and condensate production by up to 85% compared to uninsulated tubes, regardless of load or airstream temperature.
- Condensate reduction correlates directly to energy savings. Every pound of condensate that does not drain from the dispersion assembly saves on the Btus (about 1,000) required to boil it into steam.
- Condensate reduction allows smaller steam generators. With a higher percentage of generated steam meeting the humidification load, steam generators can be downsized in many cases.
- The added PVDF insulation causes no excessive airflow pressure drop; provides exceptionally high performance at 1/8" (3.2 mm) thick.

## Ultra-sorb Model XV components

### Ultra-sorb Model XV vaporizes condensate, returns pressurized condensate

Vaporizing dispersion-generated condensate while returning pressurized condensate to the boiler provides significant savings:

- One Btu of energy is required to heat 1 pound of water 1 °F; therefore, it takes 157 Btus to bring 1 pound of 55 °F water to a boiling temperature:  
 $212\text{ °F} - 55\text{ °F} = 157\text{ °F} = 157\text{ Btus}$
- A 120" x 120" Ultra-sorb with high-efficiency tubes on 3" centers produces 74 lbs/hr of condensate\*; therefore, running nonstop all year (8,760 hours), it would produce 648,240 lbs/year:  
 $74\text{ lbs/hr} \times 8,760\text{ hr/yr} = 648,240\text{ lbs/yr}$   
\* A comparable panel with uninsulated tubes produces 299 lbs/hr of condensate.
- An Ultra-sorb Model XV returning this condensate to the boiler, instead of wasting it to a drain, would recycle 101,773,680 Btus per year:  
 $(1\text{ Btu/lb/°F} \times 648,240\text{ lbs/yr}) \times (212\text{ °F} - 55\text{ °F}) = 101,773,680\text{ Btus/yr}$
- Assuming 85% boiler efficiency and the 101.8 million Btus saved in the equation above, the actual annual energy savings is almost 120 million Btus:  
 $101,773,680\text{ Btu} / 0.85 = 119,733,741\text{ Btus}$

Plus, replenishing the boiler with the very steam that left the boiler saves on chemicals. For every gallon of pressurized condensate returned to the boiler, that's one less gallon of fresh, make-up water requiring boiler chemicals.

For metric units, see the [Product literature: Ultra-sorb](#) section of our web site: [www.dristeem.com](http://www.dristeem.com)

### Heat exchanger on-off valve (1)

Upon a call for humidification, the heat exchanger on-off valve opens, and pressurized steam flows through the heat exchanger and out the trap (A). The modulating steam valve (3) is off.

### Heat exchanger temperature switch sensor (2)

When the heat exchanger temperature switch sensor reaches operating temperature, it closes to allow the modulating steam valve (3) to open and modulate steam according to the humidification control system's call for humidity. During normal operation, the temperature remains above operating temperature, the temperature switch remains closed, and the modulating steam valve is controlled by the humidification control system.

This circuit's sequence of operation is a safety sequence: In the unlikely event that excessive header condensate cools the heat exchanger while humidifying, the temperature sensor drops below operating temperature and opens, which disables the modulating steam valve and prevents further condensate production. After the header condensate evaporates, the sensor switch closes, which enables the modulating steam valve and allows humidification steam to flow when there is a call for humidity.

### Modulating steam valve (3)

Humidification steam passes through the modulating steam valve and through the steam supply inlet (B) into the header.

### Header (4)

Steam flows through the insulated header and up the high-efficiency dispersion tubes.

### High-efficiency dispersion tubes (5)

Calibrated thermal-resin tubelets (5a) allow only the driest steam to exit into the airstream. Dispersion tube insulation (5b) provides up to an 85% reduction in wasted energy by significantly reducing airstream heat gain and condensate production (see page 7).

Dispersion tube spring-ends (5c) provide rapid tube removal and installation while ensuring tight seals (5d) between the header and tubes.

# Ultra-sorb Model XV components

## Heat exchanger (6)

Pressurized steam enters the heat exchanger inlet (6a). Its heat vaporizes (flashes) condensate falling out of the dispersion tubes. Simultaneously, the volume of condensate vaporized in the header causes an equal volume of pressurized condensate, which is returned (6b) to the boiler via the condensate return main. The access port (6c) can be used for an optional header overflow P-trap water seal.

## Time-delay relay (not shown)

Upon a drop in the call for humidification, the time-delay relay keeps the heat exchanger valve open for 30 minutes (or as field set), allowing steam to flow through the heat exchanger and dry out the header. This prevents microbial growth during prolonged non-humidifying periods.

**Figure 9-1:**  
**Ultra-sorb Model XV components**

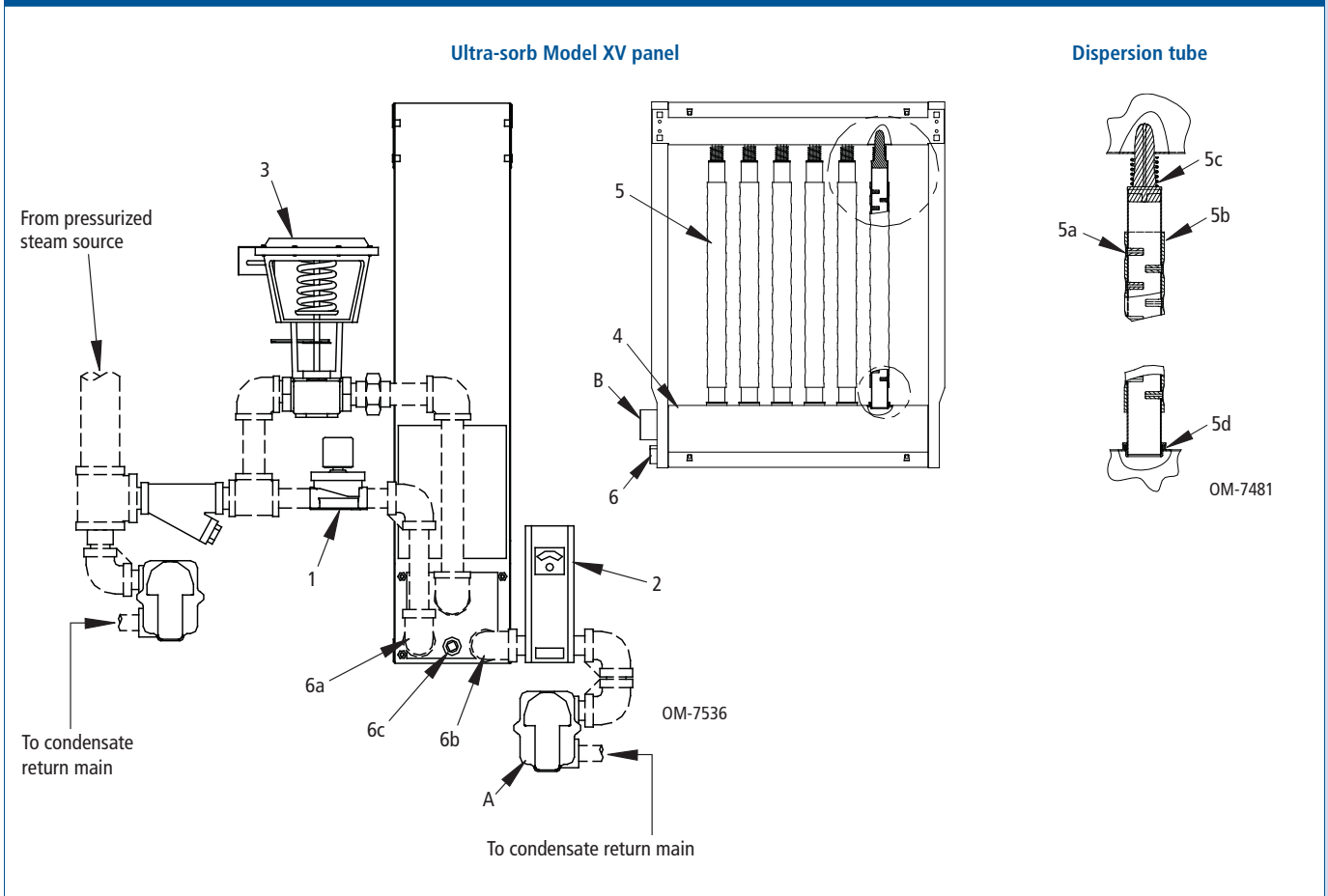

## Ultra-sorb Model XV connections

### Ultra-sorb Model XV

- High-efficiency dispersion tubes
- Insulated header
- Pre-assembled for easy installation
- Dispersion tube spring-ends allow rapid tube removal for easy service
- Heat exchanger in header evaporates generated condensate
- Returns pressurized condensate
- Suitable for AHUs or ductwork
- For horizontal airflows
- For pressurized steam applications, 5 psi (35 kPa) minimum

**Figure 10-1:**  
**Ultra-sorb Model XV connections**

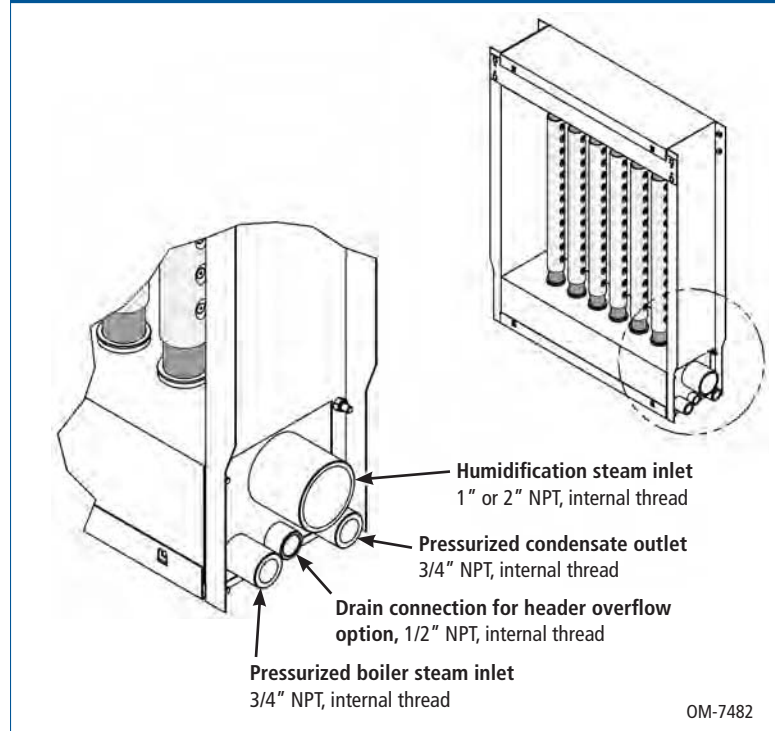

# Ultra-sorb Model XV dimensions

**Figure 11-1:**  
Ultra-sorb Model XV dimensions

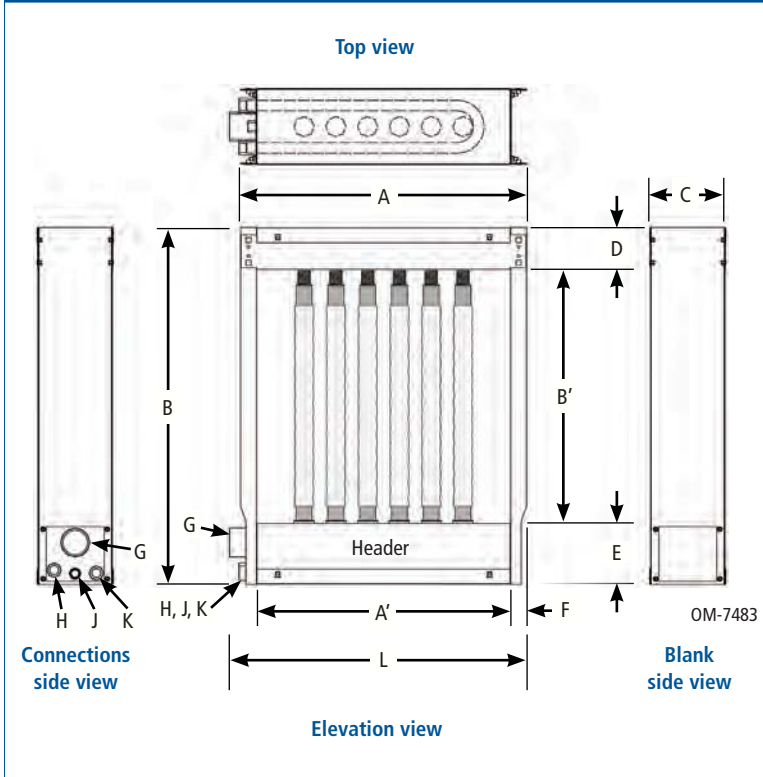

**Table 11-1:**  
Ultra-sorb Model XV dimensions

Dimension	Inches (mm)
A Panel width	15" (380) min, 147" (3735) max, in 1" (25) increments
A' Face width	12" (305) min, 144" (3660) max, in 1" (25) increments
B Overall height*	21.75" (550) min, 153.75" (3905) max, in 1" (25) increments
B' Face height	12" (305) min, 144" (3660) max, in 1" (25) increments
C Frame depth	7.2" (183)
D Frame enclosure	3.9" (99)
E Header enclosure	5.85" (149)
F Mounting flange	1.5" (38)
G Humidification steam inlet (internal thread)	1" or 2" NPT, determined by maximum steam capacity
H Pressurized steam inlet (internal thread)	3/4" NPT
J Access port and optional overflow (internal thread)	1/2" NPT
K Pressurized condensate outlet (internal thread)	3/4" NPT
L Overall width	1" connection, same as dimension A; 2" connection, dimension A + 1"
Control cabinet	See Figure 21-2 on Page 21.

\* Panels with overall height more than 120" (3048 mm) have two-piece side flanges and are shipped with brackets and panel fasteners for easy field assembly. Panels with overall height more than 98" (2490 mm) are shipped unassembled.

mc\_091608\_1500

## Ultra-sorb Models LV and LH components

### Ultra-sorb Models LV and LH: Steam source versatility, robust design

- Ultra-sorb Models LV and LH function at any steam pressure — from pressurized steam down to mere ounces — to disperse boiler steam as well as evaporative humidifier steam.
- Unique, patented, double-header design allows steam to enter one header while condensate exits the other header.
- The dispersion tubes operate drip-free without steam jackets, so no unnecessary heat is added to the airstream when the humidifier is idle, even with non-insulated tubes.

#### 1. Steam supply inlet

Steam enters the supply header from a boiler (after passing through a steam control valve) or an evaporative humidifier.

#### 2. Steam supply header/separator

Dispersion tube diagonal end cuts capture only the driest steam from the center of the header. Condensate falls to the condensate return header.

#### 3. Dispersion tubes

Steam flows through the dispersion tubes and into the airstream through tubelets.

#### 4. Tubelets

Calibrated thermal-resin tubelets allow only the driest steam to exit into airstream.

#### 5. Condensate return header

Condensate flows by gravity into the condensate return header.

#### 6. Condensate drain

Condensate leaves the condensate return header through the condensate drain.

#### 7. Dispersion tube insulation (optional, see Page 7)

Dispersion tube insulation provides up to an 85% reduction in wasted energy by significantly reducing airstream heat gain and condensate production.

Figure 12-1:  
Ultra-sorb Models LV and LH components

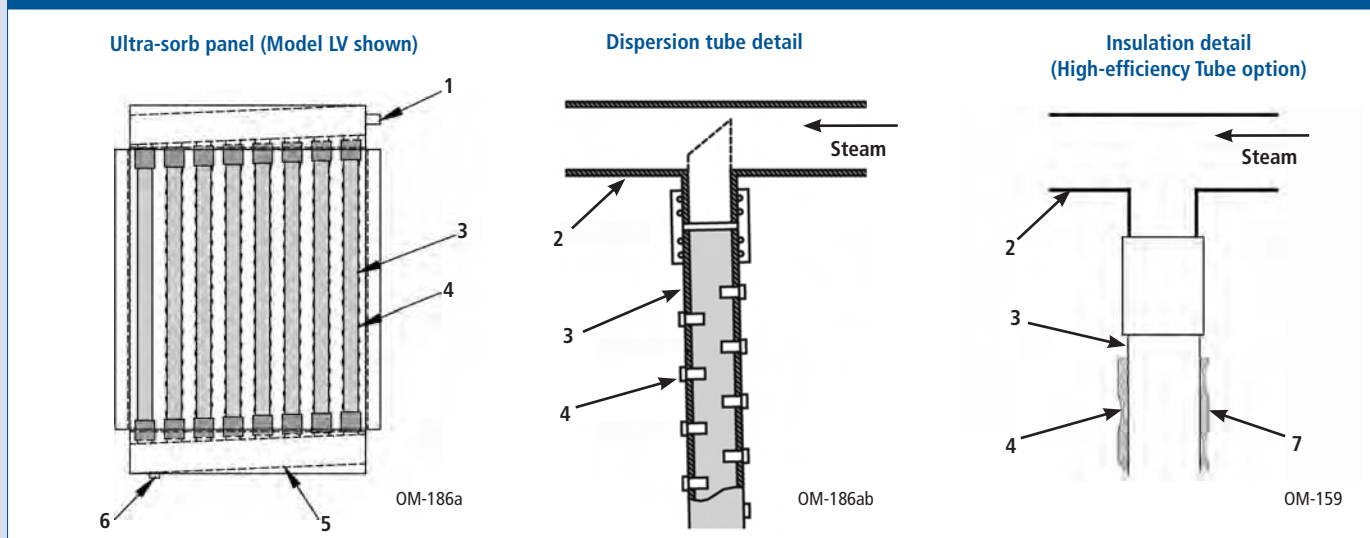

# Ultra-sorb Models LV and LH connections

**Figure 13-1:**  
Ultra-sorb Models LV and LH steam inlet types

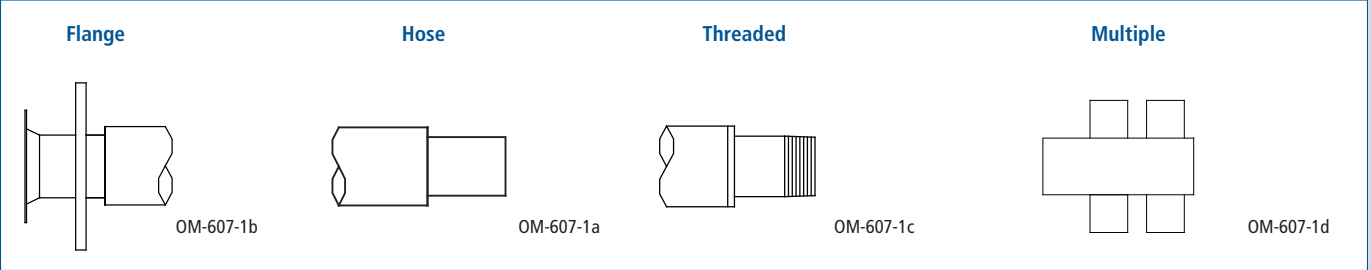

**Figure 13-2:**  
Ultra-sorb Models LV and LH steam inlet and condensate outlet positions

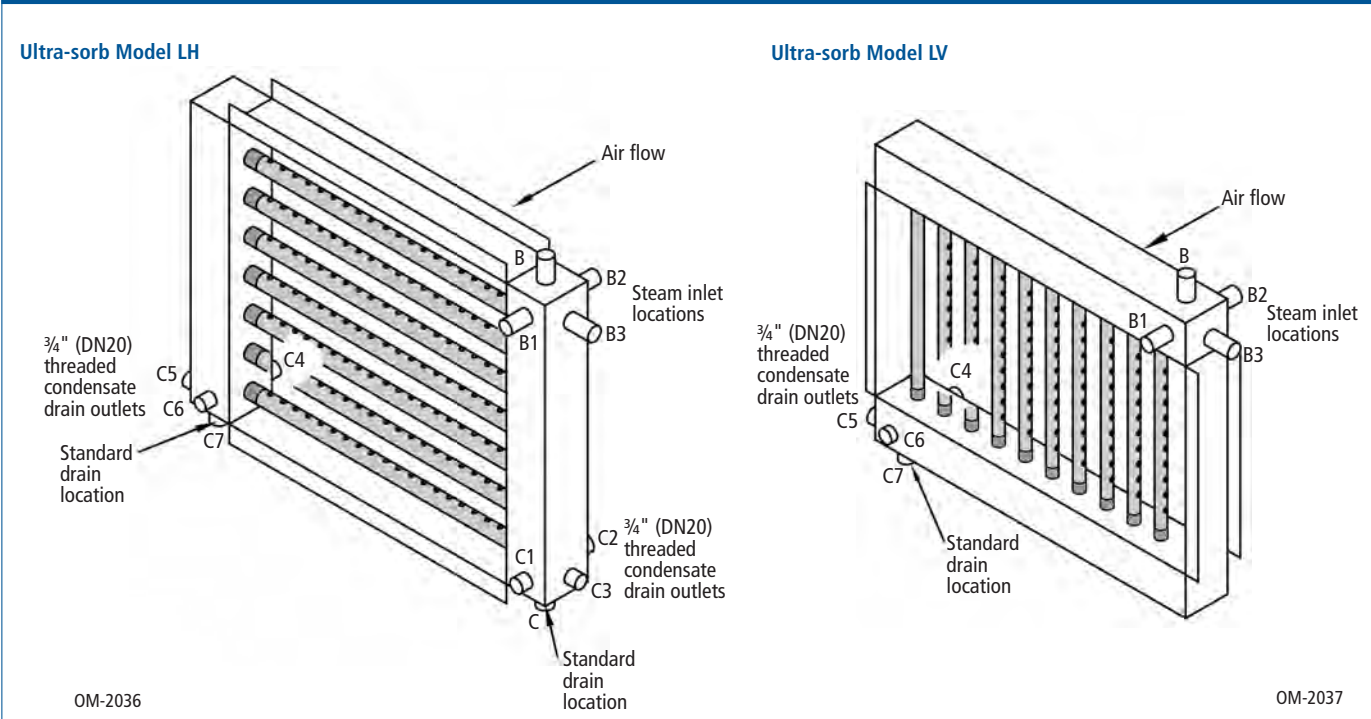

**Table 13-1:**  
Standard length steam inlet extends beyond header

Inlet type	Inlet nominal diameter, inches (DN)										
	1/2" (15)	3/4" (20)	1" (25)	1 1/4" (32)	1 1/2" (40)	2" (50)	3" (80)	4" (100)	5" (125)	6" (150)	
Nipple	2.83" (72 mm)					2.95" (75 mm)	3.95" (93 mm)	—			
Hose	—				2.83" (72 mm)		3.95" (93 mm)		—		
Flange	—						3.95" (93 mm)			5.95" (151 mm)	

# Ultra-sorb Model LV dimensions

## Ultra-sorb Model LV

- Vertical dispersion tubes
- Suitable for AHUs or ductwork
- Use when duct height is greater than duct width
- May use with pressurized or evaporative steam (horizontal airflow only)

**Table 14-1:  
Evaporative steam header capacities**

Header capacity		Header diameter	
lbs/hr	kg/h	inches	DN
300	135	3	80
600	270	4	100
1100	500	5	125
1850	820	6	150

**Figure 14-1:  
Ultra-sorb Model LV dimensions**

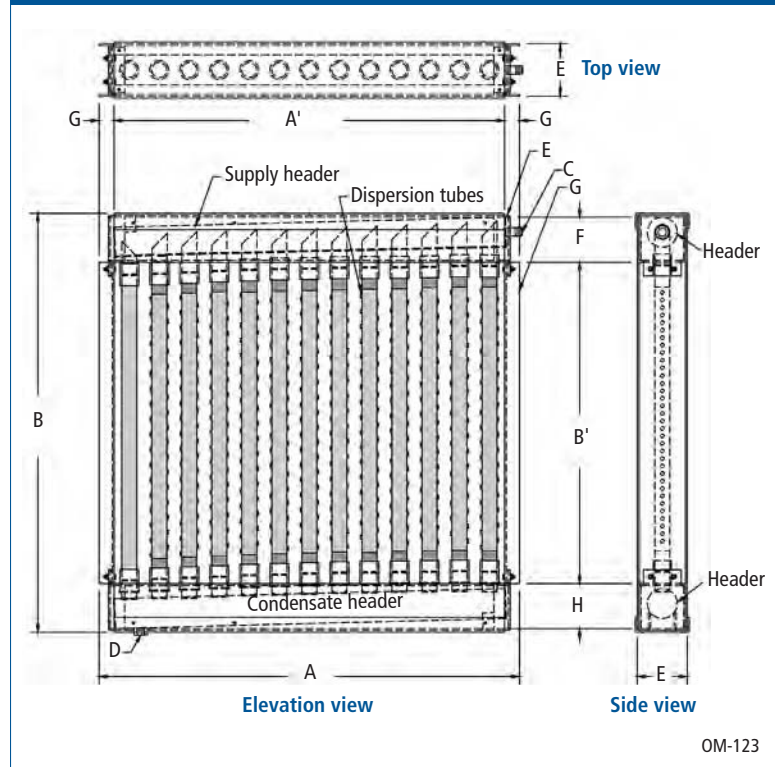

**Table 14-2:  
Ultra-sorb Model LV dimensions**

Dimension	Inches (mm)
A Overall width	15" (380) min, 147" (3735) max, in 1" (25) increments
A' Face width	12" (305) min, 144" (3660) max, in 1" (25) increments
B Overall height	21" (530) min, 156" (3960) max, in 1" (25) increments Shipped unassembled by request or if overall height is more than 98" (2490 mm).
B Face height	12" (305) min, 144" (3660) max, in 1" (25) increments
C Steam inlet diameter	Determined by maximum steam capacity
D Condensate drain	¾" pipe thread (DN20)
E Header enclosure (front to back)	For 3" (DN80) and 4" (DN100) headers, E = 5" (127); for 5" (DN125) header, E = 6" (152); for 6" (DN150) header, E = 7" (178)
F Header enclosure (top to bottom)	For 3" (DN80) header F = 4.5" (114); for 4" (DN100) header, F = 5.5" (140); for 5" (DN125) header, F = 6.5" (165); for 6" (DN150) header F = 7.5" (191)
G Mounting flange	1.5" (38)
H Condensate header enclosure	4.5" (114)

**Note:** Header dimensions are determined by capacity. See Tables 14-1 and 15-1.

mc\_050808\_1215

# Ultra-sorb Model LH dimensions

**Figure 15-1:  
Ultra-sorb Model LH dimensions**

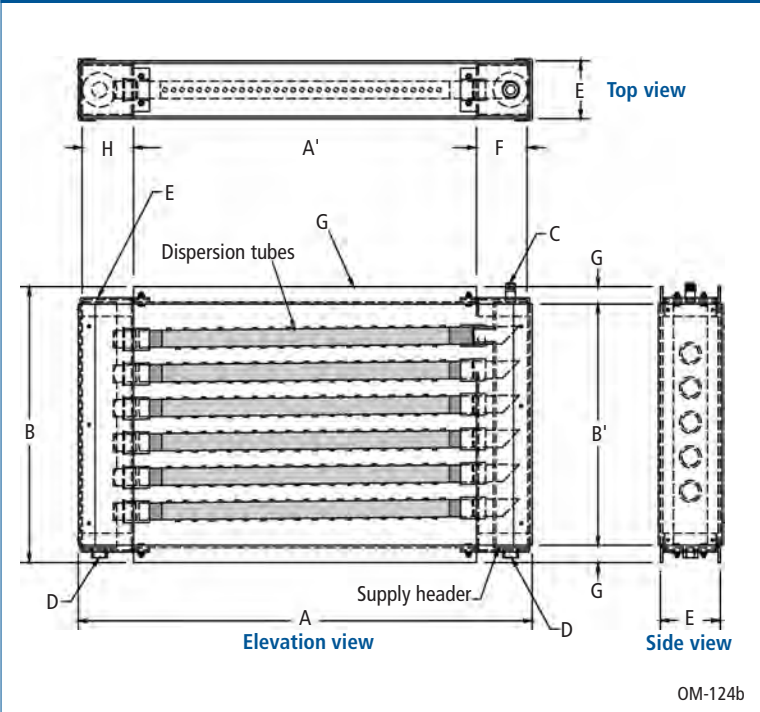

## Ultra-sorb Model LH

- Horizontal dispersion tubes
- Suitable for AHUs or ductwork
- Use when duct width is greater than duct height
- May use with pressurized steam in a vertical or horizontal airflow; may use with evaporative steam only in a vertical airflow

**Table 15-1:  
Boiler steam header capacities**

Header capacity		Header diameter	
lbs/hr	kg/h	inches	DN
980	445	3	80
1750	793	4	100
2750	1245	5	125
4000	1815	6	150

**Table 15-2:  
Ultra-sorb Model LH dimensions**

Dimension	Inches (mm)
<b>A</b> Overall width	21" (530) min, 129" (3280) max, in 1" (25.4) increments
<b>A'</b> Face width	12" (305) min, 120" (3050) max, in 1" (25.4) increments
<b>B</b> Overall height	15" (380) min, 120" (3050) max, in 1" (25.4) increments Shipped unassembled by request or if overall height is more than 98" (2490 mm).
<b>B'</b> Face height	12" (305) min, 120" (3050) max, in 1" (25.4) increments
<b>C</b> Steam inlet diameter	Determined by maximum steam capacity
<b>D</b> Condensate drain	3/4" pipe thread (DN20)
<b>E</b> Header enclosure (front to back)	For 3" (DN80) and 4" (DN100) headers, E = 5" (127); for 5" (DN125) header, E = 6" (152); for 6" (DN150) header, E = 7" (178)
<b>F</b> Header enclosure (top to bottom)	For 3" (DN80) header F = 4.5" (114); for 4" (DN100) header, F = 5.5" (140); for 5" (DN125) header, F = 6.5" (165); for 6" (DN150) header F = 7.5" (191)
<b>G</b> Mounting flange	1.5" (38)
<b>H</b> Condensate header enclosure	4.5" (114)

**Note:** Header dimensions are determined by capacity. See Tables 14-1 and 15-1.

## Selecting an Ultra-sorb

### Note:

For Ultra-sorb selection and absorption calculations with metric units, see the metric version of this catalog in the [Product literature: Ultra-sorb](#) section of our web site: [www.dristeem.com](http://www.dristeem.com)

When selecting an Ultra-sorb model, choose a panel with face dimensions (dispersion tubes) that closely approximate the upstream heating or cooling coil dimensions. Models LV and LH panel sizes must allow for adequate clearance to accommodate the condensate drain piping.

### Example

Select an Ultra-sorb panel for a 100% makeup air unit with a cooling coil bank 84" wide and 36" high, given the following conditions:

- Air volume = 10,000 cfm
- Design entering conditions = 10 °F and 60% RH
- The air will be conditioned to 55 °F and humidified to 90% RH. The entrance to the blower is 42" downstream from the Ultra-sorb, which means the non-wetting distance must be 42" or less.

### Step 1: Determine the load

- Refer to Table 17-1.
- 55 °F and 90% RH = 3.76 lbs/hr/100 cfm
- 10 °F and 60% RH = 0.40 lbs/hr/100 cfm
- Subtracting 0.40 from 3.76 leaves 3.36 lbs/hr/100 cfm to be added
- $(10,000 \times 3.36)/100 = 336$  lbs/hr load

### Step 2: Determine the RH of the air entering the Ultra-sorb

This step determines the "RH/temperature rise" which affects non-wetting distance. First convert the entering RH (60%) at 10 °F to its RH equivalent at the leaving temperature (55 °F). From Table 17-1, note that the amount of moisture in 60% RH at 10 °F (0.40) is about the same as 10% at 55 °F (0.42).

*Continued* ►

### Capacity loss

Ultra-sorb Models LV and LH steam dispersion panels condense some of their humidification steam. This could result in an undersized humidifier being specified if the effect on load is not properly addressed. A general rule of thumb when using an Ultra-sorb panel with 3-inch (75 mm) tube spacing and uninsulated tubes is to increase the calculated load by 10% to 15% to compensate for this loss.

Ultra-sorb panels with the High-efficiency Tube option have insulated tubes and condense less of the steam. When using high-efficiency tubes, increase the calculated load by only 4% to 8%, depending on tube spacing, air speed, and other factors.

Use DRI-STEEM's Dri-calc sizing and selection software to calculate actual losses with your specific parameters.

## Selecting an Ultra-sorb

**Table 17-1:  
Pounds of moisture per hour per 100 cfm at sea level**

Air temp. °F	Percentage of saturation																
	5%	10%	15%	20%	25%	30%	35%	40%	45%	50%	55%	60%	65%	70%	80%	90%	100%
-20	0.00	0.014	0.022	0.03	0.035	0.043	0.05	0.057	0.064	0.071	0.078	0.085	0.093	0.099	0.114	0.13	0.14
-10	0.012	0.025	0.037	0.05	0.06	0.074	0.085	0.097	0.11	0.121	0.134	0.147	0.159	0.171	0.20	0.22	0.24
0	0.02	0.04	0.06	0.081	0.102	0.121	0.142	0.162	0.184	0.204	0.223	0.245	0.265	0.285	0.33	0.36	0.40
10	0.033	0.066	0.10	0.133	0.166	0.20	0.232	0.266	0.30	0.332	0.364	0.40	0.434	0.465	0.54	0.59	0.66
20	0.053	0.107	0.16	0.215	0.262	0.32	0.374	0.430	0.494	0.535	0.583	0.635	0.695	0.758	0.86	0.96	1.05
30	0.085	0.17	0.25	0.33	0.42	0.50	0.585	0.67	0.75	0.84	0.92	1.00	1.09	1.17	1.34	1.49	1.65
40	0.12	0.24	0.37	0.48	0.60	0.74	0.84	0.96	1.08	1.20	1.31	1.45	1.53	1.68	1.98	2.20	2.43
50	0.17	0.35	0.52	0.70	0.88	1.05	1.24	1.40	1.58	1.76	1.93	2.12	2.30	2.46	2.83	3.16	3.49
55	0.21	0.42	0.63	0.84	1.05	1.26	1.47	1.68	1.90	2.10	2.30	2.53	2.74	2.94	3.37	3.76	4.16
60	0.22	0.44	0.75	0.89	1.25	1.49	1.74	1.98	2.24	2.50	2.72	2.99	3.24	3.48	4.00	4.46	4.93
65	0.29	0.58	0.86	1.16	1.36	1.75	2.04	2.32	2.63	2.92	3.20	3.50	3.80	4.06	4.73	5.27	5.82
68	0.32	0.65	0.98	1.30	1.63	1.96	2.28	2.60	2.84	3.26	3.56	3.91	4.24	4.55	5.23	5.84	6.05
69	0.33	0.67	1.00	1.33	1.68	2.00	2.35	2.66	3.01	3.35	3.66	4.03	4.36	4.68	5.40	6.04	6.38
70	0.34	0.68	1.02	1.37	1.72	2.05	2.40	2.74	3.10	3.44	3.75	4.12	4.46	4.80	5.56	6.20	6.45
71	0.36	0.72	1.07	1.43	1.78	2.15	2.50	2.85	3.21	3.55	3.90	4.29	4.65	5.00	5.74	6.40	7.07
72	0.37	0.74	1.10	1.47	1.84	2.20	2.58	2.94	3.32	3.68	4.03	4.44	4.80	5.15	5.91	6.60	7.29
73	0.38	0.76	1.14	1.51	1.90	2.28	2.66	3.03	3.43	3.80	4.16	4.57	4.95	5.31	6.12	6.83	7.54
74	0.39	0.78	1.19	1.56	1.97	2.37	2.75	3.13	3.54	3.93	4.31	4.74	5.14	5.51	6.32	7.05	7.78
75	0.40	0.81	1.21	1.62	2.03	2.42	2.84	3.23	3.65	4.06	4.45	4.86	5.28	5.65	6.55	7.27	8.03
77	0.42	0.85	1.29	1.73	2.16	2.58	3.02	3.42	3.82	4.33	4.73	5.13	5.63	6.04	6.94	7.75	8.55
80	0.47	0.94	1.42	1.90	2.37	2.84	3.30	3.75	4.20	4.75	5.19	5.63	6.18	6.62	7.62	8.50	9.38
85	0.54	1.09	1.66	2.19	2.78	3.32	3.88	4.39	4.91	5.56	6.07	6.59	7.23	7.75	8.92	9.95	10.98
90	0.62	1.25	1.87	2.47	3.12	3.74	4.37	4.95	5.53	6.25	6.84	7.43	8.15	8.73	10.03	11.20	12.37

## Determining absorption

**Table 18-1:  
Ultra-sorb air pressure loss**

Duct air velocity (55 °F [13 °C] at sea level)		Tube spacing				
		3"	75 mm	6"	150 mm	
Uninsulated tubes	fpm	m/s	wc	Pa	wc	Pa
	500	2.54	0.020	5.1	0.004	1.1
	1000	5.08	0.082	20.5	0.017	4.2
	1500	7.62	0.175	43.8	0.038	9.5
High-efficiency tubes	fpm	m/s	wc	Pa	wc	Pa
	500	2.54	0.033	8.3	0.005	1.3
	1000	5.08	0.121	30.2	0.020	5.1
	1500	7.62	0.237	59.2	0.046	11.5

**Notes:**

- Ultra-sorb panels with 9" (225 mm) or 12" (300 mm) tube spacings have no measurable air pressure loss.
- Use DRI-STEEM's Dri-calc sizing and selection software to calculate your specific air pressure loss.

### Step 3: Determine the tube spacing

On the **Entering % RH** axis of Figure 19-1, follow the line up from 10 to where it hits the slope for a **Leaving % RH** of 90. Then read horizontally to the right for non-wetting distances at the different tube spacings. A 6" tube spacing will provide a non-wetting distance of 40", while the 9" spacing requires 60". Use 6" spacing (because the entrance to the blower is 42" downstream from the Ultra-sorb).

### Step 4: Verify that tube spacing will provide sufficient capacity

The panel face area is 21 ft<sup>2</sup> (84" × 36"). From Table 19-1, a 6" tube spacing will produce a maximum capacity of 18 lbs/hr/ft<sup>2</sup>. Multiplying 21 ft<sup>2</sup> × 18 lbs/hr/ft<sup>2</sup> = 378 lbs/hr. The maximum load is 336 lbs/hr; therefore, the 6" tube spacing will provide adequate output capacity. Had the 6" tube spacing maximum capacity been lower than 336 lbs/hr, it would have been necessary to select the 3" spacing to satisfy the load.

### Steam absorption considerations

- Non-wetting distance is the dimension downstream from the Ultra-sorb panel leaving side to the point where wetting will not occur, although steam wisps may be present. Solid objects at duct air temperature, such as coils, dampers, fans, etc., downstream of this dimension will remain dry.
- **CAUTION!** Non-wetting distances described in this catalog do not apply when installing an Ultra-sorb panel upstream of filter media. If you need to install an Ultra-sorb upstream of filter media, consult your representative or DRI-STEEM directly for special recommendations.
- Note that the rise in RH (the difference between entering and leaving RH) has a direct bearing on the non-wetting distance. As the rise increases, more vapor needs to be dispersed into the air, which increases the non-wetting distance.
- Uneven airflow over Ultra-sorb cross-section may result in nonuniform steam-and-air mixing, which increases the non-wetting distance.
- See the pressure loss table at left.

# Non-wetting distances

**Figure 19-1:  
Ultra-sorb non-wetting distances**

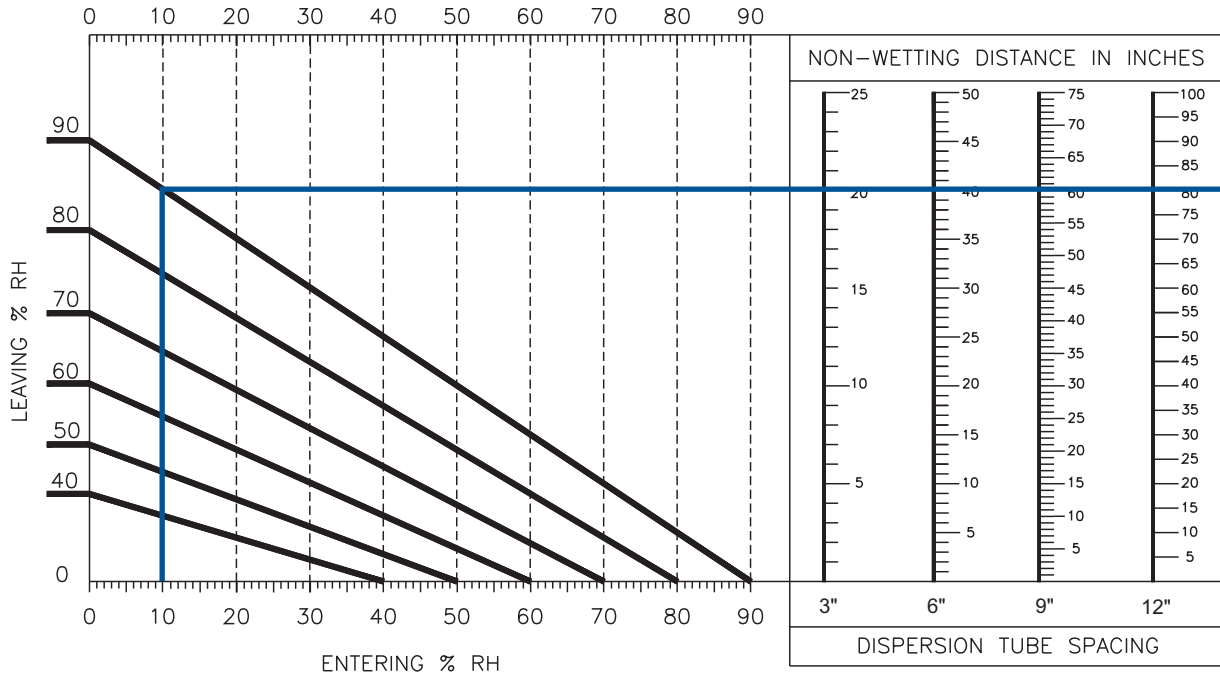

**Note:**  
The above data applies to all air velocities up to 1,500 fpm (7.6 m/s) and are based on air leaving the humidification zone at conditions of 55 °F (13 °C) and the stated % RH.

mc\_100907\_0920

**Table 19-1:  
Ultra-sorb Model LV and LH tube spacing and capacity**

Tube spacing		Maximum capacity	
inches	mm	lbs/hr/ft <sup>2</sup>	kg/h/m <sup>2</sup>
3	75	36	175
6	150	18	88
9	225	12	59
12	300	9	44

**Note:**  
The above steam flow capacity data is based on pounds (kg) of steam per hour per square foot (meter) of face area, exclusive of headers, at various tube spacings.

mc\_010709\_0710

**Table 19-2:  
Ultra-sorb Model XV tube capacity**

Tube spacing	Maximum capacity	
	lbs/hr per tube	kg/h per tube
3" (75 mm)	35	15.8
6" (150 mm)	35	15.8
9" (225 mm)	35	15.8
12" (300 mm)	35	15.8

# Choosing a location for Ultra-sorb

## Determine humidifier placement

Check available non-wetting distance, and review Figure 20-1. Dispersed steam must be absorbed into the airflow before it comes in contact with duct elbows, fans, vanes, filters, or any object that can cause condensation and dripping.

## Placement in an air handling unit

- **Location A is the best choice.** Installing downstream of heating and cooling coils provides laminar flow through the dispersion unit; plus, the heated air provides an environment for best absorption.
- **Location B is the second-best choice.** However, in change-over periods, the cooling coil will eliminate some moisture for humidification.
- **Location C is the third-best choice.** Air leaving a fan is usually very turbulent and can cause vapor to not absorb at the expected non-wetting distance. Allow for more distance if installing downstream of a fan.
- **Location D is the poorest choice.** The cooler air at this location requires an increased non-wetting distance.

**Figure 20-1:**  
Placing a dispersion assembly in an air handling unit

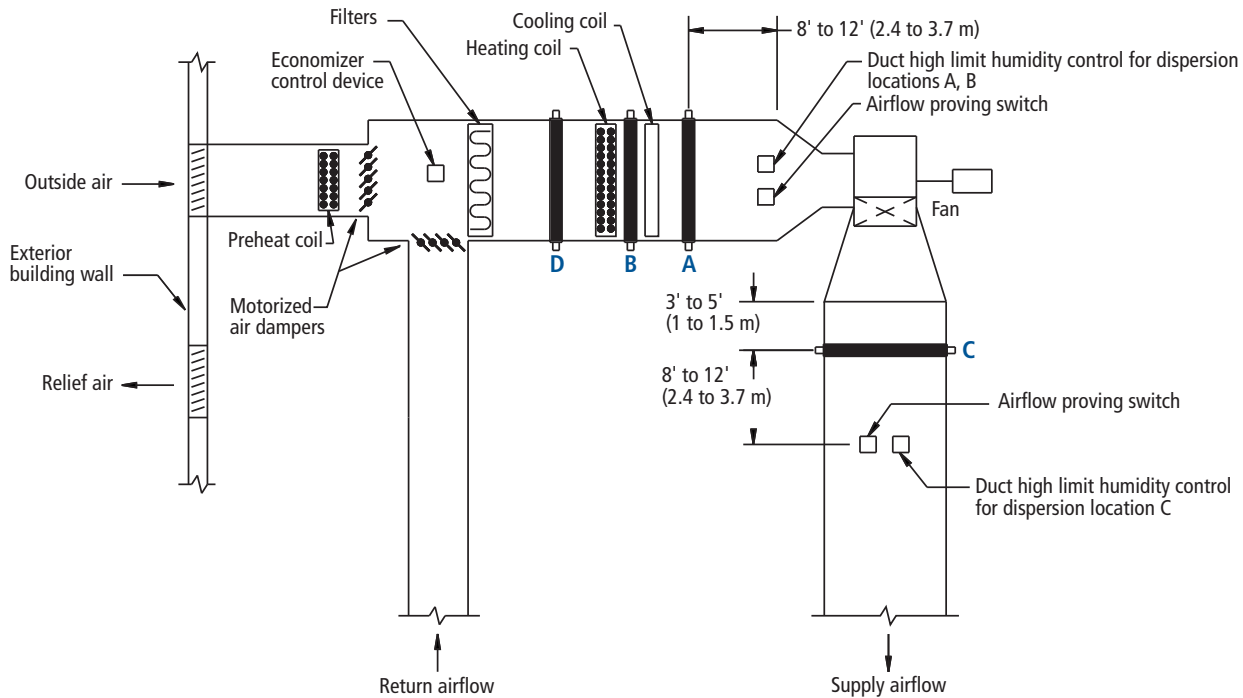

DC-1081

mc\_092507\_1530

# Mounting Ultra-sorb Model XV

**Figure 21-1:  
Ultra-sorb Model XV piping components**

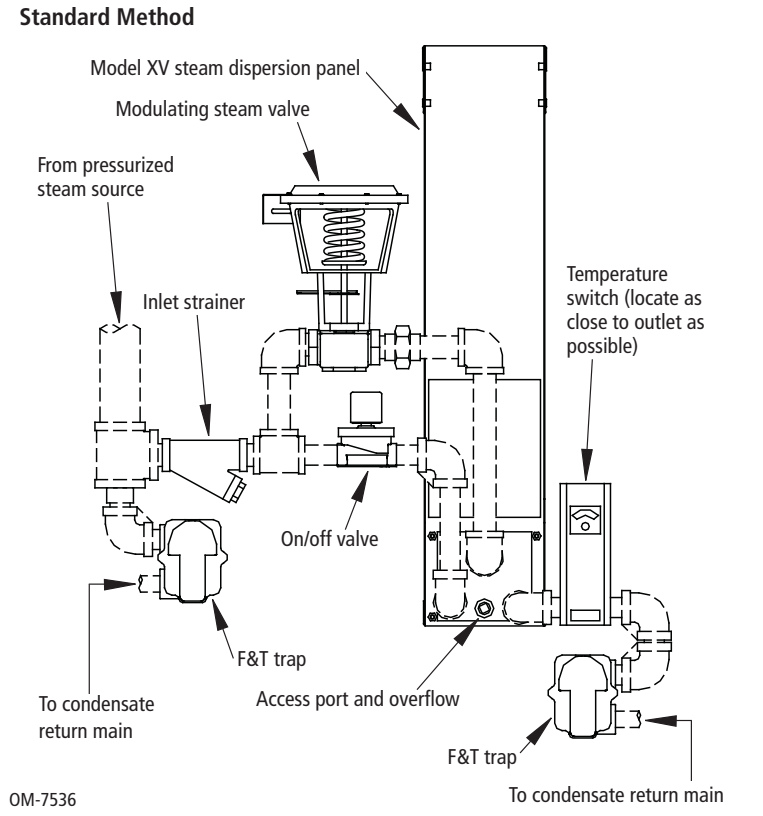

**Figure 21-3:  
Ultra-sorb Model XV piping components**

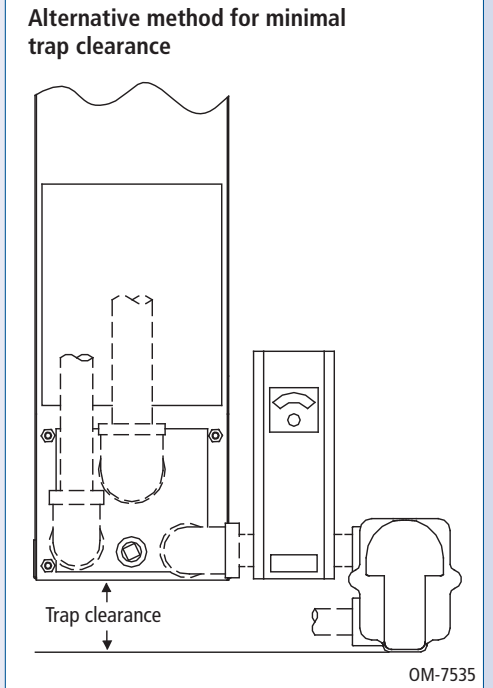

**Figure 21-2:  
Control cabinet for Ultra-sorb Model XV solenoid valve and temperature switch**

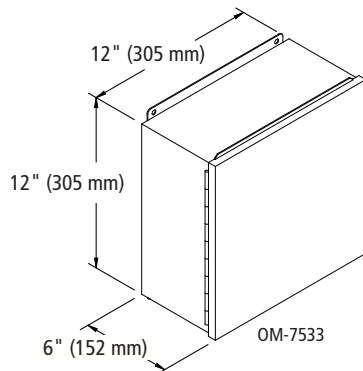

Note:

- Electrical power requirements: 120 VAC, 0.2 Amps, or 240 VAC, 0.1 Amps
- Components are 24 VAC, powered by a transformer in the control cabinet.
- Maximum distance from control cabinet to Ultra-sorb Model XV is 50 feet (15 m).
- Time delay is adjustable from 5 to 100 minutes, factory-set at 30 minutes.

# Mounting Ultra-sorb Model XV

**Figure 22-1:**  
Ultra-sorb Model XV in an air handler

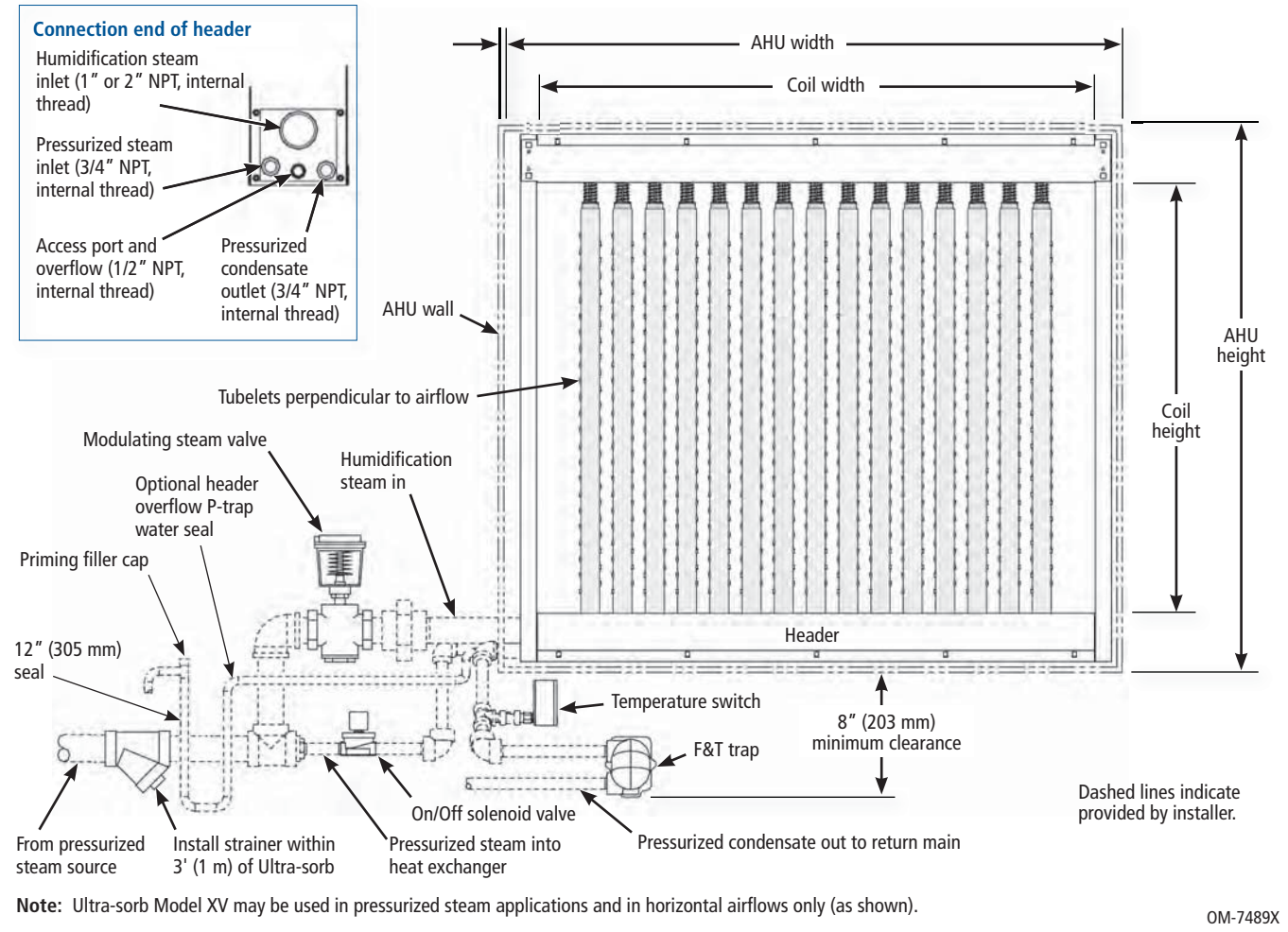

# Mounting Ultra-sorb Model LV in a horizontal airflow (pressurized steam)

**Figure 23-1:**  
**Mounting Ultra-sorb Model LV in a horizontal airflow (pressurized steam application shown)**

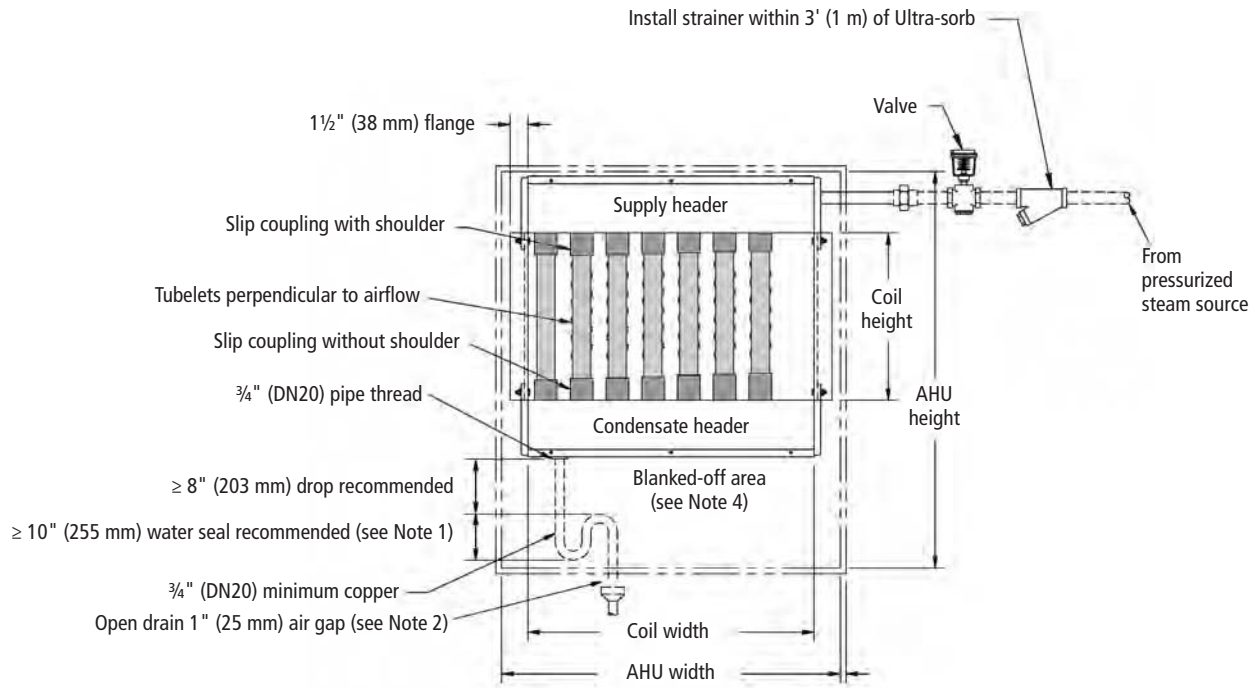

DC-1097

Dashed lines indicate provided by installer.

**Notes:**

1. For pressurized steam applications we recommend installing a 10" (255 mm) minimum water seal or a float and thermostatic (F&T) trap. F&T traps are approximately 7" (180 mm) in height.
2. Locate air gap only in spaces with adequate temperature and air movement to absorb flash steam; otherwise, condensation may form on nearby surfaces. Refer to governing codes for drain pipe size and maximum discharge water temperature.
3. When mounting an Ultra-sorb in a duct, headers and flanges are mounted outside the duct.
4. 100% of the airflow must pass through the Ultra-sorb, which means that any openings surrounding it must be sealed. The blanked-off area below the Ultra-sorb provides clearance height for F&T traps, water seals, and condensate piping connections.

## Mounting Ultra-sorb Model LH in a horizontal airflow (pressurized steam)

**Figure 24-1:**  
**Mounting Ultra-sorb Model LH in a horizontal airflow (pressurized steam applications only)**

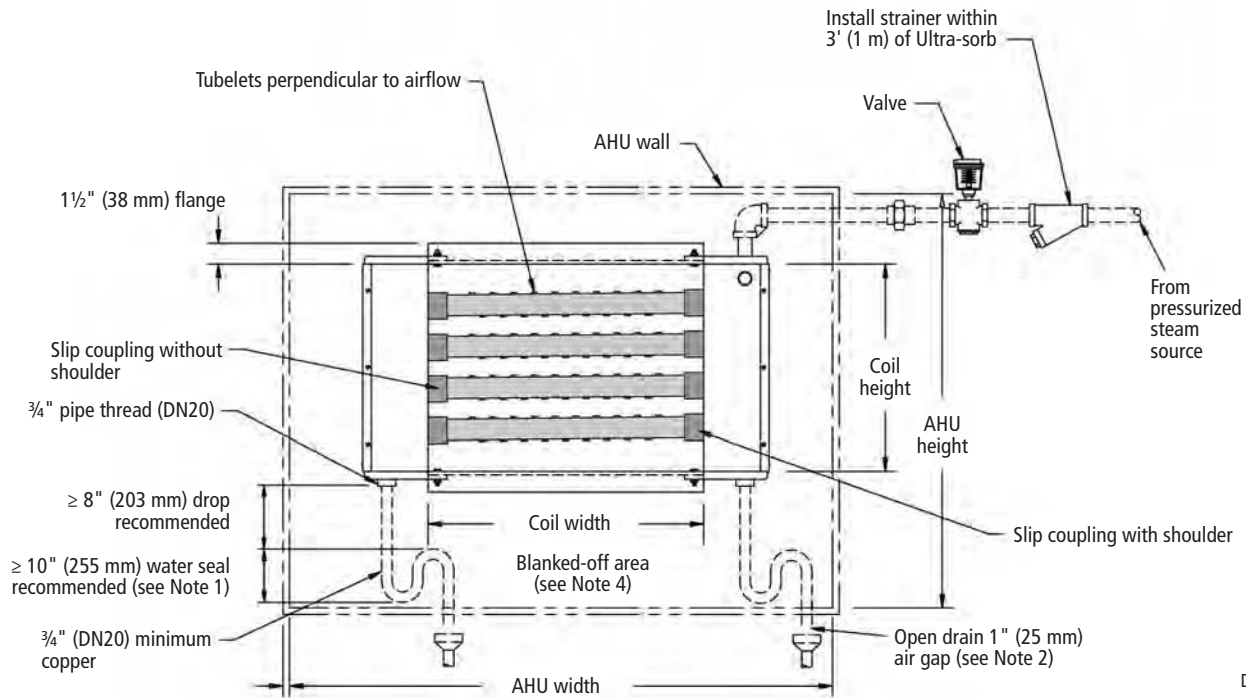

Dashed lines indicate provided by installer.

### Notes:

1. A water seal or trap is required on each condensate line. For pressurized steam applications we recommend installing a 10" (255 mm) minimum water seal or an F&T trap. F&T traps are approximately 7" (180 mm) in height.
2. Locate air gap only in spaces with adequate temperature and air movement to absorb flash steam; otherwise, condensation may form on nearby surfaces. Refer to governing codes for drain pipe size and maximum discharge water temperature.
3. When mounting an Ultra-sorb in a duct, headers and flanges are mounted outside the duct.
4. 100% of the airflow must pass through the Ultra-sorb, which means that any openings surrounding it must be sealed. The blanked-off area below the Ultra-sorb provides clearance height for F&T traps, water seals, and condensate piping connections.

# Mounting Ultra-sorb Model LH in a vertical airflow (evaporative steam)

**Figure 25-1:  
Ultra-sorb Model LH in a vertical airflow (evaporative steam application shown)**

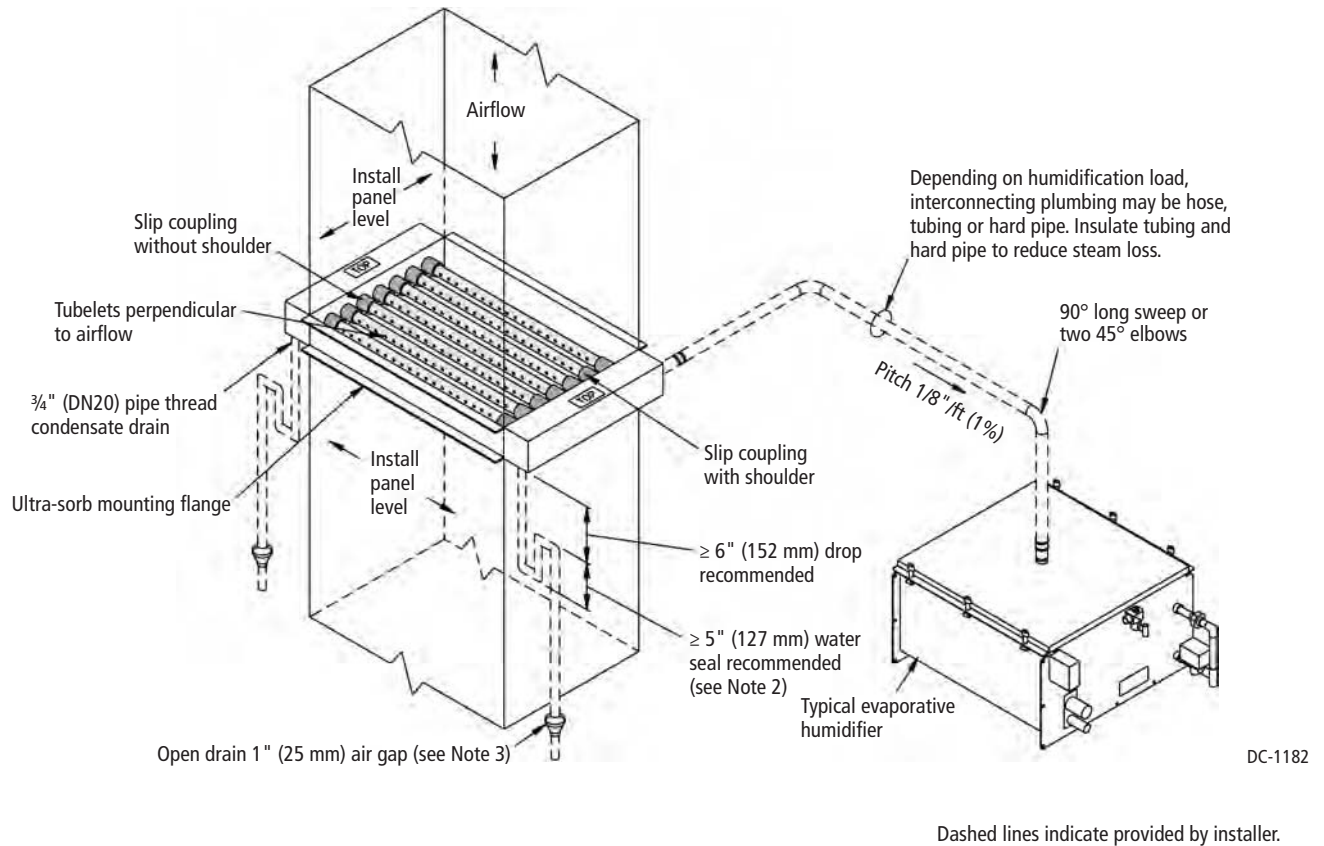

**Notes:**

1. Specify Ultra-sorb Model LH only for vertical airflow applications.
2. A water seal is required on each condensate line.
3. Locate air gap only in spaces with adequate temperature and air movement to absorb flash steam; otherwise, condensation may form on nearby surfaces. Refer to governing codes for drain pipe size and maximum discharge water temperature.
4. When mounting an Ultra-sorb in a duct, headers and flanges are mounted outside the duct.

## Mounting Ultra-sorb Model LH in a vertical airflow (pressurized steam application)

**Figure 26-1:**  
Ultra-sorb Model LH in a vertical airflow (pressurized steam application shown)

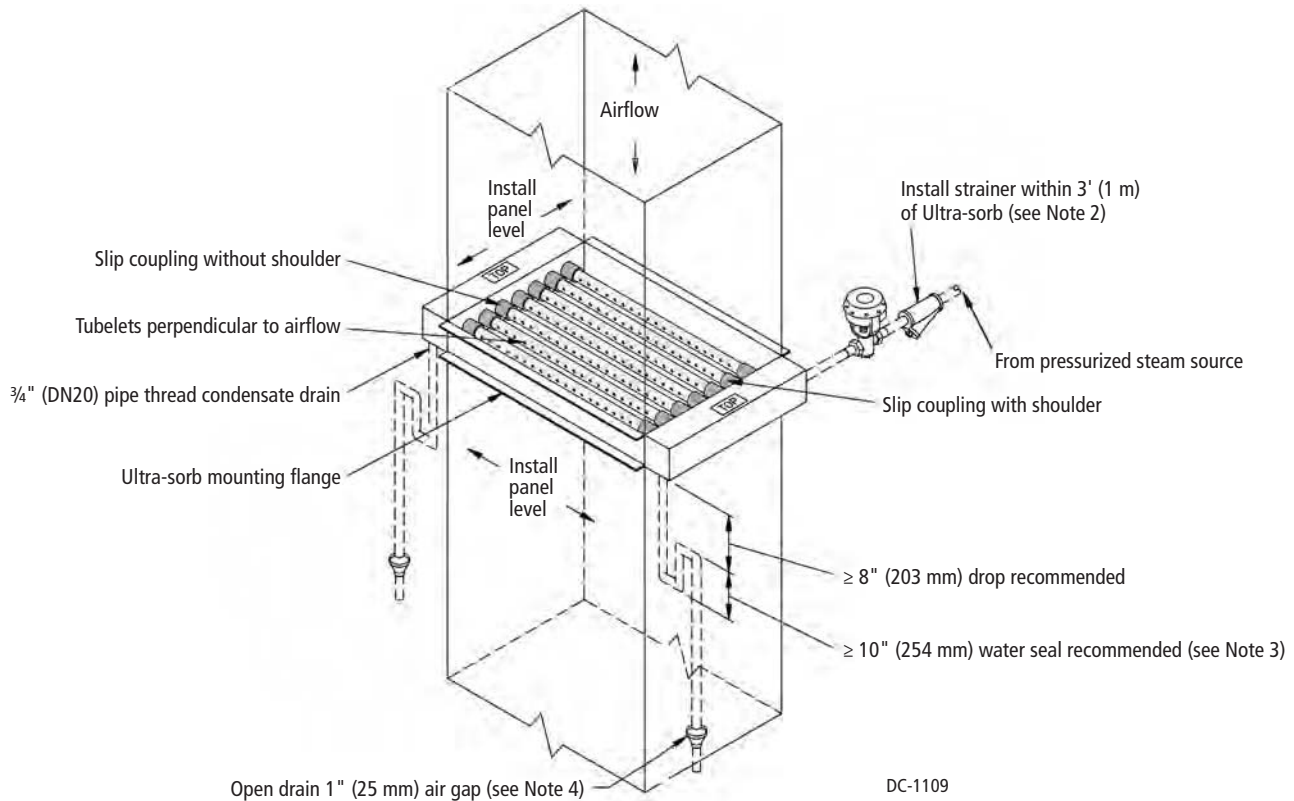

Dashed lines indicate provided by installer.

**Notes:**

1. Specify Ultra-sorb Model LH only for vertical airflow applications.
2. For pressurized steam applications, install a "Y" strainer ahead of the steam valve within 3' (1 m) of the Ultra-sorb.
3. A water seal or trap is required on each condensate line. For pressurized steam applications we recommend installing two 10" (255 mm) minimum water seals or two F&T traps. F&T traps are approximately 7" (180 mm) in height.
4. Locate air gap only in spaces with adequate temperature and air movement to absorb flash steam; otherwise, condensation may form on nearby surfaces. Refer to governing codes for drain pipe size and maximum discharge water temperature.
5. When mounting an Ultra-sorb in a duct, headers and flanges are mounted outside the duct.

# Piping to an Ultra-sorb

## From an evaporative humidifier to an evaporative dispersion panel

**Table 27-1:**  
Maximum steam carrying capacity and length of interconnecting vapor hose, tubing, and pipe\*

Vapor hose <sup>†††</sup>						Copper or stainless steel tubing and Schedule 40 steel pipe					
Hose I.D.		Maximum capacity		Maximum length <sup>**</sup>		Tube or pipe size <sup>***</sup>		Maximum capacity		Maximum developed length <sup>†</sup>	
inches	DN	lbs/hr	kg/h	ft	m	inches	DN	lbs/hr	kg/h	ft	m
1½	40	150	68	10	3	1½	40	150	68	20	6
2	50	250	113	10	3	2	50	220	100	30	9
See pages 22-26 for connection drawings.						3 <sup>††</sup>	80 <sup>††</sup>	450	204	80	24
						4 <sup>††</sup>	100 <sup>††</sup>	750	340	100	30
						5 <sup>††</sup>	125 <sup>††</sup>	1400	635	100	30
						6 <sup>††</sup>	150 <sup>††</sup>	2300	1043	100	30

- \* Based on total maximum pressure drop in hose, tubing, or piping of 5" wc (1244 Pa)
- \*\* Maximum recommended length for vapor hose is 10' (3 m). Longer distances can cause kinking or low spots.
- \*\*\* To minimize loss of capacity and efficiency, insulate tubing and piping.
- † Developed length equals measured length plus 50% of measured length to account for pipe fittings.
- †† Requires flange connection
- ††† When using vapor hose, use DRI-STEEM vapor hose for best results. Field-supplied hose may have shorter life and may cause foaming in the evaporating chamber resulting in condensate discharge at the dispersion assembly. Do not use vapor hose for outdoor applications.

## From a pressurized steam source to an Ultra-sorb Model XV

**Figure 27-1:**  
Ultra-sorb Model XV piping

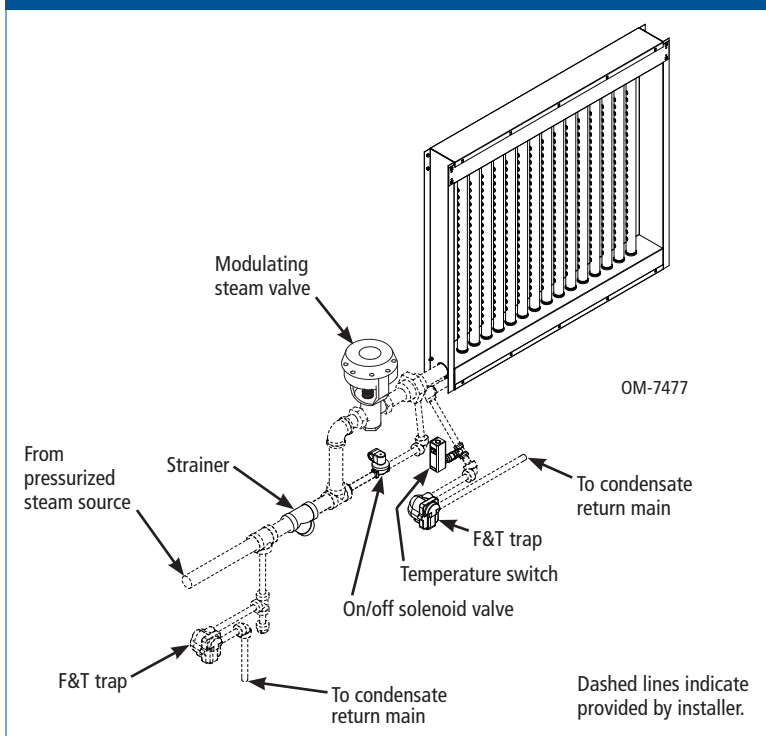

**Table 27-2:**  
Maximum steam carrying capacity and length of interconnecting copper or stainless steel tubing and Schedule 40 steel pipe\*

Tube or pipe size <sup>**</sup>		Maximum capacity		Maximum developed length <sup>†</sup>	
inches	DN	lbs/hr	kg/h	ft	m
1½	40	150	68	20	6
2	50	220	100	30	9
3 <sup>††</sup>	80 <sup>††</sup>	450	204	80	24
4 <sup>††</sup>	100 <sup>††</sup>	750	340	100	30
5 <sup>††</sup>	125 <sup>††</sup>	1400	635	100	30
6 <sup>††</sup>	150 <sup>††</sup>	2300	1043	100	30

- \* Based on total maximum pressure drop in hose, tubing, or piping of 5" wc (1244 Pa)
- \*\* To minimize loss of capacity and efficiency, insulate tubing and piping.
- † Developed length equals measured length plus 50% of measured length to account for pipe fittings.
- †† Requires flange connection

## Ultra-sorb supply and drain connections

**Figure 28-1:**  
F&T trap dimensions (Models LV and LH)

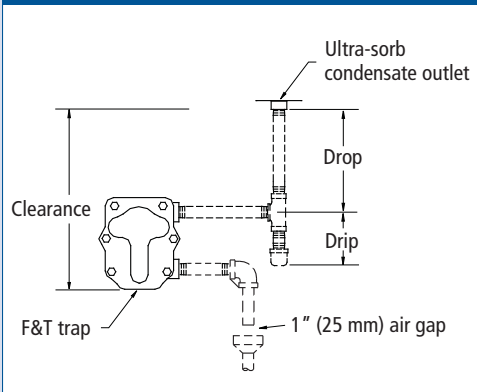

**Table 28-1:**  
Condensate piping for Ultra-sorb steam dispersion panels

	Models LV and LH		Model XV
	Evaporative steam	Pressurized steam	
P-trap water seal (see Figure 29-2)	Drop: 6" (150 mm) Seal: 5" (130 mm)	<u>Recommended:</u> Drop: 8" (205 mm) Seal: 10" (255 mm)	NA
F&T trap (see Figure 28-3)	No	<u>Alternate: *</u> Drop: 12" (305 mm) Drip: 4" (105 mm)	Provide 8" (205 mm) clearance below header
Inverted bucket trap	No	No	No
Stainless steel thermostatic trap	No	No	No
Condensate to open drain	Yes	Yes	NA
Condensate return by condensate pump	Yes	Yes	NA
Condensate return to humidifier by gravity	Yes	NA	NA
Condensate return to boiler via return line	NA	No	Yes (no additional pumps, valves, or controls)
Clean steam	Use stainless steel components.		No

\* Provide 18" (460 mm) vertical clearance for future P-trap substitution if required.

# Ultra-sorb supply and drain connections

From a pressurized steam source to an Ultra-sorb Model LV or LH

**Figure 29-1:**  
Connection to a boiler (pressurized steam applications)

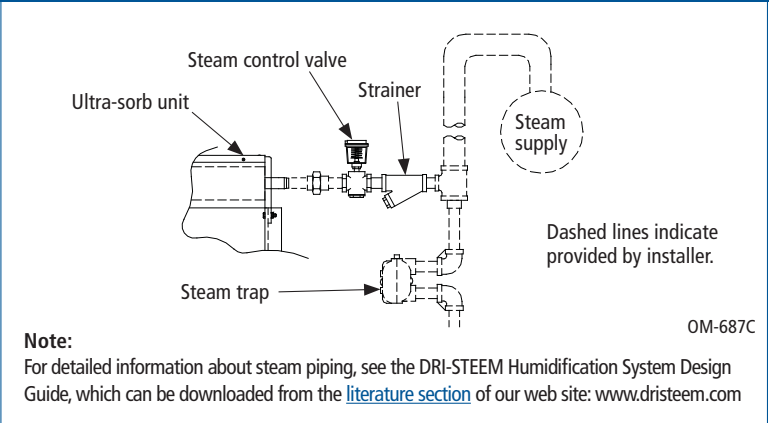

**Figure 29-2:**  
P-trap water seal dimensions (Models LV and LH)

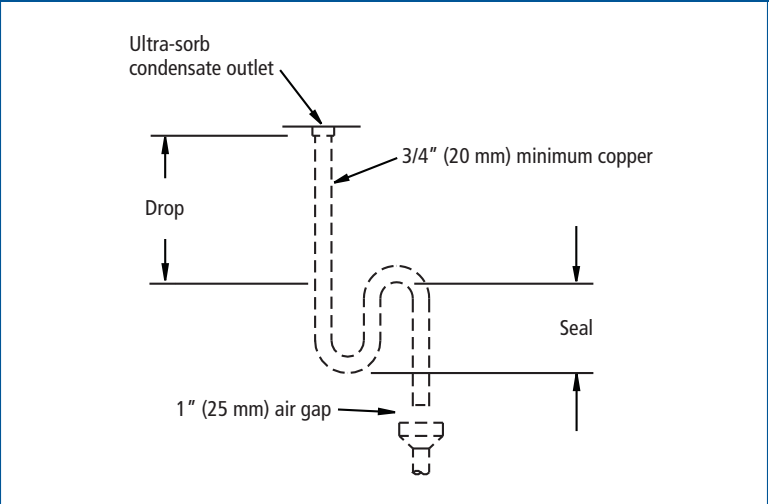

**Figure 29-3:**  
Lifting condensate (Models LV and LH)

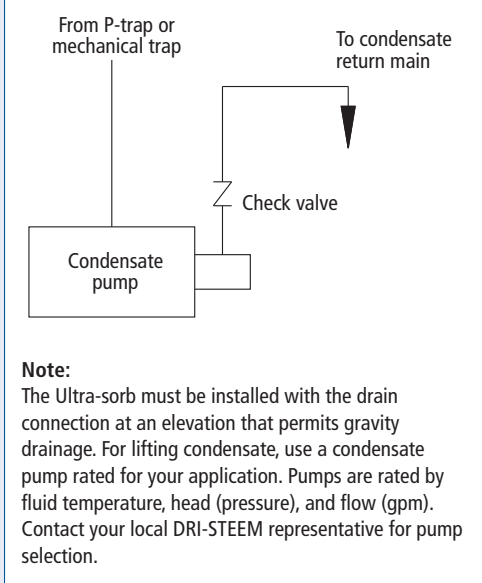

## High-efficiency tube retrofit option

### Retrofitting is easy!

#### Remove the existing tubes

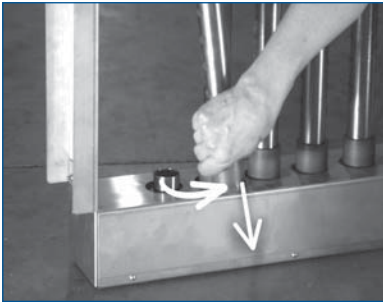

#### Install the high-efficiency tubes

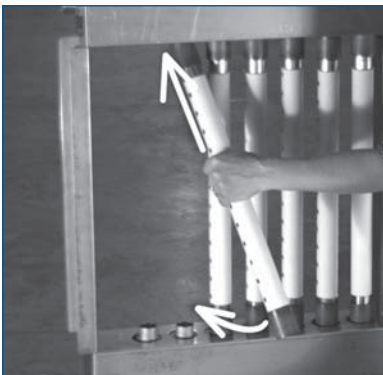

*The energy saved by a DRI-STEEM dispersion panel with high-efficiency tubes will more than make up for the cost of replacing any uninsulated steam dispersion assembly.*

### Engineered for existing dispersion systems

DRI-STEEM's high-efficiency dispersion tubes are available as a retrofit option for existing Ultra-sorb Models LV and LH and Rapid-sorb® steam dispersion assemblies.

Energy efficiencies and water savings not previously available are now possible as upgrades to currently installed steam dispersion panels.

### Excellent payback possibilities

Retrofit high-efficiency tubes have short payback — usually less than two years.

### Ordering and retrofitting are easy

Instructions are provided in the *High-efficiency Tube Option Retrofit Flyer* on the DRI-STEEM web site ([www.dristeem.com](http://www.dristeem.com)). For the flyer, just search the site for “retrofit” or [click here](#).

**DRI-STEEM® High-efficiency Dispersion Tube Payback Estimator**

City nearest your location:

Natural gas rate (\$/1000Cu Ft-\$/therm x 10):

Electric rate:

Water rate:

District Steam rate:

750 FPM Feet Per Minute Airflow:

Select "New Time humidifier and To manually set humidifier run time, select

**Estimated Retrofit Payback**

Based on TMY2 data using 5274 run hours:		Using manually entered 6000 run hours:	
\$9,656 Per Year	0.88 Years	Electric	0.77 Years \$10,985 Per Year
\$4,333 Per Year	1.96 Years	Gas	1.73 Years \$4,930 Per Year
\$3,034 Per Year	2.81 Years	District Steam	2.47 Years \$3,452 Per Year
32,870 Gallons/yr saved!		Water	37,395 Gallons/yr saved!
\$148 Per Year			\$168 Per Year
52 lbs water & 50,878 btu/hr saved!			59 lbs water & 57,883 btu/hr saved!
Electric = 121,135 lbs CO2/yr		Carbon Dioxide Reductions	Electric = 137,813 lbs CO2/yr
Gas = 37,376 lbs CO2/yr			Gas = 42,521 lbs CO2/yr

**Call now**

For an application-specific payback analysis, contact DRI-STEEM at 800-328-4447 or your local DRI-STEEM Representative.

# Steam injection, generation, control, and dispersion

DRI-STEEM's humidification systems generate, control, and disperse steam and provide accurate RH control. Humidification system design factors include energy source, steam non-wetting distance, humidification load, make-up water type, control options, in-house boilers, and building construction.

See the [Products](#) page at [www.dristeem.com](http://www.dristeem.com) for more information, or click on the photo captions to the right.

## Boiler steam humidifiers

DRI-STEEM offers standard Steam Injection humidifiers for applications where short non-wetting distance is not critical. They use on-site or district steam and are adaptable to virtually any size application.

## Electric humidifiers

Electric humidifiers can be installed in a variety of applications and mounting configurations. DRI-STEEM electric humidifiers are compatible with a wide range of RH control options and water types and encompass a wide range of capacities and steam distribution methods.

## Gas humidifiers

The key benefit of gas-fired humidifiers is the lower energy cost compared to electric. DRI-STEEM's gas-to-steam (GTS) humidifier is the industry's first and best-selling gas-fired humidifier. The broad capacity range and precise control make GTS the ideal choice for almost any application.

## Heat exchanger humidifiers

DRI-STEEM's steam-to-steam (STS) and liquid-to-steam (LTS) humidifiers are economical, using heat from steam boilers or hot liquid boilers to produce high-quality, chemical-free steam. They are compatible with all water types: tap, softened, deionized, and reverse osmosis.

## Controllers, accessories, and options

DRI-STEEM's humidification system controllers, accessories, and options expand system performance and flexibility. Comprehensive microprocessor-based control and diagnostics, drain water tempering, high-efficiency dispersion tubes, outdoor enclosures, weather covers, and custom rack systems are some of the ways DRI-STEEM makes small and large humidification systems more flexible during installation and more robust after startup.



[Boiler steam humidifiers](#)



[Electric humidifiers](#)



[GTS humidifier](#)



[STS and LTS humidifiers](#)



[Heated/ventilated Outdoor enclosure](#)

### Expect quality from the industry leader

For more than 40 years, DRI-STEEM has been leading the industry with creative and reliable humidification solutions. Our focus on quality is evident in the construction of the Ultra-sorb, which features stainless steel construction and an industry-leading Two-year Limited Warranty.

### For more information

[www.dristeem.com](http://www.dristeem.com)  
sales@dristeem.com

For current product information, please see the [literature section](#) of our web site.

### DRI-STEEM Corporation

An ISO 9001:2000 certified corporation.

#### U.S. Headquarters:

14949 Technology Drive  
Eden Prairie, MN 55344  
800-328-4447  
952-949-2415  
952-229-3200 (fax)

#### European office:

Marc Briers  
Grote Hellekensstraat 54 b  
B-3520 Zonhoven  
Belgium  
+3211823595 (voice)  
+3211817948 (fax)  
E-mail: marc.briers@dristeem.com

Continuous product improvement is a policy of DRI-STEEM Corporation; therefore, product features and specifications are subject to change without notice.

DRI-STEEM, Drane-kooler, Dri-calc, GTS, LTS, STS, Vapormist, Vaporstream, Rapid-sorb, and Ultra-sorb, are registered trademarks or trademarks of DRI-STEEM Corporation, and are filed for trademark registration in Canada and the European community.

Ultra-sorb is covered by the following Patents, with additional patents pending: United States Patent numbers 5,126,080; 5,277,849; 5,372,753; 5,376,312; 5,543,090

© 2009 DRI-STEEM Corporation



Form No. US-CAT-0209



### Dri-calc

DRI-STEEM's Dri-calc® software will size loads, select equipment, write specifications, generate as-configured installation guides, and create equipment schedules.



Visit the [Dri-calc page](#) at [www.dristeem.com](http://www.dristeem.com) to request a free copy of Dri-calc.

### Drane-kooler

The Drane-kooler™ mixes cold water with hot discharge water to reduce the water temperature before it enters the drain system. This complies with code requirements and prevents damage to PVC drain piping.



Visit the [Drane-kooler page](#) at [www.dristeem.com](http://www.dristeem.com).

### Humidifier De-scaling solution

Keep your humidifier operating at peak efficiency with DRI-STEEM Humidifier De-scaling Solution. The De-scaling Solution cleans without corroding humidifier tanks or welds.



Visit the [Humidifier De-scaling Solution page](#) at [www.dristeem.com](http://www.dristeem.com)

Your [DRI-STEEM representative](#) is: