

Pennant[®]

The Easy Choice



LAARS[®] 
Heating Systems Company
A subsidiary of **BRADFORD WHITE[™]** Corporation

Easy to install, easy to maintain and easy to use.

For more than 50 years, the LAARS brand has stood for quality, reliability, and innovation in heating system design. Now, Pennant builds on that tradition with an outstanding line of commercial boilers/heaters designed for today's most demanding indoor and outdoor environments. The Pennant line of fan-assisted, modular boilers and water heaters from LAARS ranks among the industry's most versatile and environmentally friendly commercial systems for hydronic and hot water applications. Available in 7 sizes from 500 to 2000 MBTU/h, Pennant boilers and water heaters run reliably on natural or LP gas and deliver efficiency levels up to 85%. Pennant systems are also among the "greenest" in the industry with NOx emissions below 10 ppm.

Pennant boilers and water heaters feature convenient, modular construction that separates the burner trays, gas train, and blower assembly. All Pennant models use lightweight insulation, glass-lined cast iron or bronze headers, and non-ferrous waterways. The 10 tube heat exchanger design uses finned tubing for the quickest and most efficient heat transfer and the water heater meets the ASHRAE 90.1 standard for efficiency for use with storage tanks. Pennants are also available with copper or cupronickel heat exchanger tubing for use in various water and flow rate conditions, and may include optional factory-mounted pumps sized for the heat exchanger and 30 feet of piping.

With superior overall construction and high-efficiency combustion, Pennant can cut fuel costs significantly compared to conventional water heating systems, and the savings can amount to thousands of dollars over the life of the equipment.

Easy to Install

The modular construction makes Pennant units easy to install and maintain. Water connection may be reversed to accommodate left or right side piping.

The sealed combustion system is fan-assisted and uses either ambient room air, or air from the outside ducted directly to the unit. This allows the Pennant to be vented as a Category I or Category III appliance. Category I fan-assisted appliances allow for smaller diameter vents than natural draft units, but can still be vented with standard B-vent. When the Pennant is vented horizontally, as a Category III appliance, it uses AL29-4C stainless steel. It may be vented horizontally up to 50 feet with three elbows

without the addition of external vent fans. Vent and combustion air connections can be located on the top or the back of the unit, in any combination, and every unit has a long-lasting, washable air filter to keep the burner clean, ensuring its long life.

Pennant boilers make installation easier by providing a control system that gives installers several different modes of operation that are selected with the touch of a button. These modes allow the installer to choose the mode that best matches the needs of the system. Modes include settings for primary/secondary piping, DHW storage tank systems, B.A.S. controls and other common applications.

Easy to Maintain

Ongoing maintenance of Pennant is easy. The burner assembly features modular burner trays to ensure perfect alignment of orifices and burners, gas manifolds mount on the burner flange, and the burner flanges seal to the air box. In addition, the entire gas train can be easily removed and the heat exchanger simply lifts out from the top or front of the unit. The air filter is a breeze to clean...just wash it with soap and water.

Controls are also service-friendly with clean and simple wiring and are readily accessible in a slide-out drawer. All models have a convenient front-access panel with status indicator lights to monitor power, call for heat, pump on, ignitor on, gas valve open, and lock out.



**Modular construction,
compliant end-walls and
non-ferrous waterways**



Top or rear vent and combustion air connections



Easy access ignitor

Flexible Venting

- Category III (horizontal) venting, up to 50 feet with 3 elbows, without additional fans
- Fan-assisted Category I venting with standard B-vent
- Combustion air can be taken from room, or ducted to the unit from the outside
- Top or rear vent and combustion air connections

Easy Maintenance

- Heat exchanger is easily removed from top or front
- Washable air filter
- Clean wiring layout makes electrical troubleshooting easy
- Easy access to ignitor via special service panel
- Easy-to-service burner assembly
- LAARS hidden fastener jacket (HFJ) system reduces time and effort for teardown and assembly
- Service-friendly slide-out control panel

Dimensional Data

Dimensions shown in inches, cm.

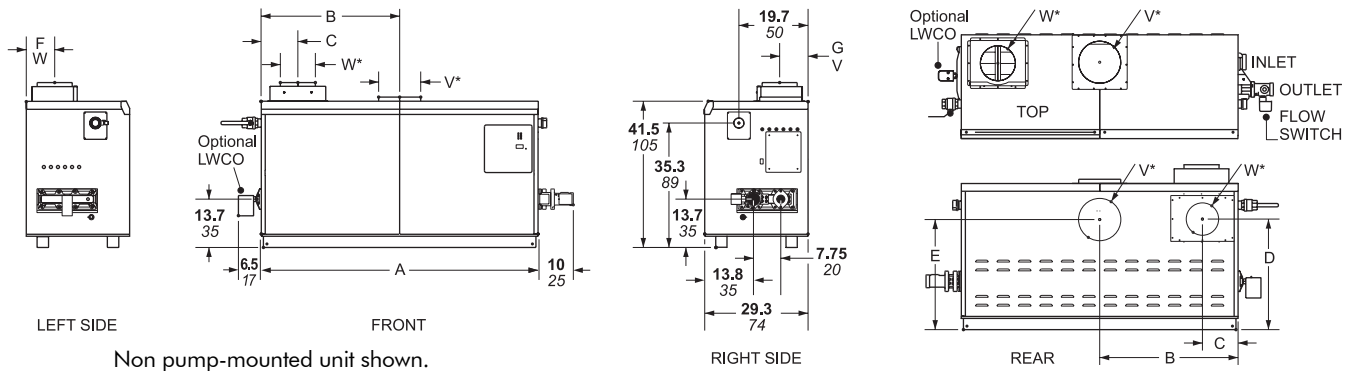

Size	A	B	C	D	E	F	G	Air Conn. W*	Vent Conn. V*	Horiz. Vent										
500	33½	85	15¾	40	5¾	15	29¾	76	32¾	83	7¾	20	8¾	22	6	15	8	20	6	15
750	45½	116	21¾	55	5¾	15	29¾	76	32¾	83	7¾	20	8¾	22	6	15	10	25	8	20
1000	57½	146	28¾	73	5¾	15	29¾	76	32¾	83	7¾	20	7	18	8	20	10	25	8	20
1250	68	172	34	86	10⅛	26	30¾	78	29½	75	8¾	22	8¾	22	8	20	12	30	8	20
1500	78½	199	39¾	101	10⅛	26	30¾	78	29½	75	8¾	22	8¾	22	8	20	12	30	8	20
1750	89	226	44½	113	10⅛	26	30¾	78	29½	75	8¾	22	8¾	22	8	20	14	36	8	20
2000	99½	253	49¾	126	10⅛	26	30¾	78	29½	75	8¾	22	8¾	22	12	30	14	36	12	30

*Air and vent connections may be on top or back of the Pennant, and are field convertible. Dimensions shown in inches cm.

Easy to Use

All Pennant water heater/boilers are built to operate effectively at up to 10,000 feet, in harsh environments from -40° to +140°F, and to withstand thermal shock down to 30°F. Pennant boilers can be used with up to a 50:50 glycol to water mix and waterways can operate in water with a hardness up to 17 gpg. Pennant units feature compliant end walls to accommodate thermal expansion. Status lights and the control display easily show the Pennant's operating status.

The Pennant is the easy choice. With Pennant's high efficiency, operating costs are minimized. Pennant's performance and low maintenance delivers the savings!

Features Summary

Unmatched Performance

- Applications for Hydronic and Domestic Hot Water
- Up to 85% efficiency
- NOx below 10 ppm
- 2-stage, 3-stage, and 4-stage firing
- Immune to thermal shock down to 30°F
- Operates in altitudes up to 10,000 feet
- Ambient temperatures from -40°F to +140°F
- Tolerant of glycol systems
- Waterways able to operate in a maximum water hardness of 17 gpg
- Hydronic Models supply temps from 125°F to 220°F
- Gas supply right or left side (field convertible)
- Volume Water Heater models supply temps from 125°F to 210°F
- Maintains efficiency and low NOx levels at all stages of firing
- Model sizes: (2-Stage) 500, 750, (3-Stage) 1000, (4-Stage) 1250, 1500, 1750, 2000
- Optional factory-mounted pump sized for heat exchanger, 30 feet of pipe and 3 elbows total pressure drop
- Fan-assisted combustion system
- 120vac, 60 Hz single phase power
- Front access panel with status indicator lights
- User-friendly programmable control to 6 modes
- BAS interface
- May be ordered with left or right-hand piping connection



Front access panel with status indicator lights, 6 mode programmable control, and slide out tray



BAS Interface

Durable, Long-Lasting Construction

- Modular construction: burner trays, gas train, blower assembly
- Glass-lined cast iron or bronze headers
- Heat exchanger uses efficient 10 finned-tube design
- Lightweight insulation
- Construction suitable for rack mounting up to 2 boilers
- Compliant end-walls to accommodate thermal expansion
- Non-ferrous waterways to meet standards for volume water heaters
- Backed by LAARS warranty and superior customer service
- Two Pennants may be rack-mounted to save valuable floor space

Sizing Data

Indoor Model	Input ^{1,3} BTU/H x1000	Output ^{1,3} BTU/H x1000	IBR Net ¹ Rating BTU/H x1000	Firing Rate	Gas Conn. inches	Water Conn. inches	Shipping Weight ² lbs. kg
500	500	425	361	2-Stage	1¼	2	425 193
750	750	638	542	2-Stage	1¼	2	505 229
1000	999	849	722	3-Stage	1½	2½	615 279
1250	1250	1063	903	4-Stage	2	2½	675 306
1500	1500	1275	1084	4-Stage	2	2½	760 345
1750	1750	1488	1264	4-Stage	2	2½	825 375
2000	1999	1699	1444	4-Stage	2	2½	955 434

NOTES: 1. Input and output must be derated 4% per 1000 feet above sea level when installed above 2000 feet altitude.

2. Units with pumps: Add 55 lbs. (25kg).

3. For other boiler ratings:

$$\text{Boiler Horsepower: HP} = \frac{\text{Output}}{33,475} \quad \text{Radiation Surface: EDR sq. ft.} = \frac{\text{Output}}{150} \quad \text{IBR sq. ft.} = \frac{\text{Net IBR Rating}}{150}$$

Water Flow Requirements/Boiler Temperature Rise in Degrees

Indoor Model	20°F		11°C		25°F		14°C		30°F		17°C		35°F		19°C	
	Flow gpm	H/L feet	Flow lpm	H/L m	Flow gpm	H/L feet	Flow lpm	H/L m	Flow gpm	H/L feet	Flow lpm	H/L m	Flow gpm	H/L feet	Flow lpm	H/L m
500	43	1.7	161	0.5	34	1.1	129	0.3	28	0.9	107	0.3	24	0.7	92	0.2
750	64	3.3	241	1.0	51	2.3	193	0.7	43	1.7	161	0.5	36	1.2	138	0.4
1000	85	5.0	321	1.5	68	3.6	257	1.1	57	3.1	214	0.9	48	2.2	184	0.7
1250	106	8.1	401	2.5	85	6.1	322	1.9	71	4.7	269	1.4	61	3.4	231	1.0
1500	128	10.0	483	3.0	102	7.2	386	2.2	85	5.5	322	1.7	73	4.2	276	1.3
1750	N/R	N/R	N/R	N/R	119	10.5	451	3.2	99	8.4	375	2.6	85	5.8	322	1.8
2000	N/R	N/R	N/R	N/R	136	12.5	515	3.8	113	10.4	429	3.2	97	8.3	368	2.5

Headloss/Water Heater Headloss shown is for Pennant heat exchanger only

Indoor Model	Hard Water				Normal Water				Soft Water			
	Flow gpm	H/L feet	Flow lpm	H/L m	Flow gpm	H/L feet	Flow lpm	H/L m	Flow gpm	H/L feet	Flow lpm	H/L m
500	90	3.5	341	1.1	68	2.3	257	0.7	45	1.8	170	0.5
750	90	6.0	341	1.8	68	3.0	257	0.9	45	2.1	170	0.6
1000	90	6.1	341	1.9	68	3.6	257	1.1	45	2.3	170	0.7
1250	90	6.3	341	1.9	68	3.8	257	1.2	68	3.9	257	1.2
1500	90	6.5	341	2.0	68	3.9	257	1.2	68	3.9	257	1.2
1750	90	6.7	341	2.0	68	4.0	257	1.2	68	4.0	257	1.2
2000	112	10.0	424	3.0	112	10.0	424	3.0	112	10.0	424	3.0

Clearances

Appliance Surface	Required to Combustible Material	Suggested Service Access
Left Side	1" 2.5 cm	24" 61 cm
Right Side	1" 2.5 cm	24" 61 cm
Top	1" 2.5 cm	12" 30 cm
Back*	1" 2.5 cm	12" 30 cm
Front	1" 2.5 cm	36" 91 cm
Vent	Per venting system supplier's instructions	
*When vent or air is connected to the back, 36" (91cm) is suggested.		

Recovery Data/Water Heater Water Temperature Rise in Degrees

Indoor Model	40°F	22°C	50°F	28°C	60°F	33°C	70°F	39°C	80°F	44°C	90°F	50°C	100°F	56°C	120°F	67°C	140°F	78°C
	gph	L/h	gph	L/h	gph	L/h	gph	L/h	gph	L/h	gph	L/h	gph	L/h	gph	L/h	gph	L/h
500	1276	4821	1020	3857	850	3214	729	2755	638	2411	567	2143	510	1929	425	1607	364	1378
750	1913	7232	1531	5786	1276	4821	1093	4133	957	3616	850	3214	765	2893	638	2411	547	2066
1000	2548	9633	2039	7707	1699	6422	1456	5505	1274	4817	1133	4281	1019	3853	849	3211	728	2752
1250	3189	12054	2551	9643	2126	8036	1822	6888	1594	6027	1417	5357	1276	4821	1063	4018	911	3444
1500	3827	14464	3061	11571	2551	9643	2187	8265	1913	7232	1701	6429	1531	5786	1276	4821	1093	4133
1750	4464	16875	3571	13500	2976	11250	2551	9643	2232	8438	1984	7500	1786	6750	1488	5625	1276	4821
2000	5099	19276	4080	15421	3400	12851	2914	11015	2550	9638	2266	8567	2040	7710	1700	6425	1457	5507

Note: gph = gallons per hour, L/h = liters per hour.

PENNANT[®]

LAARS Heating Systems Company has stood for quality, reliability, and innovation in heating system design for more than 50 years.

Pennant builds on that tradition with an outstanding line of commercial boilers/water heaters designed for today's most demanding indoor and outdoor environments.



Customer Service, Service Advisors

800.900.9276
800.559.1583 Fax

Applications Engineering

603.335.6300
603.335.3355 Fax

20 Industrial Way
Rochester, NH 03867

International Sales

1869 Sismet Road
Mississauga, Ontario
Canada L4W 1W8
905.238.0100
905.366.0130 Fax

www.Laars.com



Dimensions and specifications subject to change without notice in accordance with our policy of continuous product improvement.

Litho in U.S.A. © Laars Heating Systems Company 0808 Document 1182F