

E - SERIES

SUITABLE FOR FIRETUBE, FIREBOX AND WATERTUBE APPLICATIONS

- Energy Efficient Technology
- High Turndown
- 30 PPM Low NOx with FGR
- 8.4 - 63.0 MMBtu Input Range
- UL & cUL Listed



**INDUSTRIAL
COMBUSTION**

INNOVATION FUELING PERFORMANCE

E - SERIES SPECIFICATIONS

FEATURES:

- Gas and light oil fuels
- Standard emissions & Low NOx capabilities
- Up to 10:1 turndown on natural gas, 8:1 turndown on light oil
- Advanced control options include Parallel Positioning, O₂ trim, variable speed drives and more.
- Low pressure drop head design
- Low motor horsepower for increased energy efficiency
- Hinged combustion head for easy access and maintenance
- UL & cUL listed through model E-252 including many advanced control options

CAPACITIES & SPECIFICATIONS:

	Size 1				Size 2			Size 3				Size 4	
Burner Sizes	84	105	126	147	168	210	252	294	336	378	420	504	630
Gas Input (MBtu/hr)	8,400	10,500	12,600	14,700	16,800	21,000	25,200	29,400	33,600	37,800	42,000	50,400	63,000
Oil Input (US gph)	60.0	75.0	90.0	105.0	120.0	150.0	180.0	210.0	240.0	270.0	300.0	360.0	450.0
Boiler HP @ 80% Eff.	200	250	300	350	400	500	600	700	800	900	1,000	1,200	1,500
Blower Motor HP	3	5	5	7.5	10	15	15	15	20	20	25	40	75
Furnace Pressure ("W.C.)	3	3	3	3	5	5	5	6	6	6	6	8	8

Notes:

1. Firing rates based on 60 cycle and an altitude up to 2,000 ft. above sea level. For blower wheel and motor sizes at higher altitudes, and 50 cycle applications, consult factory.
2. Oil input based on No. 2 oil @ 140,000 Btu/gal
3. Gas input based on Natural Gas @ 1,000 Btu/cu.ft. and 0.60 specific gravity.
4. Lower furnace pressures may reduce motor HP requirements.
5. Boiler overall efficiency of 80% estimated.

DIMENSIONS:

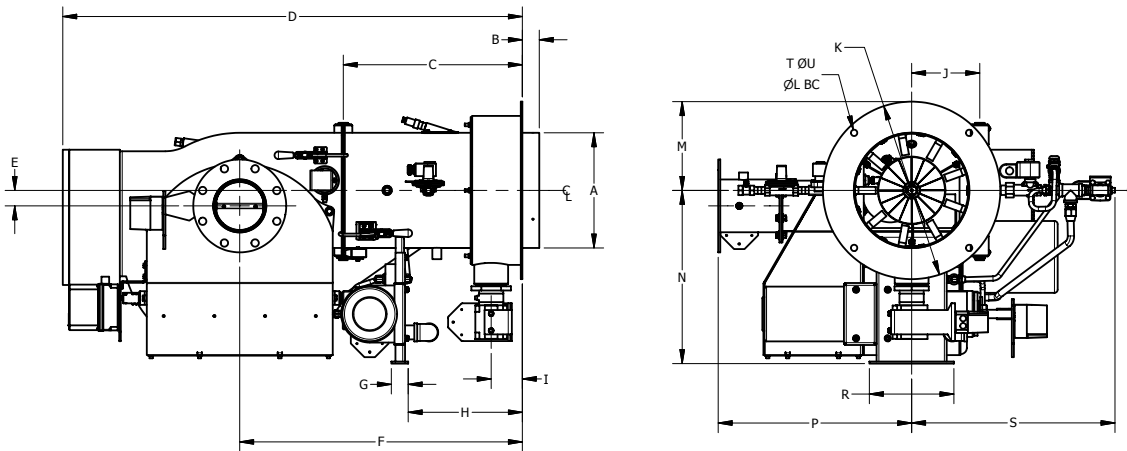

Burner Model	STANDARD CONFIGURATION - REAR MOUNTED PANEL																		
	A	B	C	D	E	F	G	H	I	J	K	L	M	N	P	R	S	T	U
Size 1	13 1/4	2	21 1/4	54 1/4	1 3/4	33 1/2	2	13 1/2	3 3/4	8	21	19 1/4	10 1/2	20 1/2	23	10	24	4	3/4
Size 2	16 1/4	2	29 1/2	69	4 3/8	44 3/8	3	18 1/5	4 1/8	10	24	22	12	27	25	20	28	8	1
Size 3	19 1/4	2	34 1/4	74	8 1/2	49 1/4	4	23 1/4	5 1/2	12 7/8	17	25	13 1/2	36	27 1/4	25	30	8	1
Size 4	Coming Soon!																		

Note: Final dimensions and ratings are subject to change based on application and options requested. Consult factory at time of quotation.



351 21st Street, Monroe, WI 53566-2798
608-325-3141 • ind-comb.com

Printed in the U.S.A.
Copyright © Industrial Combustion
IC-SA-1545
01/10